

---

This is a reproduction of a library book that was digitized by Google as part of an ongoing effort to preserve the information in books and make it universally accessible.

Google™ books

<https://books.google.com>







BODLEIAN LIBRARY  
OXFORD

COLLECTED BY  
**The United Daughters of the Confederacy**  
TO FORM  
**THE CONFEDERATE LIBRARY**

Domiciled in the Confederate Museum, Richmond, Virginia, U. S. A.,  
and Placed by Them in

PLACE Bodleian Library

DATE 1921

In the fervent hope that the Truth may be more broadly  
disseminated--  
"and the Truth shall make you free"

23352 d. 113

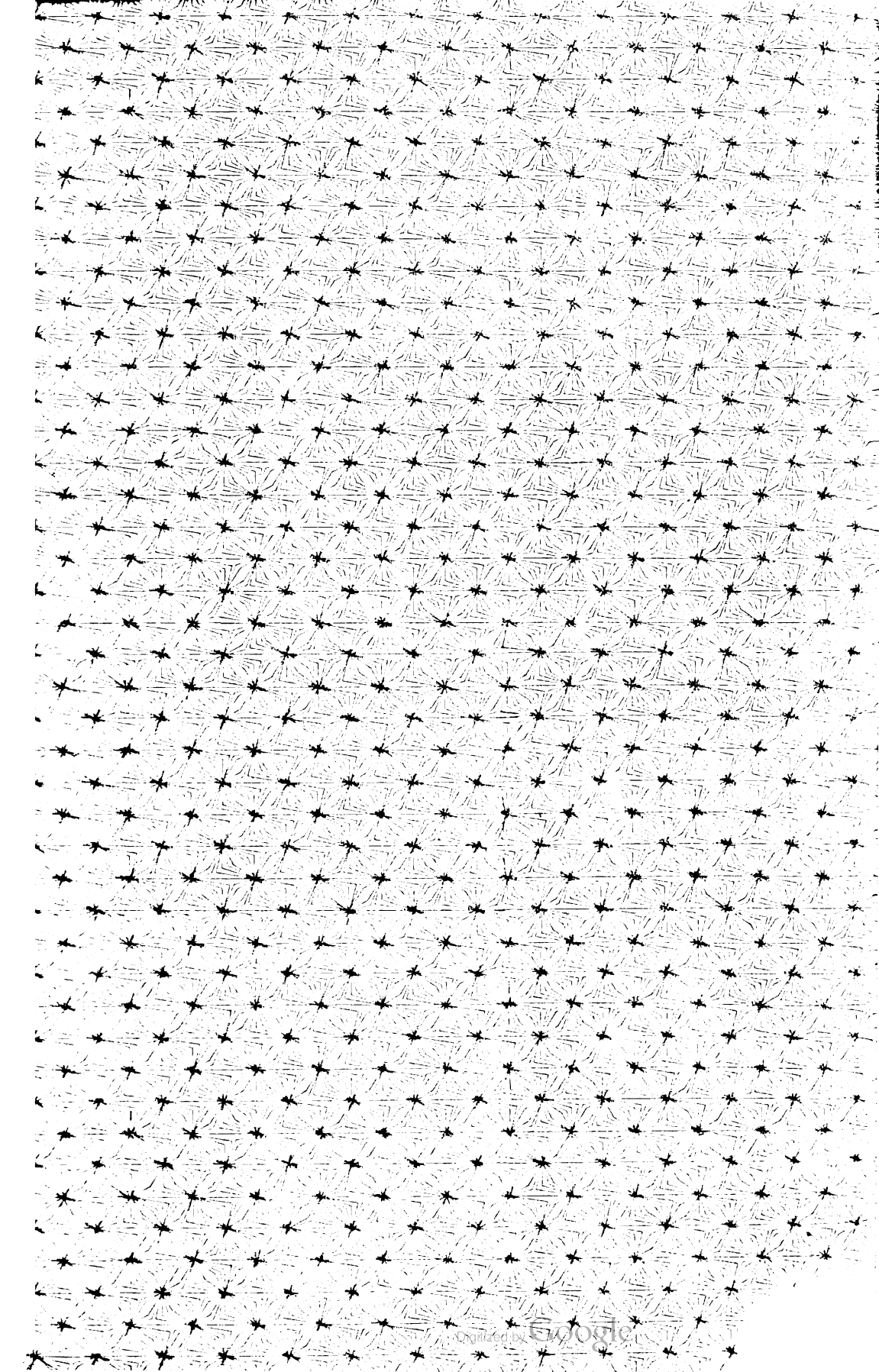

23152 1. 113

Presented to the Bodleian Library  
by

Mr. James Henry Parker  
President New York Chapter  
United Daughters of the Confederacy -

New York City  
March 1926.



THE DEFENSE  
OF  
CHARLESTON HARBOR,

INCLUDING  
FORT SUMTER AND THE ADJACENT ISLANDS.

---

1863—1865.

---

BY JOHN JOHNSON,  
FORMERLY MAJOR OF ENGINEERS IN THE SERVICE OF THE CONFEDERATE STATES

---

*WITH ORIGINAL PAPERS IN APPENDIX, FULL OFFICIAL  
REPORTS, MAPS, AND ILLUSTRATIONS.*

---

CHARLESTON, S. C. :  
WALKER, EVANS & COGSWELL CO., PUBLISHERS,  
3 AND 5 BROAD AND 117 EAST BAY STREETS.  
1890.



---

Copyrighted 1889,  
BY JOHN JOHNSON.

*(All Rights Reserved.)*

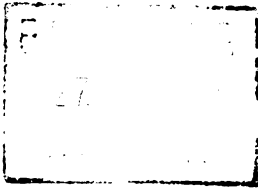

---

WESTCOTT & THOMSON,  
*Stereotypers and Electrotypers, Philada.*

## INTRODUCTION.

---

IN the war between the States, while the long defense of Charleston, South Carolina, was progressing under my command against a formidable attack by land and sea, and with then unprecedented appliances of warfare, it became evident to me that a well-prepared and authentic history of the operations was due as well to the brave forces of the South engaged as to the claims of military study and experience everywhere.

Accordingly, I issued the special order printed below, making provision for the need. It gives me pleasure now to find that such a history has, at length, been written by one of the officers originally appointed, whose work has been accepted and approved by two other members of the same board, as well as examined in part by myself. They unite with me in introducing and recommending it to the public.

G. T. BEAUREGARD.

*New Orleans, La., Jan. 7, 1890.*

HEAD-QUARTERS DEPARTMENT OF S. C., GA., AND FLORIDA, }  
CHARLESTON, S. C., April 19, 1864. }

\* \* \* \* \*

*Extract* } A Board to consist of five (5) members will assemble  
*Special Orders* } in Charleston, S. C., on the 20th day of April, 1864, or as  
No. 109, IV. } soon thereafter as practicable, for the purpose of compiling  
a military history of the siege of Charleston, S. C., to commence with  
the date of the naval attack on Fort Sumter, April 7, 1863.

The following are appointed members of the Board: Hon. Pierre Soulé, Vol. A. D. C., President; Major W. S. Basinger, Arty. P. A. C. S.;<sup>1</sup> Captain John Johnson, Engineers; Lieutenant John R. Key, Engineers, draughtsman. Captain H. W. Feilden, A. A. General, will, in addition to his present duties, act as Recorder for the Board, and if necessary may employ a competent clerk as an assistant.

<sup>1</sup> This designation of Major Basinger was erroneous. He was the commander of the Savannah Volunteer Guards, a volunteer corps of Savannah, Ga., which had been mustered into the service of the Confederate States "for the war," and was known in the service as the Eighteenth Georgia battalion. J. J.

Captain Johnson will continue to supervise the defense of Fort Sumter, but will leave an assistant in immediate charge of that work. He will be furnished by the chief engineer with a boat and crew, that he may visit the fort whenever necessary.

By command of General Beauregard.

H. WEMYSS FEILDEN,  
Capt., A. A. G.

---

The course of events immediately following the issue of the foregoing order of General Beauregard causing the dispersion of the officers composing the Board to distant parts of the Confederate States, and resulting in the fall and dissolution of the Confederacy, made impossible the execution of the order by the Board as a whole, and appeared to defeat the design of the general to preserve an authentic and detailed account, from our side, of the defense of Charleston, so honorable to the Confederate arms.

But that which the Board, as a whole, was thus prevented from doing has been done by Captain (afterward Major) Johnson, one of the Board, in his history of *The Defense of Charleston Harbor*, which is about to be given to the public. Nor is there any occasion for regret in the fact that Major Johnson has prepared this history without the aid of any of his colleagues. For it must be said that if the Board, as a whole, had had opportunity to attempt the duty assigned them, the laboring oar would inevitably have fallen to him. Passing by his other eminent qualifications for the task—any comment upon which in this place would, I am sure, be displeasing to him—his intimate connection with the defense as an engineer officer, and his special charge at Fort Sumter, which became, almost from the first, the main point of attack and defense, afforded him a knowledge and comprehension of details possessed by no other member of the Board. If, in addition to these considerations, it is borne in mind that his residence in Charleston since the war has tended to keep fresh in his mind familiarity with localities, and has afforded him access to many original sources of information, the inference is easy that aid from his colleagues would have been a hindrance to him rather than a help.

I have had the privilege of a hasty glance through Major Johnson's manuscript, and if approval from me is worth anything, I confidently commend his work as in the highest degree interesting, not only to those who took part in the scenes he describes and to all adherents of the Confederacy, but to all students of the military art.

WM. S. BASINGER,  
*Formerly Major Comdg. Sav. Vol. Guards, 18th Ga. Battalion.*  
DARLONEGA, GA., )  
Jan. 22, 1890. }

Though five-and-twenty years have elapsed since the close of the operations around the city of Charleston, the lessons to be derived from their study are as important as ever. We find a large commercial city, at the commencement of a great war defended by nearly obsolete works and with several unguarded approaches, rendered impregnable in a short time by the skill and genius of the general in command, supported by the indomitable valor, devotion, and tenacity of its defenders, and by the unflinching spirit of all ages and both sexes in the community. . . . I am glad to think that it has fallen to the lot of an active participator, and one of my comrades in the war of the Confederacy, to be the historian of those stirring events.

H. W. FEILDEN,

*Colonel and Chief Paymaster (retired list), H. B. M. Army.*

West House,  
Walls, Norfolk, England, }  
Jan. 4, 1890.



## PREFACE.

---

THE military operations by land and water before Charleston, South Carolina, especially from the spring of 1863 to the close of the Civil War in 1865, engaged the attention of the world to a more than ordinary degree. They were characterized by an attack involving two novel elements in warfare—viz. the use of armored vessels and of breaching rifles—and by a defense peculiar in respect of harbor obstruction with torpedo devices, active and passive. But the defense was also conducted with other and older elements of warfare, such as historians never tire of recording—viz. prolonged resistance and large measure of success. A contemporary writer in the French *Journal of Military Science* testified as follows: “Prodigies of talent, audacity, intrepidity, and perseverance are exhibited in the attack, as in the defense of this city, which will assign to the siege of Charleston an exceptional place in military annals.” The most recent military opinion upon these operations from an eminent foreign source is equally favorable to their great importance. Viscount Wolseley, adjutant-general of the British army, in reviewing one of the latest collections of historical papers covering the whole period, writes as follows: “Were I bound to select out of all four volumes the set of papers which appears of most importance at the present moment, not only from an American but also from a European point of view, I should certainly name those which describe the operations at Charleston.” (*North American Review*, November, 1889.) And if further evidence were wanted, Mr. Welles, Secretary of the U. S. Navy, pays the Charleston of Confederate times the highest tribute when in his annual report for 1865 he speaks of it as

having been the "most invulnerable and best-protected city on the coast, whose defenses had cost immense treasure and labor."

Fort Sumter was for a long time the citadel of Charleston harbor, and, having for its advanced work Battery Wagner on Morris Island, was the special object of attack. The fort, after being silenced and demolished, was transformed and re-armed under fire; it was then held for twelve months longer, until the whole coast of South Carolina was abandoned near the end of the war. It was never surrendered. The battery after a siege of fifty-eight days was successfully evacuated, and fell into the hands of the enemy. An English military critic in *St. Paul's Magazine* rates the defense of Fort Sumter as "eclipsing such famous passages of history as Sale's defense of Jellalabad against the Afghans or Havelock's obdurate tenure of the residency at Lucknow." And one of the most competent military authorities in America claims that it is but history "to say that the defense of Fort Sumter and that of Wagner are feats of war unsurpassed in ancient or modern times."

It was my privilege, as engineer-in-charge, to share with the officers and men of the garrison of Fort Sumter for fifteen of its most eventful months the arduous service of the post. And I may well feel it to be now my duty to record the story of their gallantry and endurance under the watchful eyes and skilful direction of superiors in command of the military district and department. This duty, once actually laid upon me, in conjunction with others, by a special order from General Beauregard, I have endeavored to perform to the best of my ability: certainly, both time and labor have been bestowed upon this work, and where defects are found it will not be because they have not been carefully searched for by the author himself. The constant aim has been to write a history which will be deemed worthy of its subject, without either falling into the dryness of the chronicler or lavishing on persons and things the superlatives of the war-correspondent.

Having preserved all my private notes, sketches, and diary, together with the engineer's official journal from July 20 to September 2, 1863, and my reports made almost daily to the chief engineer, and having also been aided by the authoritative

materials for history printed since the war, I have had the satisfaction of writing what is as nearly an official narrative in point of accuracy and fulness of particulars as could be desired. The published authorities which have been collected for this history are here enumerated :

*Armored Vessels* (Official Reports and Correspondence), being Exec. Doc. No. 69, Washington, 1864.

Reports published by Confederate Congress, Richmond, 1864.

Report and Documents, Major-General Q. A. Gillmore, New York, 1865.

Supplementary Papers (Gillmore), New York, 1868.

Reports of U. S. Navy Department for 1862, '63, '64, '65.  
Charleston City papers for the same years.

*Rebellion Record* (Putnam), 1865.

*Siege of Savannah*, Col. C. C. Jones, 1874.

*Southern Historical Society Papers*, Richmond, 1876.

*Afloat and Ashore* (Cowley), Lowell, 1879.

*Annals of the War* (Times Publishing Company), Philadelphia, 1879.

*Memoir of Rear-Admiral Dahlgren* (with *Diary*), Boston, 1882.

*Military Operations of Gen. Beauregard* (Roman), New York, 1884.

*Official War Records*, Series 1, vols. i., vi., xiv., xxviii., Washington, D. C.

*Charleston Year-Books*, 1883, '84, '85.

*History of the 104th Pennsylvania Regiment*, W. W. H. Davis, 1866.

The post-books of Colonel Rhett, commanding Fort Sumter, were used in writing up my journal of the first bombardment in August, 1863, but they have since been lost. The post-books of Major Elliott, who next succeeded to the command, are in good preservation and have been used by me. The post-books of Captains Mitchel and Huguenin, last in command of the fort, are believed to have been lost, but many of their despatches have been found in Washington, and Captain Huguenin has kindly contributed to the Appendix an original journal of the last severe days and nights of Battery Wagner, also a memoir, at request, for my guidance in narrating the closing events of the



having been the "most invulnerable and best-protected city on the coast, whose defenses had cost immense treasure and labor."

Fort Sumter was for a long time the citadel of Charleston harbor, and, having for its advanced work Battery Wagner on Morris Island, was the special object of attack. The fort, after being silenced and demolished, was transformed and re-armed under fire; it was then held for twelve months longer, until the whole coast of South Carolina was abandoned near the end of the war. It was never surrendered. The battery after a siege of fifty-eight days was successfully evacuated, and fell into the hands of the enemy. An English military critic in *St. Paul's Magazine* rates the defense of Fort Sumter as "eclipsing such famous passages of history as Sale's defense of Jellalabad against the Afghans or Havelock's obdurate tenure of the residency at Lucknow." And one of the most competent military authorities in America claims that it is but history "to say that the defense of Fort Sumter and that of Wagner are feats of war unsurpassed in ancient or modern times."

It was my privilege, as engineer-in-charge, to share with the officers and men of the garrison of Fort Sumter for fifteen of its most eventful months the arduous service of the post. And I may well feel it to be now my duty to record the story of their gallantry and endurance under the watchful eyes and skilful direction of superiors in command of the military district and department. This duty, once actually laid upon me, in conjunction with others, by a special order from General Beauregard, I have endeavored to perform to the best of my ability: certainly, both time and labor have been bestowed upon this work, and where defects are found it will not be because they have not been carefully searched for by the author himself. The constant aim has been to write a history which will be deemed worthy of its subject, without either falling into the dryness of the chronicler or lavishing on persons and things the superlatives of the war-correspondent.

Having preserved all my private notes, sketches, and diary, together with the engineer's official journal, from July 20 to September 2, 1863, and my reports made from time to time to the chief engineer, and having

... ..  
... ..  
... ..  
... ..  
... ..

... ..  
... ..  
... ..

**Year 1863**

... ..  
... ..

**Characteristics of the War**

*Evolution of the Army*  
*Steps of Strategy*  
*Southern Strategy*  
*Abolition and Emancipation*  
*Assault of the War*

**1879**

*Memorandum of the Secretary of War*  
*Military Operations*

**1884**

*Official War Lessons*

76

ington, D. C.

*Charleston Fort-June 1862*

AT-

*History of the Fort Sumter*

99

**1866**

*The post-war of the War*

PERIOD 115

OND PERIOD 133

CKED—

145

165

evacuation of Fort Sumter and Charleston harbor. Through the courtesy of officers in charge of the War-Records Office at Washington, copies were obtained from the unpublished Union reports of operations on Morris Island rendered by Brigadier-Generals T. Seymour and G. C. Strong (1863), and by Major-General J. G. Foster, commanding the Department of the South 1864-65. My thanks are due also to General Beauregard, Hon. W. A. Courtenay, ex-mayor of Charleston, Mr. J. Vaughan Merrick, naval constructor, of Philadelphia, to the "Century Company," and to many others for correspondence and assistance.

J. J.

CHARLESTON, S. C., December 1, 1889.

# CONTENTS.

---

	PAGE
CHAPTER I.	
PRELIMINARY FACTS AND EVENTS . . . . .	15
CHAPTER II.	
THE REPULSE OF THE IRON-CLAD SQUADRON . . . . .	40
CHAPTER III.	
THE RECOVERY OF THE GUNS OF THE KEOKUK . . . . .	62
CHAPTER IV.	
DESCENT OF THE UNION ARMY ON MORRIS ISLAND—FIRST AS- SAULT OF BATTERY WAGNER . . . . .	76
CHAPTER V.	
SECOND ASSAULT OF BATTERY WAGNER—FORT SUMTER THREAT- ENED . . . . .	99
CHAPTER VI.	
FIRST GREAT BOMBARDMENT OF FORT SUMTER—FIRST PERIOD	115
CHAPTER VII.	
FIRST GREAT BOMBARDMENT OF FORT SUMTER—SECOND PERIOD	133
CHAPTER VIII.	
MORRIS ISLAND EVACUATED—FORT MOULTRIE ATTACKED— FORT SUMTER ASSAULTED . . . . .	145
CHAPTER IX.	
THE SECOND GREAT BOMBARDMENT OF FORT SUMTER . . . . .	165

CONTENTS.

CHAPTER X.	
EXPLOSION OF MAGAZINE AND FIRE IN FORT SUMTER . . . . .	PAGE 186
CHAPTER XI.	
FORT JOHNSON ATTACKED—FORT SUMTER'S THIRD GREAT BOMBARDMENT . . . . .	208
CHAPTER XII.	
END OF THIRD GREAT BOMBARDMENT—EVACUATION OF SAVANNAH . . . . .	229
CHAPTER XIII.	
EVACUATION OF CHARLESTON HARBOR . . . . .	244
CHAPTER XIV.	
RÉSUMÉ AND CONCLUSION. . . . .	260

---

APPENDIX.

APPENDIX A.	
CALENDAR OF EVENTS, 1861-65 . . . . .	i
APPENDIX B.	
THE STEAM-FRIGATE NEW IRONSIDES . . . . .	xxi
APPENDIX C.	
NOTES OF IRON-CLAD WARFARE . . . . .	xxxvi
APPENDIX D.	
MEMOIR OF COLONEL (BRIGADIER-GENERAL) HARRIS, CHIEF ENGINEER . . . . .	xlii
APPENDIX E.	
STRATEGIC VALUE OF MORRIS ISLAND . . . . .	xlv
APPENDIX F.	
REPORTS (UNION AND CONFEDERATE), CORRESPONDENCE, DESPATCHES, JOURNALS, ETC. ETC. . . . .	1

## ILLUSTRATIONS.

---

	PAGE
PORTRAIT OF GENERAL BEAUREGARD . . . . .	17
PLANS AND SECTIONS OF FORT SUMTER (1862) . . . . .	19
MAP OF COAST OF SOUTH CAROLINA . . . . .	24
PLAN OF FORT LAMAR (SECESSIONVILLE) . . . . .	27
PLAN, ELEVATION, AND SECTION OF CONFEDERATE IRON-CLAD RAM .	33,34
PORTRAIT OF REAR-ADMIRAL S. F. DUPONT . . . . .	40
IRON-CLAD FRIGATE NEW IRONSIDES . . . . .	42
THE MONITOR PASSAIC . . . . .	47
TRANSVERSE SECTION OF TURRET AND PILOT-HOUSE . . . . .	48
PORTRAIT OF COLONEL A. RHETT . . . . .	49
SHOT-MARKS ON TWO FACES OF FORT SUMTER . . . . .	57
PORTRAIT OF BRIGADIER-GENERAL B. S. RIPLEY . . . . .	64
PLANS OF BATTERY (FORT) WAGNER . . . . .	89
PORTRAIT OF BRIGADIER- (MAJOR-) GENERAL Q. A. GILLMORE . . . .	96
PORTRAIT OF COLONEL D. B. HARRIS, CHIEF ENGINEER . . . . .	105
PENETRATION OF BREACHING RIFLE-SHELL (FORT SUMTER) . . . . .	117
PENETRATION OF A FUZE-PLUG AT FORT SUMTER . . . . .	126
PORTRAIT OF MAJOR (BRIGADIER-GENERAL) S. ELLIOTT . . . . .	156
COMPREHENSIVE VIEW OF INTERIOR OF FORT SUMTER, SEPT., 1863. .	166
PORTRAIT OF CAPTAIN F. H. HARLESTON . . . . .	178
FORT SUMTER: INTERIOR OF EASTERN HALF OF GORGE . . . . .	181
FORT SUMTER: INTERIOR OF EASTERN ANGLE AND SEA-FACE . . . .	183
FORT SUMTER'S FLAG (JAN. 29, 1864) . . . . .	186
FORT SUMTER: VIEW OF INTERIOR, DECEMBER, 1863 . . . . .	188

	PAGE
FORT SUMTER: EXTERIOR OF "THREE-GUN BATTERY" . . . . .	203
FORT SUMTER'S FLAG (FEB. 2, 1864) . . . . .	207
FORT SUMTER: REPLACING THE FLAG . . . . .	213
FORT JOHNSON, JAMES ISLAND . . . . .	217
FORT PRINGLE, JAMES ISLAND . . . . .	221
PORTRAIT OF CAPTAIN J. C. MITCHEL . . . . .	223
PORTRAIT OF CAPTAIN T. A. HUGUENIN . . . . .	230
FORT SUMTER: HEAD-QUARTERS CASEMATE . . . . .	241
"    "    INTERIOR OF THE GORGE . . . . .	253
"    "    EXTERIOR OF THE GORGE AND CITY FRONT . . . . .	255
"    "    INTERIOR OF SEA-FACE AND EASTERN ANGLE . . . . .	258

## AFTER APPENDIX.

PLATES I., II., III., IV., TORPEDOES (HARBOR).

PLATES V., VI., VII., OBSTRUCTIONS (HARBOR).

PLATE VIII. ELEVATIONS AND SECTIONS, TORPEDO-BOAT DAVID.

    "    IX. MAP OF MORRIS ISLAND.

    "    X. MAP OF CHARLESTON HARBOR.

    "    XI. FORTIFICATIONS SULLIVAN'S ISLAND.

    "    XII. PLANS OF FORT SUMTER (AS EVACUATED).

    "    XIII. SECTIONS OF FORT SUMTER (AS EVACUATED).

# THE DEFENSE OF CHARLESTON HARBOR.

## CHAPTER I.

### PRELIMINARY FACTS AND EVENTS.

#### 1861-1863.

A DESCRIPTION OF CHARLESTON HARBOR—ITS SURROUNDING ISLANDS AND SHORES—THE APPROACH BY STONO RIVER—DETAILED DESCRIPTION OF FORT SUMTER—ITS SITE, PLAN, AND CONSTRUCTION—OCCUPATION BY THE CONFEDERATES IN APRIL, 1861—REPAIRS AND IMPROVEMENTS—FORT MOULTRIE'S SITE, PLAN, AND CONSTRUCTION—OTHER WORKS ON SULLIVAN'S ISLAND—FORT RIPLEY—CASTLE PINCKNEY—FORT JOHNSON—FORTIFICATIONS OF JAMES ISLAND—MORRIS ISLAND AND ITS DEFENSES, BATTERY WAGNER AND BATTERY GREGG—CHIEF EVENTS IN MILITARY OPERATIONS BEFORE CHARLESTON, AND ON THE COAST ADJACENT TO IT, FROM DECEMBER, 1860, TO THE SPRING OF 1863—CAPTURE OF PORT ROYAL ENTRANCE AND BROAD RIVER BY THE UNION FLEET—REPULSE OF UNION FORCES AT SECESSIONVILLE—ACTIONS AT POCOTALIGO—CAPTURE OF UNION GUNBOAT ISAAC SMITH—ATTACK ON BLOCKADING SQUADRON OFF CHARLESTON BY TWO CONFEDERATE IRON-CLAD RAMS—HARBOR OBSTRUCTIONS, PILING, BOOMS, AND ROPE-NETTINGS—SPAR-TORPEDOES AND TORPEDO-RAM—THE BOILER-TORPEDO—CONFEDERATE IRON-CLAD RAMS—MILITARY STRENGTH AND ORGANIZATION OF THE DEPARTMENT AND DISTRICTS—THE FIRST MILITARY DISTRICT—GARRISONS AND ARMAMENTS OF FORTS AND BATTERIES APRIL 1, 1863.

It may be disappointing to some that this history does not cover the space of time between the outbreak of the war and the spring of the year 1863. It may be thought that the prominence of Charleston harbor, and particularly of Fort Sumter,



during that first period of the great struggle was too great to be lightly disregarded in a work of this kind. But the limitation has simply been a necessity with the author.

Moreover, the period in question has been already treated with fulness and ability by two military writers,<sup>1</sup> and to their works reference should be made for the history of that exciting time when, by the surrender of Major Robert Anderson in command of Fort Sumter, the control of Charleston harbor passed into the hands of the Confederates.

But in order to afford some information introductory to what follows in this volume, a few pages will be devoted to (1) a description of Charleston harbor, its surrounding islands, and the fortifications held by its defenders; (2) the chief military operations of 1861, '62, '63, which preceded the next chapter; and (3) the condition of the defenses immediately before the memorable action with the iron-clad squadron.

Charleston, the chief city and port of South Carolina, is built on a peninsula between the Cooper and the Ashley Rivers. They unite and widen into a capacious harbor lying mostly to the south-east of the city, bounded on the northern line by the main land and on the southern by James Island. This large island is accessible from the sea on the opposite side also, through Stono Inlet and River, a deep estuary dividing it from John's Island on the south, and admitting vessels to the rear of Charleston. Between Stono Inlet and the entrance of the harbor, a distance of twelve miles, there are two long, low, narrow, and sandy sea-islands—Folly Island and Morris Island—separated by a narrow inlet from each other, and by impracticable marshes, about two miles wide, from James Island, inside of them. Morris Island is nearly four miles long, its northern extremity, Cumming's Point, being the seaward limit of Charleston harbor on the south, as Sullivan's Island, near Fort Moultrie, is the limit on the north. These two points determine the entrance to the harbor, and are 2700 yards apart.

Sullivan's Island is of about the same length as Morris Island,

<sup>1</sup> *Military Operations of General Beauregard* (Roman), vol. i.; *Genesis of the Civil War*, by Major-General S. W. Crawford, U. S. A.





General G. T. BEAUREGARD, P. A. C. S.  
Commanding Department So. C., Georgia and Florida, 1862-64.  
From a Photograph.

Entered U. S. Mil. Acad. from Louisiana—Graduated 1838.—2nd Lieut. Corps  
of Engineers—Brevet Capt. and Maj. in Mexican War.  
Resigned from U. S. A., February, 1861.

having its western extremity farther inside the harbor than Cumming's Point, and its eastern extremity contiguous to Long Island. As on the other side of the harbor, impracticable marshes, of two miles in width, separate the sea-islands from the main land.

Fort Sumter, built upon a shoal and rising straight out of the water on its own island of artificial rock formation, is situated somewhat within the entrance to the harbor, and nearly equidistant from its opposite shores. Between the fort and the shores of Morris and James Islands there is only shallow water, unfit for navigation. The main channel is very deep between the fort and Sullivan's Island, takes a square turn to the south about a thousand yards east of Fort Sumter, continues straight along the shore of Morris Island, and is confined by the submerged bar on the ocean's side until near the southern end of the island, where it turns sharply to the east, crosses the bar with eighteen feet of water, and conducts at length into the ocean at a distance of eleven miles from the city of Charleston. The following notes of distance will be found useful :

From Fort Sumter to the East-Bay Battery of Charleston . . .	6000 yds. ( $3\frac{1}{2}$ m.)
From Fort Sumter to Fort Johnson, James Island . . . . .	2300 yds. ( $1\frac{1}{4}$ m.)
From Fort Sumter to Cumming's Point, Morris Island . . . .	1400 yds. ( $\frac{3}{4}$ m.)
From Fort Sumter to Battery Wagner . . . . .	2700 yds. ( $1\frac{1}{2}$ m.)
From Fort Sumter to Fort Moultrie, Sullivan's Island . . . .	1800 yds. (1 m.)

Fort Sumter, so named after General Thomas Sumter, one of South Carolina's partisan officers in the War of Independence, was begun by the United States Government in 1829, and was nearly completed when occupied by Major Anderson in December, 1860. Ten years appear to have been spent in raising its foundations above water. It was planned for a closed work of masonry, having five faces, with truncated angles, two tiers of guns in casemate and one in barbette. Looked at with a bird's-eye view, its symmetrical ground-plan would remind one of the gable-end of a plain house. The main salient of the bastion pointed northward; the two faces adjacent were each about 200 feet in length; the two flanks, east and west, were also about 200 feet; and the closed gorge, fortified only in barbette, was 350

feet long. The area of the site, on exterior lines, was about two acres and a half: that of the interior or parade of the fort was an acre and a quarter. The walls rose perpendicularly on all five sides to a uniform height forty feet above high water, but they varied in material and in thickness. The best Carolina gray brick laid with mortar and cement, also a concrete of pounded oyster-shells and cement, and another composition known as *béton*, were the materials used in the several parts of the structure. The last mentioned was the hardest of all the materials, but it was used only for the embrasures: the brickwork was the very best of its kind and the next in power of resistance. The wall proper—that is to say, the scarp-wall—was five feet in thickness, but as it was backed by the arches and supporting piers of the casemates, “the walls” of Fort Sumter, to speak popularly, varied from five to ten feet in thickness. A sally-port on the gorge opened upon a stone quay and landing-pier. This quay, extending all along the gorge, was twenty feet in width, and proved to be of the utmost importance in the defense of the fort. At the water’s edge, on the other faces of the fort, the rock foundation rose with an easy slope, and terminated at the base of the perpendicular brick scarp-wall with a ledge or berme ten feet in level width. This footing was both narrower and lower, and so more exposed to the tide and swell of the harbor, than the corresponding structure on the gorge.

As soon as Fort Sumter was occupied by the Confederate forces after the bombardment of April 12–13, 1861, steps were taken, chiefly under the immediate direction of Lieutenant-Colonel (afterward Brigadier-General) R. S. Ripley, to restore and complete it, with little or no departure from the original plan. The large spaces left for embrasures on the upper casemates were filled in with fresh brick masonry, showing only a narrow loophole. But three of these casemates at the main salient were finished with embrasures and armed. A large traverse of concrete cased with brick was built at the eastern angle of the ramparts to protect the barbette guns of the right face from enfilade by ships. The magazines, at the eastern and western extremities of the gorge, were strengthened by an exterior work of stone masonry, buttressing or reinforcing the gorge-wall



at each locality to a height of about fifteen feet. But their great exposure to a fire in reverse from ships lying off the eastern angle of the fort was not then realized or anticipated. Near the eastern side of the sally-port was constructed of brick a *caponnière* mounting two casemate-howitzers for the defense of the quay and pier. A telegraphic connection with headquarters in the city was established by the way of James Island. An improvement devised by Lieutenant-Colonel J. A. Yates of the garrison enabled the men to traverse the guns with cranks and cog-wheels, so that their aim could be kept on a moving object and their fire delivered with the greatest accuracy and rapidity. The hot-shot furnaces were restored. The brick barracks for soldiers' quarters on the interior of the eastern and western casemates were rebuilt, but with reduced height. So, in part, were the officers' quarters on the gorge. The fort was also supplied with gas-works, a bakery, a forge, a fire-engine, a shoe-factory, and a machine for converting salt into fresh water: it had besides large cisterns for rain-water.

An account of the garrison and armament will be given at the close of this chapter.

Fort Moultrie, built in 1811 on Sullivan's Island, at the entrance to the harbor, near the site of the palmetto fort which repulsed the British fleet in 1776, is of irregular plan, constructed of brick, "filled in with sand, presenting a battery of three sides on the sea-front," with brick magazine and barracks. Upon being occupied by the Carolina troops after Major Anderson abandoned it for Fort Sumter, great changes were made in its appearance; the low scarp-wall was protected by a ditch and glacis, traverses and merlons were constructed, and the magazine was covered over with sand of sufficient thickness.

Other works on Sullivan's Island were built by the Confederates in 1862—viz. Battery Bee,<sup>1</sup> about a half mile to the

<sup>1</sup> "Battery Bee was constructed by an accomplished engineer, Captain George E. Walker, who was careful to build his works with especial reference to the effect of modern artillery."—(*Brigadier-General Ripley, Charleston Year-Book, 1885.*) It was named after Brigadier-General Bernard Elliott Bee, killed in Virginia.

west of Fort Moultrie; Battery Beauregard, the same distance to the east; and Battery Marshall,<sup>1</sup> at the eastern end of the island. These works were of great strength, made of sharp sand, well sodded, and furnished with excellent magazines and bombproof quarters.

Fort Ripley was a small work, built in 1862 on the middle ground or shoal between Castle Pinckney and Fort Johnson and two miles inside of Fort Sumter. Its plan was four-square, and its construction with ballasted cribwork of heavy timber; but it was deemed hardly shotproof.

Castle Pinckney, built of brick and rough-cast, in 1810, on a low, marshy island known as "Shute's Folly," was distant one mile from the city. It was a complete little casemated work of that period, but on so small a scale and so near to the city as to be of little value in the defense of the harbor. Its casemates were disarmed, its front wall was covered with an exterior slope of sand, well sodded, and its ramparts furnished with merlons and traverses.

Fort Johnson, on the harbor shore of James Island, occupied ground older than the site of Fort Moultrie, having been first built in 1704. Mortar-batteries, erected there in 1861, took part in the reduction of Fort Sumter. No fortification of consequence, however, was built there until the summer of 1863, but then, being continually enlarged and strengthened, it became in 1864-65 a strongly fortified camp, with a heavy battery on its harbor front.

Against an enemy's approach from Stono there were extensive but not very strong lines in the interior of James Island for siege or light artillery and for infantry troops; the right resting on the Stono River, near Wappoo Cut, at Fort Pemberton, a large well-built work, heavily armed; the left resting on the marshes of Folly River, at Secessionville, where Fort Lamar, a lighter work than "Pemberton," but very capable, as its record in 1862 proved, disputed any advance upon the island. The outposts of James Island in this direction were Cole's Island and Battery Island, two small strips of sandy soil connected with the southern extremity by causeways and

<sup>1</sup> So called in honor of Colonel J. Foster Marshall, killed in Virginia.



fortified with guns bearing on Stono Inlet and Stono River. But by order of Major-General J. C. Pemberton in the spring of 1862 these islands were abandoned or only used for picket-stations.

The fortifications of Morris Island, which had been built for the reduction of Fort Sumter in April, 1861, gave place to two works of great importance. These were Battery Gregg, on Cumming's Point, and Battery (or Fort) Wagner, about three-fourths of a mile farther south. The former, named after Brigadier-General Maxcy Gregg of South Carolina, killed at Fredericksburg, Va., was a work of strong relief and thick parapets, with magazine and bombproof, and places for three heavy guns to fire upon the channel and the island.

Battery Wagner, so called after Lieutenant-Colonel Thomas M. Wagner of the First regiment of South Carolina (regular) Artillery, who lost his life by the bursting of a gun at Fort Moultrie in July, 1862, was located at a narrow part of the island and extended across its full width. First ordered by Major-General Pemberton, it was planned by Captain Francis D. Lee of the Engineers, and ground was broken in the summer of 1862 under Assistant Engineer Langdon Cheves, who continued to superintend the work until completion. But the strengthening of it by the addition of a heavy flanking battery for four guns bearing on the channel, and by closing the gorge with a parapet for infantry fire, was ordered by General Beauregard soon after his taking command, and accomplished early in the next year. Its sea-face extended about 300 feet along the beach, and its total of land-faces nearly 800 feet across the island.

Ground was broken, by order of General Beauregard, for the construction of batteries on the southern end of Morris Island as early as the first week in March, 1863, but none were completed when, a month later, the iron-clad squadron attacked Fort Sumter.

The chief military and naval operations conducted by both sides on the coast of South Carolina, from the outbreak of the war to the spring of 1863, a space of two years, will now be

related very briefly. (For a full calendar of all the operations reference must be made to Appendix A.)

It seems hardly necessary to repeat the oft-told story of Major Robert Anderson's transfer of his two companies of United States artillery from Fort Moultrie to Fort Sumter on the evening of December 26, 1860.<sup>1</sup> Hostile preparations began in earnest from that date. But the first hostile guns were not fired until January 9, 1861, from Morris Island, when the transport-steamer *Star of the West*, conveying arms, supplies, and reinforcements (200 men) to the garrison, was forced to desist and go out again.

Three months later Fort Sumter was bombarded by the forts and batteries of Charleston harbor, April 12th-13th, and its garrison surrendered by Major Anderson, after a brave defense of thirty-three hours, to the Confederate forces under Brigadier-General G. T. Beauregard. Three gunboats, with a troopship sent to reinforce Major Anderson, remained idle spectators of the engagement. The garrison was allowed to salute its flag before leaving the fort, and, being conveyed by the Confederates, April 14th, to the fleet waiting outside the bar, sailed immediately for New York. The casualties in this action were remarkably few. But four had been slightly wounded among the Carolinians. In Fort Sumter four of the garrison were wounded, two severely and two slightly. By accident on the

<sup>1</sup> The author of the *Genesis of the Civil War* appears to have been impressed with wonder at the extraordinary absence of the guard-boat from her station between the forts on that particular night. He says: "Had the guard-boat been present at her usual hour and carried out her orders, it would have been impossible to accomplish" the transfer. These orders, he says rightly, were regularly transmitted each night by an aide-de-camp from the governor's head-quarters. The concurrent testimony of Captain Joseph Johnson, Jr., and Lieutenant Thomas S. Mills, commanding the guard (Charleston Riflemen), is that "the usual hour" was wholly uncertain, but was, at least, not earlier than eight, nor later than nine, o'clock. The garrison, acting intelligently upon its own observation of the guard-boat service, began its movement "shortly after dusk," and completed it before eight o'clock, as Major Anderson reports. The innocent carelessness of the Carolinians is amusing; the unaccountable amazement of the prudent and elusive garrison appears to be hardly less so. The guard-boat did not leave the city until the guns of Fort Sumter announced the transfer completed.

day after the surrender one man was killed and five men were wounded at the same post.

It was not until November of the same year that hostilities



MAP OF THE COAST BETWEEN CHARLESTON AND SAVANNAH.

were renewed on the sea-coast of South Carolina. Port Royal entrance to Broad River was a harbor where the navies of the world might ride at anchor. A Union fleet of seventeen vessels carrying 200 guns, under Flag-Officer S. F. DuPont, with 12,000 troops under Brigadier-General Thomas W. Sherman, was sent to occupy it and establish there a permanent naval station of the first grade. The Confederate defenses consisted of Forts Walker and Beauregard, the former (23 guns) on the southern, the latter (20 guns) on the northern, shore of the entrance, which was a little over two miles wide. A force under Brigadier-General T. F. Drayton was stationed for support on Hilton Head Island, and a weak flotilla under Commodore Tatnall was present and took part. On the morning of November 7th the fleet engaged both forts simultaneously, and after an action of four hours they were abandoned by the garrisons and captured. The Union loss was 31; the Confederate, 66. The hasty retreat of the Confederates was not interrupted, nor was any attempt made for a long time by the Union troops to cut the important communication of the Charleston and Savannah Railroad, within

day after the surrender one man was killed and five men were wounded at the same post.

It was not until November of the same year that hostilities

easy reach of the head of Broad River. The town of Beaufort was deserted, and with the neighboring country was given over to pillage; the lands were confiscated for taxes, and some have never been returned to their former owners.

In the following spring, May 29, an effort was made by a full regiment, with artillery, under command of Colonel B. C. Christ, to destroy the Charleston and Savannah Railroad near Pocotaligo. It was foiled by the Confederate force under Colonel W. S. Walker, who brought into action only some squadrons of dismounted cavalry, but drove back the enemy with loss. This became known as the first action at Pocotaligo. (See *Appendix A.*)

In consequence of the abandonment of Cole's Island, at Stono Inlet, through an unwise order of the Confederate commander, May 12, 1862, the Union forces under Major-General David Hunter were increased, and an attempt was made to push through James Island to Charleston itself with about 12,000 men. The Confederate force on James Island at this time was nearly 14,000 men, under Brigadier-General N. G. Evans. The extreme left of his long line was defended by Battery Lamar at Secessionville, an advanced earthwork armed with seven guns, and advantageously located on a tongue of land flanked by marshes.<sup>1</sup> A smaller work on the right, Battery Reid, was in supporting distance with two siege-guns. After several days of reconnoitring and skirmishing, Brigadier-General H. W. Benham, apparently disobeying Major-General Hunter's orders, attacked the works at Secessionville with two divisions and a brigade (7000 men) early on the morning of June 16, 1862. The Confederates, under Colonel T. G. Lamar, Second South Carolina Artillery, were nearly surprised and worsted at the onset, but, resisting bravely and being reinforced to about 750 men, they successfully repelled four charges of the enemy, inflicting on them a disastrous repulse and a reported official loss of 683 men, the Confederate loss being 204, of which 32 were in the defense of the right by Brigadier-General Hagood. In two weeks from this defeat the Union troops evacuated James Island.<sup>2</sup>

<sup>1</sup> The selection of the site has been generally accredited to Colonel L. M. Hatch, who also constructed it with the labor of his regiment of Rifles.

<sup>2</sup> The Confederates engaged at Secessionville were the Second South Carolina

The second action at Pocotaligo marked the operations of the fall (October 22d-23d) on the coast of South Carolina. It was in larger force than before, and with more determination, that Brigadier-General J. M. Brannan moved from Beaufort upon the line of the Charleston and Savannah Railroad. Landing at Mackay's Point, his column of 4500 men skirmished while advancing as far as the bridge at "Old" Pocotaligo. There the Confederates, under Brigadier-General W. S. Walker, with infantry, artillery, and cavalry, a total of scarcely 500 men, engaged the Union troops, and forced them back to their gunboats with a loss of 340 men, the Confederate loss being less than half that number. A portion of General Brannan's force succeeded in gaining the railroad near Coosawhatchie, but by the timely intervention and resistance of some cavalry under Colonel C. J. Coleock it was prevented from doing any great damage, and was driven back with the main command to its landing on Broad River. (See *Appendix A*; also *War Records*, vol. xiv.)

The next engagement was the capture of the Union gunboat Isaac Smith, Lieutenant-commanding F. S. Conover, carrying eleven guns. The scene of this brilliant affair was the Stono River, and the time January 30, 1863. A combination of infantry, with light and siege batteries,<sup>1</sup> some concealed on the John's Island side, others on the James Island side of the Stono River, all acting under command of Lieutenant-Colonel Joseph

Artillery, the Fourth Louisiana battalion, Charleston battalion, the Twenty-second South Carolina volunteers, details, and the Ninth South Carolina battalion. An important movement of the enemy on the right advance of the position was met and defeated by the First, the Twenty-fourth, and the Twenty-fifth South Carolina volunteers under Brigadier-General J. Hagood. (For a complete account of the action see a paper by General Hagood in the *Southern Historical Society Papers*, vol. xii.; see also *War Records*, vol. xiv.)

<sup>1</sup> The commands engaged were—Siege-train, 2 companies; Palmetto battalion, 1 company; First South Carolina (regular) Artillery, 2 companies; Lucas's battalion, 3 companies; Second regiment South Carolina Artillery, detachment; Twentieth South Carolina (volunteer) Infantry, 2 companies; Georgia battalion, detachment. (For a full and graphic account of the dispositions made and of the action see a narrative by William H. Chapman, first lieutenant Palmetto Guards Artillery, in the *News and Courier*, Charleston, S. C., October 12, 1885; see also U. S. naval reports and *War Records*.)

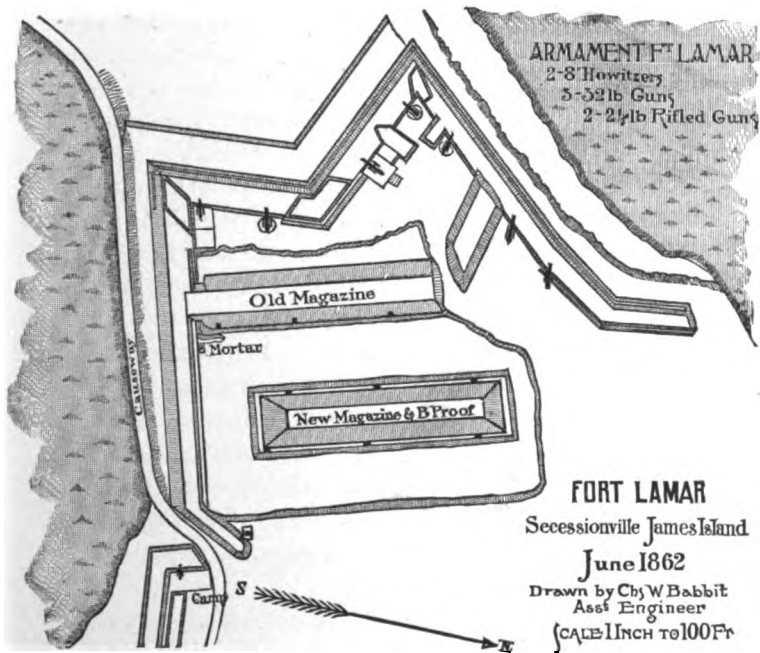

A. Yates of the First South Carolina (regular) Artillery, caught the boat completely by surprise, and before she could escape disabled her, taking all hands prisoners (11 officers and 108 men), among whom there were 24 casualties—9 killed and 15 wounded. The boat was soon brought through Wappoo Cut into the harbor, repaired, and put to use by the Confederate naval officers: she was called the *Stono*, and finally ran the blockade. The thanks of the Confederate Congress were voted to Lieutenant-Colonel Yates and his gallant comrades. Their loss was one man, mortally wounded.

It was early the next morning after the capture of the *Isaac Smith* that Flag-Officer D. N. Ingraham attacked the blockading squadron off Charleston with the iron-clad rams *Palmetto State* and *Chicora*. Two of the blockaders, the *Mercedita* and the *Keystone State*, were severely injured and surrendered, but were not taken possession of, and consequently they made their escape. The rams had no speed or sea-going qualities, and could not give chase farther than some miles seaward, but they succeeded in dispersing the squadron of about ten vessels, and returned within the harbor after being masters of the situation for nearly twelve hours. They suffered no injury themselves, and had no casualties. The *Palmetto State*, bearing the commodore's flag, was under Lieutenant-commanding John Rutledge, and received the surrender of the *Mercedita*, Captain H. S. Stellwagen. The *Chicora*, under Commander John R. Tucker, engaged the *Keystone State*, Commander W. E. LeRoy, and so disabled her as to cause the hauling down of her flag; but while a boat was making ready to receive her surrender the expected prize slipped away from the captors. The Union loss was severe, being a total of 47 casualties—27 killed and 20 wounded. It was contended by some of the Confederate authorities that the blockade of Charleston harbor was raised by this attack, but, being disputed, the point was never sustained. This naval action, which came near to being a great success, together with the capture of the *Isaac Smith* and the repulse of the enemy at Secessionville the year before, combined to inspire the defenders of Charleston very greatly, and encourage them to make preparation for the more serious work of the year which had just begun.

The condition of the defenses immediately around the city and within its harbor varied considerably from month to month throughout the long course of a trying experience. Repairs and improvements of forts and batteries, changes in their armament, progress in naval construction, experiments with new devices for obstructing channels, all gave active and constant employment to officers and men, mechanics and laborers. In nothing was this variableness more to be noticed than in regard to the obstructions placed in all the navigable approaches and thoroughfares.

A beginning was made in 1862 by driving pine timber piles in a double row across the Middle Ground and Castle Pinckney channel, on a line due north of Fort Johnson and between 600 and 700 yards in front of Fort Ripley. The piles extended in line over half a mile, leaving a space of three-fourths of a mile of deep water off Fort Johnson. The decay of these piles called for continual renewal, and the effect of gales would be to break off the weaker ones and leave serious gaps in the line. Though this obstruction belonged entirely to the inner harbor, and did not cross the ship-channel, it was maintained to the end of the war.

In the same year obstructions were placed in Stono River—first, of cribs with ballast off Battery Island, and in May of live-oak trunks and branches off Fort Pemberton.

It was in May also that steps were taken, under Major-General J. C. Pemberton, commanding, to construct a boom of heavy timber logs, weighted and coupled with iron, and to anchor it across the channel between Forts Moultrie and Sumter. The gales and the strong currents of the tideway, thirty to forty feet deep, proved too much for it; and this boom, prepared at great expense and under great difficulties, having been twice broken and nearly destroyed before the end of the year, was finally abandoned.<sup>1</sup> Use was made, however, of some of its sections to obstruct minor channels less exposed to wind and tide. A few sections were left in their original position, and were combined with another arrangement in 1863.

<sup>1</sup> It was losing its buoyancy also. The "zeal and indefatigable industry" of Dr. John R. Cheves, who devoted himself to its construction, were specially commended from department head-quarters.



This latter was the rope-obstruction, consisting at first of a continuous line of three cables "ratlined" together like the shrouds of a ship, the upper cable floated and bearing slack lines of rope to entangle wheels and propellers, the lower cable anchored to the bottom, bearing also streaming ropes of about fifteen feet in length, for the same purpose. Then, being broken, it was placed in sections; and in this state, with its formidable array of beer-barrel floats, *and an opening left next Fort Sumter three hundred yards wide*, this rope-obstruction, taken to be a network of torpedoes, was to play an important part in the attack by the iron-clad squadron.

Later in the year the lower cables were discarded, and a single cable, floated in two lines and anchored in sections at one end only, bore all the streaming ropes designed to foul propellers. This became the modified and settled plan of the obstructions to the close of the defense. The plates at the end of the volume show these rope-obstructions, booms, and torpedoes.

The application of torpedoes for defense of harbors and waterways must be dated from the first years of the war, when an experiment was made by Confederates upon the Union squadron in the Potomac River, July 7, 1861.<sup>1</sup> The impulse given was at once followed up by the experiments and devices of the "Torpedo Bureau," established in Richmond, Virginia, October, 1862, under the charge of Brigadier-General G. J. Rains, and the "Naval Submarine Battery Service" was organized under command of Captain M. F. Maury, who relinquished it to Lieutenant Hunter Davidson, both of the Confederate navy.<sup>2</sup>

General Beauregard, in command at Charleston, was among the first to appreciate this new engine of war; and when in March, 1863, his attention was called by Captain F. D. Lee to the complete success of a spar-torpedo which he had invented, orders were immediately given to extend the use of this device throughout the military department of South Carolina, Georgia,

<sup>1</sup> *History of the Confederate Navy* (Scharf), chap. xxiii., Torpedo Service, New York, 1887.

<sup>2</sup> Full particulars of the real origin of torpedo warfare cannot be given here, but they are contained in *Southern Historical Society Papers*, vols. ii., iii., iv.; also in *Annals of the War*, Philadelphia, 1879, where General Beauregard gives a detailed account of their use in Charleston harbor.

and Florida. Captain Lee, a native of Charleston, was an officer of Engineers who had served with distinction from the first period of the war, and after planning and constructing many fortifications on the coast, particularly Battery Wagner in the earlier stages, devoted himself to this interesting study of explosives. The spar-torpedo was simply a cylinder of copper or other thin metal or wood, made water-tight, filled with fifty to one hundred pounds of powder, capped with several highly sensitive percussion fuses on its conical or rounded end, the whole fixed firmly on a spar of wood or iron from twenty-five to thirty feet long, and pushed through the water some feet below the surface against its object.

Its merits were promptly recognized by Lieutenant W. T. Glassell of the Confederate Navy, although some of his superiors had a great contempt for such "new-fangled notions." With the co-operation of Captain Lee and the pecuniary assistance of Mr. George A. Trenholm of Charleston, Glassell fitted out a flotilla of twelve small boats armed in this way for the purpose of attacking the Union fleet. How he afterward attacked the steam-frigate *New Ironsides* is well known, and can be found described fully in *Appendix B*. The objection to using the spar-torpedo, first raised by the navy, was overruled, and in a short time every Confederate iron-clad ram was mounted with one, carried in or out of the water at the end of a light iron spar thirty feet long.

Captain Lee procured the assistance of the State of South Carolina toward the purchase and preparation of a strongly-built boat to carry a spar-torpedo, to be made shot-proof with armor, and also very swift, so as to attack with impunity the largest vessels outside the harbor. The scheme was earnestly but vainly pressed by General Beauregard on both the Army and Navy Departments at Richmond, and after expending \$50,000, the State's appropriation, without completing his boat, Captain Lee had the mortification of seeing it laid up, a useless hulk, to the end of the war. Two other and much lighter boats were subsequently used with success—the *David* and the *Fish Boat*—but this torpedo-ram, designed by Lee for use in Charleston harbor and outside the bar, was the real precursor of the boats now universally adopted in the navies of the world.

Fixed torpedoes were placed in the waters around Charleston for the first time in March, 1863,<sup>1</sup> by order of General Beauregard, and the locality chosen was in Ashley River, below the railroad bridge at Spring street. These were frame torpedoes, and were put down also in Hog Island Channel and Castle Pinckney or Folly Channel. But there is no evidence of any having been placed between Fort Sumter and Sullivan's Island before July 10, 1863, three months after the attack by the iron-clad squadron.<sup>2</sup>

The large boiler-torpedo (electric) sunk in the ship channel about half a mile east by north of Battery Wagner is fully described, with sketches, in a report made May 25, 1863, to General Beauregard by Charles G. DeLisle, assistant engineer.<sup>3</sup> He reports that "a few days before the attack on the forts a boiler eighteen feet long, three feet in diameter, containing 3000 pounds of powder, was laid by General Ripley's order in the main ship channel, about one mile off Fort Sumter and half a mile opposite Fort Wagner." The part which this large torpedo did *not* take in the attack of the iron-clad squadron, April 7, is described in Chapter II. and Appendix B.

DeLisle says, further, that on April 5th (two days before the fight) General Ripley ordered another boiler to be sunk in the channel between Sumter and Moultrie, but, not being made ready in time for that locality, it was sunk hastily during the afternoon of the 7th opposite White Point Battery in a place called "Poor Man's Hole," and was never recovered.

Two iron-clad steam-rams, built on the general plan of the Merrimac (Virginia) with slanting casemate sides, were built in Charleston, and took their places for the defense of the harbor in the end of the year 1862.

The first launched was the Palmetto State, with iron plating four inches thick, "a battery of one 80-pounder rifle gun forward, a 60-pounder rifle aft, and one VIII-inch shell-gun on each broadside." The next was the Chicora, armed with six guns,

<sup>1</sup> *War Records*, vol. xiv. page 835. Captain M. M. Gray testified that he laid them as early as February. (Report Secretary U. S. Navy, 1865.)

<sup>2</sup> Captain Gray, Report Secretary of Navy, 1865, page 285.

<sup>3</sup> *War Records*, vol. xiv. pages 948-952.

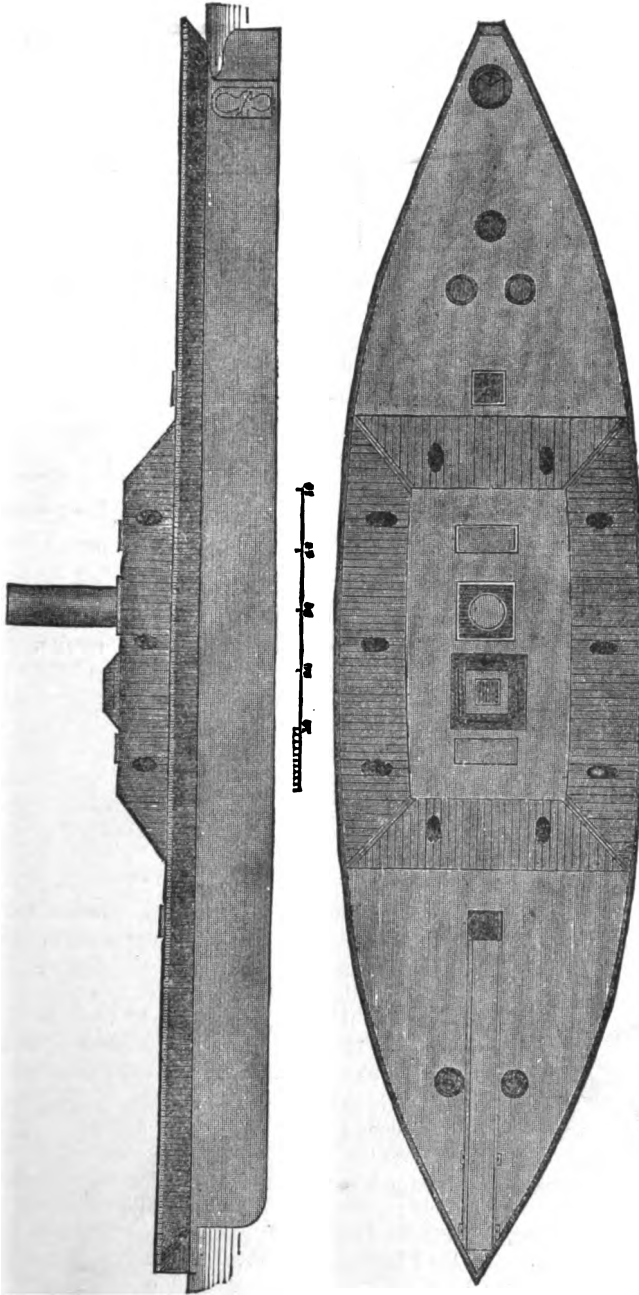

PLAN AND ELEVATION OF CONFEDERATE IRON-CLAD RAM COLUMBIA, CHARLESTON HARBOR.

two IX-inch smoothbore and four 60-pounder rifles. These boats were well built, but their steam-power was insufficient for

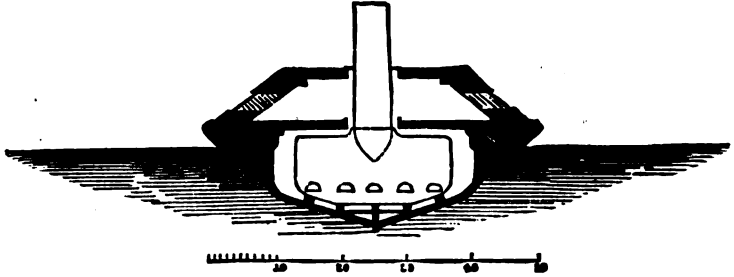

TRANSVERSE SECTION OF CONFEDERATE IRON-CLAD RAM, CHARLESTON HARBOR.

the speed required of rams, and their engines called for constant repairing. Their crews numbered from 120 to 150 men.<sup>1</sup>

<sup>1</sup> A third and stronger ram, the *Charleston*, was completed early in 1864. A fourth, the *Columbia*, with six inches of plating, was completed early in 1865, but, being disabled by an accident, she was never in service. The wooden gunboat prize, *Isaac Smith*, was "a very swift steamer of 450 tons," mounting one rifled gun and eight VIII-inch smoothbores. Under the new name of *Stono* and the command of Captain H. J. Hartstene she was a valuable colleague of the rams until the night of June 5, 1863, when in trying to run the blockade she was wrecked off Fort Moultrie. The *Juno*, Lieutenant Philip Porcher commanding, distinguished for the capture of a Union launch, was eventually lost at sea running the blockade with cotton for Nassau in the fall of 1863, nearly all on board perishing.

The officers of the *Palmetto State* were—Flag-Officer, D. N. Ingraham, commanding squadron; Lieutenant-Commander, John Rutledge; Lieutenants, W. H. Parker, Philip Porcher, G. S. Shyrock, R. J. Bowen; Master, F. T. Chew; Surgeon, A. M. Lynah; Chief Engineer, M. P. Jordan; Midshipmen, C. F. Sevier, W. P. Hamilton, C. Cary; Pilots, G. D. Gladden, A. Johnson.

The officers of the *Chicora* were—Captain, J. R. Tucker; Lieutenants, G. H. Bier, William T. Glassell, W. H. Wall; Master, A. M. Mason; Acting Master, J. A. Payne; Passed Midshipman, J. P. Claybrooke; Midshipmen, R. H. Bacot, Palmer Saunders, Roger Pinckney; Surgeon, W. M. Turner; Engineer, H. Clarke; Pilots, Thomas Payne and James Aldert.

In the early part of 1864, when the *Charleston* was commissioned, Commodore Tucker transferred his flag to her from the *Chicora*. She was commanded by Commander Isaac N. Brown; Commander Thomas T. Hunter was assigned to the *Chicora*, and Commander James H. Rochelle to the *Palmetto State*. (For all of this information I have been indebted to Scharf's *History of the Confederate Navy*.—J. J.)

It remains only that the military strength of Charleston harbor and vicinity in men and arms, as it was about April 1, 1863, should be now described.

The Department of South Carolina, Georgia, and Florida had its head-quarters at Charleston, where since September 24, 1862, General G. T. Beauregard had been in command. His staff was constituted as follows: Brigadier-General Thomas Jordan, Chief of Staff; Lieutenant-Colonel J. F. Lay, Adjutant and Inspector-General; Lieutenant-Colonel Alfred Roman, Adjutant and Inspector-General; Lieutenant-Colonel J. R. Waddy, Chief of Ordnance; Major John T. O'Brien, A. A. G.; Captain H. Wemyss Feikden, A. A. G.; Captain Clifton H. Smith, A. A. G.; Captain John M. Otey, A. A. G.; Captain E. Pliny Bryan, A. A. G.

Engineer Department: Major David B. Harris, Chief Engineer Department; Major William H. Echols, Chief Engineer of South Carolina; Colonel A. J. Gonzales, Chief of Artillery; Major Hutson Lee, Chief Quartermaster; Surgeon R. L. Brodie, Chief Medical Director; Major H. C. Guerin, Chief of Subsistence; Major Henry Bryan, Adjutant and Inspector-General.

The coast of South Carolina was divided into four military districts, as follows:

1st. The First Military District, Brigadier-General R. S. Ripley commanding, embraced the works for the defense of the harbor and approaches to the city of Charleston, limited on the east by the South Santee River and on the west by the Stono and Rantowle's Creek.

2d. The Second Military District, Brigadier-General Johnson Hagood commanding, extended from the western limit of the First District to the Ashepoo River.

3d. The Third Military District, Brigadier-General W. S. Walker commanding, was limited on the east by the Second Military District and on the west by the Savannah River.

4th. The Fourth Military District, Brigadier-General James H. Trapier commanding, was bounded on the south-west by the South Santee River and on the north-east by the boundary-line

between the States of North and South Carolina.—(*War Records*, vol. xiv.)

The organization of troops in the First Military District was as follows (March 13, 1863):

Brigadier-General R. S. RIPLEY commanding.

*James Island and St. Andrew's Parish.*

Brigadier-General S. R. GIST commanding.

8th Georgia Battalion, Major B. F. Hunt.

25th South Carolina, Colonel Charles H. Simonton.

3d South Carolina Cavalry, Company K, Captain T. Cordes.

Ferguson's (South Carolina) Cavalry, Company G, Captain B. W. McTureous.

2d South Carolina Artillery, Lieutenant-Colonel A. D. Frederick.

Lucas's (South Carolina) Battalion of Artillery, Major J. J. Lucas.

Palmetto (South Carolina) Battalion of Artillery, Lieutenant-Colonel E. B. White.

*Brigadier-General T. L. Clingman's Brigade.*

8th North Carolina, Colonel H. M. Shaw.

31st North Carolina, Colonel John V. Jordan.

51st North Carolina, Colonel Hector McKethan.

61st North Carolina, Colonel James D. Radcliffe.

German Artillery, Company B, Captain F. Melchers.

*Sullivan's Island and Christ Church Parish.*

Brigadier-General JAMES H. TRAPIER, commanding, having been temporarily withdrawn from command of the Fourth Military District.

1st South Carolina Infantry (regulars), Colonel William Butler.

20th South Carolina Infantry, Colonel L. M. Keitt.

Ferguson's (South Carolina) Cavalry, Company E, Captain L. A. Whilden.

Rutledge (South Carolina) Cavalry, Company D, Captain Thomas Pinckney.  
 1st South Carolina Artillery (regulars), Companies I and K, Captain J. A. Sitgreaves.  
 Ferguson's Light Battery, Captain Thomas B. Ferguson.  
 German (South Carolina) Artillery, Company A, Captain D. Werner.  
 Santee (South Carolina) Artillery, Captain Christopher Gaillard.

*Morris Island.*

21st South Carolina, Colonel Robert F. Graham.  
 Gist Guards, Captain C. E. Chichester.  
 Mathewes Artillery, Captain J. R. Mathewes.

*City of Charleston.*

46th Georgia, Colonel P. H. Colquitt.  
 Charleston Battalion, Lieutenant-Colonel P. C. Gaillard.  
 21st Battalion Georgia Cavalry, Major W. P. White.  
 South Carolina Siege-Train, Major Charles Alston, Jr.

*Castle Pinckney and Fort Ripley.*

1st South Carolina Artillery (regular), Company H, Captain H. S. Farley.

*Fort Sumter.*

1st South Carolina Artillery (regular), Companies B, C, D, E, F, G, I, Colonel Alfred Rhett.

According to the returns of troops made April 7, 1863,<sup>1</sup> the following will exhibit the totals of "effectives" in each military district, and the grand total in the department :

First Military District of South Carolina . . . . .	11,229
Second Military District of South Carolina . . . . .	2,849
Third Military District of South Carolina . . . . .	5,837
District of Georgia (Savannah) . . . . .	10,125
District of Middle Florida . . . . .	1,374
District of East Florida . . . . .	803
Total in the department . . . . .	32,217

<sup>1</sup> *War Records*, vol. xiv. page 889.



The armament of *James Island*, reported by Brigadier-General S. R. Gist, March 3, 1863, was thus disposed :

Fort Johnson, 5 guns (two 10-inch and two 32s and one 32 rifle), with one 10-inch mortar, total . . . . .	6 guns.
Battery Glover, opposite White Point Garden, in the city, . . . . .	5 "
Battery Means, near the Ashley mouth of Wappoo Cut . . . . .	2 "
Fort Pemberton, near the Stono mouth of Wappoo Cut . . . . .	15 "
Western division of lines (2600 yards) . . . . .	17 "
Eastern division of lines (2600 yards) . . . . .	20 "
Battery Reed, on the right flank of Fort Lamar . . . . .	2 "
Secessionville (Fort Lamar), 13 guns and 1 mortar . . . . .	14 "

*James Island* was therefore at that time defended by an aggregate of 81 guns, of which only 13 were on the harbor.

*Morris Island* had in its principal work, Battery Wagner, at this time, only 7 guns; and in Battery Gregg, at Cumming's Point, only 2 guns; total, 9 guns.

*Sullivan's Island* was armed as follows: Breach Inlet Battery (Marshall), 8 guns; Beauregard Battery, 6 guns; Fort Moultrie, 24 guns; Battery Bee, 10 guns; total, 48 guns.

*Fort Sumter's* armament consisted of 40 guns in casemate and 45 in barbette on the ramparts, making a total of 85 guns, with 7 mortars. Of this aggregate, only the guns of the eastern or right face and flank were to be brought into action—viz. 37 guns and 7 mortars. But as among them were 13 smoothbore 32-pounders, pieces of no value against armored vessels, and as, besides, the fire of the mortars would be very uncertain, the actual armament of the fort likely to prove effective in the approaching struggle could be no more than 24 guns.<sup>1</sup>

The garrison consisted of seven companies of the First regiment of South Carolina Artillery (regulars), commanded by Colonel Alfred Rhett, Lieutenant-Colonel Joseph A. Yates, and Major Ormsby Blanding, making a total of about 550 officers and men. Under strict discipline, with constant drill and practice, the garrison had attained the highest degree of excellence.

<sup>1</sup> The weight or calibre of these pieces was as follows: four 10-inch columbiads, two 9-inch Dahlgrens, two 7-inch Brooke rifles, eight 8-inch columbiads and navy shell-guns, seven 42-pounders, rifled and banded, and one 32-pounder, rifled and banded. The mortars were of the 10-inch sea-coast pattern.

An afternoon trip down the harbor to see the dress-parade and hear the band play at Fort Sumter was held by the Charlestonians to be an indispensable custom—a tribute due both to the war spirit of the time and to the merit of a fine command. (An idea of the organization of the regiment, its companies and officers, may be formed from reading Colonel Rhett's report of April 7, 1863, in the Appendix of this work.)<sup>1</sup>

<sup>1</sup> It appears that one of the biographers of General R. E. Lee has, in unconscious affection for his noble chief, greatly exaggerated the extent and value of the defensive works ordered and constructed during his command of the Department of South Carolina and Georgia, from November 8, 1861, to March 3, 1862, a period of only four months. (See *Memoirs of Lee*, by A. L. Long, chap. viii.) At the time of General Lee's departure for Virginia no problem of iron-clad warfare had yet presented itself, and except perhaps the "Thunderbolt" batteries below Savannah and the first works at Battery Bee, Sullivan's Island, Charleston harbor, there were no fortifications along the coast that General Lee would have estimated very highly, and none as constituting "a strong interior line of defense extending from Winyaw Bay to the mouth of the St. Mary's River." From March to September some changes, and a few only which were advantageous, were made by order of Major-General Pemberton. But it was not until the administration of General Beauregard and his chief engineer, Colonel Harris, that the defenses on the coast attained the high degree of excellence for which they became distinguished. The correction of General Long's error was made in June, 1876, by General Thomas Jordan, writing for the Southern Historical Society a paper on this subject. The present writer feels called upon to add his testimony to that of General Jordan.

## CHAPTER II.

### THE REPULSE OF THE IRON-CLAD SQUADRON, APRIL 7, 1863.

CONFIDENCE OF THE NORTHERN MIND IN ARMORED VESSELS AND THE CAPTURE OF CHARLESTON BY THEM—COMBINED OPERATIONS PREPARED UNDER REAR-ADMIRAL DUPONT AND MAJOR-GENERAL HUNTER—RENDEZVOUS OF THE SQUADRON AT PORT ROYAL—EXPERIMENTAL ATTACKS ON FORT McALLISTER ON THE COAST OF GEORGIA—DUPONT'S DISTRUST OF THE VESSELS INCREASED—SQUADRON CROSSES CHARLESTON BAR—FORCE AND ARMAMENT OF THE SQUADRON—GENERAL BEAUREGARD IN COMMAND OF THE DEFENSE—TWO CONFEDERATE IRON-CLAD RAMS STATIONED WITHIN THE OBSTRUCTIONS—ADVANCE OF THE SQUADRON APRIL 7TH—SPIRIT OF THE GARRISON OF FORT SUMTER UNDER COLONEL RHETT—FORT MOULTRIE OPENS FIRE—ACTION BEGUN BY THE FIRST DIVISION OF FOUR MONITORS—FLAGSHIP NEW IRONSIDES SLOW TO ADVANCE—DRIFTS ALMOST OUT OF RANGE—WEEHAWKEN FEARS TO PUSH HER RAFT AGAINST OBSTRUCTIONS—PASSAIC DROPS OUT OF RANGE TO REPAIR DAMAGES—FOUR VESSELS OF SECOND DIVISION MOVE FORWARD INTO ACTION, NAHANT AND KEOKUK COMING NEAREST OF ALL—FORT SUMTER'S FIRE BECOMES MOST EFFECTIVE—REAR-ADMIRAL SIGNALS TO WITHDRAW FROM ACTION—HIS CAPTAINS REPORT FIVE OUT OF EIGHT VESSELS MORE OR LESS DISABLED—FORT SUMTER'S INJURIES—TOTAL FIRING AND CASUALTIES ON BOTH SIDES—KEOKUK SINKS NEXT MORNING—ESTIMATES OF RANGE AND OBSTRUCTION COMPARED—MR. SWINTON'S TESTIMONY TO CONFEDERATE ARTILLERISTS.

THE capture of Charleston by a strong force of armored vessels, to be supported, if necessary, by troops operating on land, seems to have been almost the first thing determined on by the United States Navy Department after the fight in Hampton Roads between the Monitor and Merrimac (Virginia).<sup>1</sup> That conflict marked the first real epoch in the history of iron-clad warfare: the second was made memorable by the attack on Fort Sumter, now to be related.

Only thirteen months intervened between the two events. In

<sup>1</sup> See Appendix for Secretary Welles's confidential despatches to Flag-Officer DuPont.



Rear-Admiral SAMUEL F. DUPONT, U. S. N.,

Commanding S. A. B. Squadron 1862-63

From a Photograph.

Native of New Jersey; entered U. S. Navy in 1815; Lieutenant 1826;

Commander 1843; Captain 1856; Commanding Philadelphia

Navy Yard Jan., 1861; Flag Officer Port Royal, S. C.,

Nov., 1861.



that period of time the Federal power had remedied many defects in the construction of "monitors," and had substituted for the XI-inch smoothbore Dahlgren guns the heavier metal of XV-inch smoothbore guns and 8-inch Parrott rifles, the former throwing projectiles of 440 pounds, the latter of 155 pounds weight. The Confederates had been cut off from all other than their own very limited resources of manufacture, and had not been able to improve on either the masonry forts of the day or on the ordnance used by the Virginia. The best their government could do was to arm its forts with the then old-fashioned 10-inch columbiads (smoothbore) and a few VII-inch rifle cannon of the pattern invented by Lieutenant John M. Brooke of the Confederate Navy. The columbiads threw projectiles of 128 pounds; the rifles threw shells and bolts from 100 to 133 pounds in weight.

But it was not until the early months of the next year (1863) that preparations were actively begun on the coast of South Carolina. The flag-officer of the South Atlantic blockading squadron, Captain Samuel F. DuPont, distinguished for his success in forcing an entrance into Port Royal, between Charleston and Savannah, November 7, 1861, was made rear-admiral, and for his captains he seems to have drawn around him some of the finest officers of the service. The War Office in January placed Major-General David Hunter in command of the Department of the South; and in February he was joined at Port Royal by Major-General J. G. Foster, coming from the coast of North Carolina with 10,000 infantry and 600 artillery. Soon after Stono Inlet and Folly Island were occupied by them.<sup>1</sup> But dissension between the two generals resulted in Foster's returning North, and leaving his command to serve under Hunter in the expedition against Charleston. When the rear-admiral was ready to move Major-General Hunter was prepared to co-operate with him, by the way of Folly and Morris Islands, with a force of thirteen thousand men.

The squadron made its first rendezvous at Port Royal. While its vessels were assembling there three or four of the monitors

<sup>1</sup> Cole's Island, within Stono Inlet, having been abandoned by the Confederates the year before, was occupied by Union troops March 28, 1863.

were ordered to make experiment on Fort McAllister, a fortification located near the mouth of the Great Ogeechee River on the adjacent coast of Georgia. Here in January, February, and March four trials were made, the last being for eight hours, with

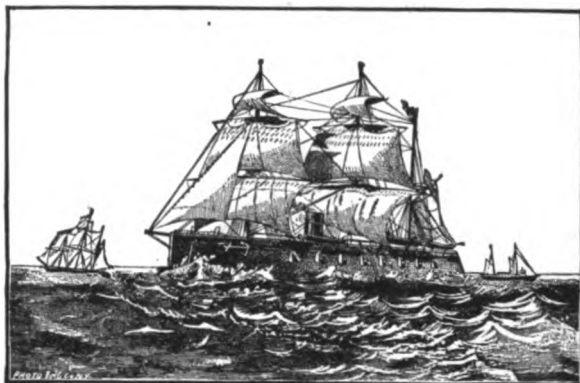

IRON-CLAD FRIGATE NEW IRONSIDES.

(When stationed off Charleston she appeared without masts or sails.)

the Passaic, Patapsco, and Nahant, "the Montauk, having been three times under fire of the fort and sufficiently tested," not joining in on this occasion. The Passaic's deck was "very badly injured," and altogether the results were not encouraging. Rear-Admiral DuPont reluctantly confessed: "The injuries to the monitors were extensive, and their offensive powers found to be feeble in dealing with forts, particularly earthworks."<sup>1</sup>

While the most confident expectations continued to be indulged in at Washington, and the public mind of the whole North was excited and sanguine on the subject, it was evident that the naval officers themselves were becoming more distrustful of their vessels, or, as one of them expressed it, of "this fighting

<sup>1</sup> Fort McAllister, at Genesis Point, near the mouth of the Great Ogeechee River of Georgia, was a well-built earthwork with heavy parapets and traverses, but with only seven guns and one mortar for its armament. Of these, the largest seems to have been a 10-inch columbiad (smoothbore). Major George W. Anderson, Jr., the commander, distinguished himself on these occasions, and even when, later, he was forced by overwhelming numbers from Sherman's army to surrender the post after a brave resistance, with hand-to-hand fighting on the parapets. This was shortly before the fall of Savannah, in December, 1864.

by machinery." War-correspondents had been engaged for months and were awaiting the signal of conflict. It is not too much to say that no "coming event" of the war since the first great battle had so held the people of the North in hopeful suspense as this approaching attack on the citadel of Charleston harbor. Mr. Welles wrote to Admiral DuPont: "There is intense anxiety in regard to your operations."

It should be borne in mind that the squadron included three distinct classes of armored vessels:

1. The "monitors," represented by seven of what became known as the Passaic class, differing from the first monitor chiefly in two particulars—viz. (a) the removal of the pilot-house from its position on deck forward of the turret to a better position on the top of the turret; (b) the increased thickness of the armor of the turret from eight to eleven inches, and of the timber backing of the iron-clad hull. The seven vessels of this class were the Passaic, Montauk, Patapsco, Weehawken, Nantucket, Catskill, and Nahant.

2. The Keokuk, an iron-clad battery differing from the first in showing about five feet of slanting hull above the water-line, in having two fixed turrets, each armed with one XI-inch gun, and in having only six and a quarter inches of armor on the turrets, with deficient plating on the hull also.

3. The New Ironsides, a seagoing screw iron-clad steamer, plated with rolled plates four and a half inches thick, except at the bow and stern, which were bare; having three decks, with an armament of seven XI-inch guns on the broadside and two VIII-inch or 200-pounder rifles on pivots; draught, sixteen feet; displacement, 3500 tons. It was the intention of her builders that she should be bark-rigged, but she served off Charleston without masts or rigging of any sort. (*Appendix B.*)

The squadron carried a total of thirty-two guns, apportioned as follows: twenty-two XI-inch smoothbore, seven XV-inch smoothbore, and three VIII-inch Parrott rifle cannon.

In point of both armament and power of resistance it was to be the most formidable naval attack hitherto made in this or any other country. The British fleet before Sebastopol (1854) appears to have had no guns heavier than 68-pounders.



Thus the attack on Fort Sumter involved the employment of nine armored vessels of three different classes against a casemated fort built of brick and concrete masonry, armed with 80 guns and garrisoned with 550 men. It is true that Fort Moultrie, with other works at the entrance of Charleston harbor, took an active part, though at long range, in the defense, but the attack may be said to have been made entirely on Fort Sumter; for, with the exception of some twenty shots fired at the works on Sullivan's and Morris Islands, the attacking squadron paid no attention to any other object than the one fort it had come to engage.

The second rendezvous of the armored vessels was at North Edisto Entrance, about halfway to Charleston. Here the rear-admiral took his flag April 2d, and stayed a few days, perfecting his arrangements.

In the forenoon of Sunday, April 5th, the fleet of iron-clad vessels, gunboats, and transports began to arrive off Charleston bar, their coming being clearly observed from Fort Sumter, and even from the steeples of the city itself. At the fort it was hailed with the hoisting of flags and the firing of a salute. The afternoon was spent in buoying the channel over the bar. Monday morning the rear-admiral hoisted his flag on the *New Ironsides*, and all the armored vessels crossed the bar, intending to advance that day. But, the weather proving hazy, the time was spent in sounding and buoying the main channel, which lies off Morris Island, while the squadron remained at anchor about four and a half miles to the south-east of Fort Sumter.<sup>1</sup>

Tuesday, April 7, 1863, dawned clear and mild upon land and sea. On board the vessels everything was made ready for action. At all the posts in the harbor an attack was looked for, not with over-confidence of success, because the problem was known to be an entirely untried one, but with perfect firmness and abundant spirit. It became known to the commanding general that additional troops had this day been landed on Folly Island in Stono Inlet, but how far they were destined to co-operate with the naval movement could not be conjectured. Were they to

<sup>1</sup> That very night a blockade-running steamer slipped in past the monitors at anchor, her officers taking them for Confederate iron-clads.

operate with the troops already on Folly Island and move upon Morris Island, keeping close to the squadron, or were they to strike for the city at once by a dash from the Stono River through the weak, attenuated lines of James Island? This latter island was the key to Charleston, to the inner as well as to the outer harbor; and General Beauregard must have been relieved to find that the enemy at this time, as again later in the same year, preferred to operate strictly on the sea-line, and so missed an opportunity of capturing the harbor and city of Charleston.<sup>1</sup>

The total Confederate force in the First Military District around the harbor was 11,229 men. (For full particulars see Chapter I.)

The admiral's plan of attack was to pass the batteries on Morris Island without engaging them, to move around Fort Sumter if he could, and take up a position to the northward and westward of that fortification. Five well-armed gunboats<sup>2</sup> were held in reserve outside the bar to support the iron-clads when attacking Morris Island "after the reduction of Fort Sumter." The order of battle was to be the line ahead, in the following succession:

1. Weehawken,	2 guns,	Captain John Rodgers.	} First Division.
2. Passaic,	2 "	" Percival Drayton.	
3. Montauk,	2 "	" John L. Worden.	
4. Patapsco,	2 "	Commiander Daniel Ammen.	} Flagship.
5. New Ironsides,	16 "	Captain T. Turner.	
6. Catskill,	2 "	Commander G. W. Rodgers.	} Second Division.
7. Nantucket,	2 "	" D. McN. Fairfax.	
8. Nahant,	2 "	" John Downes.	
9. Keokuk,	2 "	" A. C. Rhind.	

<sup>1</sup> Major-General David Hunter had a force of 13,000 men in Stono Inlet and on Folly Island. He wrote the President that on the morning after the attack by the squadron his command was in complete readiness to cross Lighthouse Inlet to Morris Island, and "that he was equipped with 100- and 200 pounders, rifled, sufficient to render Fort Sumter untenable in two days' fire." On the other hand, Rear-Admiral DuPont wrote the Secretary of the Navy: "Had the land forces on this occasion (April 7, 1863) been at all adequate to the emergency, the result might have been all that the country desired."

<sup>2</sup> The Canandaigua, the Housatonic, the Unadilla, the Wissahickon, and the Huron.

It was decided to await the hour of high-water, 10.20 A. M.,<sup>1</sup> and not attack before the ebb-tide could be depended on to assist the steering and prevent any disabled vessel from drifting into the harbor. Accordingly, the signal for advance to battle was not given till 12.15 P. M., that being as early as the pilots advised. It was not, however, promptly obeyed, for the Weehawken, in the lead, was stopped by an accident which delayed the whole squadron for an hour and a half. Just as she began to weigh anchor the chain was caught by one of the grapnels hanging beneath the raft attached to her bow for purposes of protection against torpedoes and obstructions.<sup>2</sup>

Captain Drayton of the Passaic, next in line of battle, signalled for permission to go ahead. But the Weehawken cleared her anchor by 1.45, and then all moved forward slowly against the ebb-tide. As observed from Fort Moultrie in particular, the advance appeared for some time uncertain, so slow was the progress of the line.

At Fort Sumter the movement of the squadron was seen from the first, and all were on the alert. There was time for the garrison to take dinner, and so they dined. Then, at half-past two o'clock, the long-roll was sounded: officers and men, clad in full uniform as for dress-parade, sprang to their posts with a dash of good-will: discipline suppressed the cheering which began. Besides the Confederate garrison flag flown from the principal staff at the northern salient, the flag of the State of South Carolina, a blue field with white crescent and palmetto, was hoisted at the western angle of the gorge ramparts, while the colors of the

<sup>1</sup> *Miller's Almanac*, Charleston, S. C.

<sup>2</sup> This massive raft, devised by Mr. Ericsson, was 50 feet long and 27 feet wide, shaped like a boot-jack, and designed primarily to carry a torpedo to be used in blowing up obstructions. Although this was attached to the bow of the leading vessel, the Weehawken, as she advanced to action, the torpedo had purposely been left behind, as likely to do more harm to friends than enemies. Captain John Rodgers thought the raft might be useful with grapnels hanging from it to catch obstructions, and for that reason only he took it into action. But it was never tested against the obstructions for which it was designed. Some time toward the close of the day it was cut adrift, having been found to start the 5-inch armor on the bow, and it floated up on the beach of Morris Island. There it was examined and a drawing of it made by the Confederates.

First regiment floated from the eastern angle of the same. Colonel Rhett ordered at the hoisting of these flags a salute of thirteen guns to be fired and the band of the regiment to play on the ramparts in the hearing of the enemy. Major Blanding took his station in command of the casemates; Lieutenant-Colonel Yates was in charge of all the open-air batteries; and the colonel commanding, choosing for his point of view the vicinity of the Brooke rifle, could be seen from all parts of the fort standing on the parapet of the south-eastern angle, a few others in company with him, silently watching the approach of the vessels. (See Appendix, Colonel Rhett's report.)

Meanwhile, Battery Wagner had been reached by the squadron passing in line ahead slowly to the front. Neither side was disposed to fire: the time had not yet come. The hush of a breathless suspense was everywhere around the scene. The very waters seemed to smooth the way, so calm and all but glassy did they appear, swelling gently beneath the blue sky and bright sunshine of that April afternoon. But on the forts and batteries guarding the entrance to the harbor, where the artillerists stood ready by their guns, the light of battle was already kindling in the soldiers' eyes, and within the dark, iron turrets of the fleet the sailors too were girding themselves for the fight. No unconcerned spectator was present that day. From the gunboats outside the bar, where the Northern war-correspondents had secured a place, up to the western limits of the picture, where the city



From "Modern Ships of War."

THE MONITOR PASSAIC.

Copyright, 1887, by Harper & Brothers.

When on active service the deck was cleared of all masts, stanchions, awning-frames, etc.: only the turret, pilot-house, and smoke-stack were visible.

closed the view, the lookers-on had their whole hearts in the issue. A glance toward the inner circle of the harbor would take in the hulls of the *Chicora* and *Palmetto State*, Confederate iron-clads, stationed inside the obstructions of the Middle Ground, steaming slowly and silently like sentinels pacing their beats; the forts and batteries on the shores which narrowed in the dis-

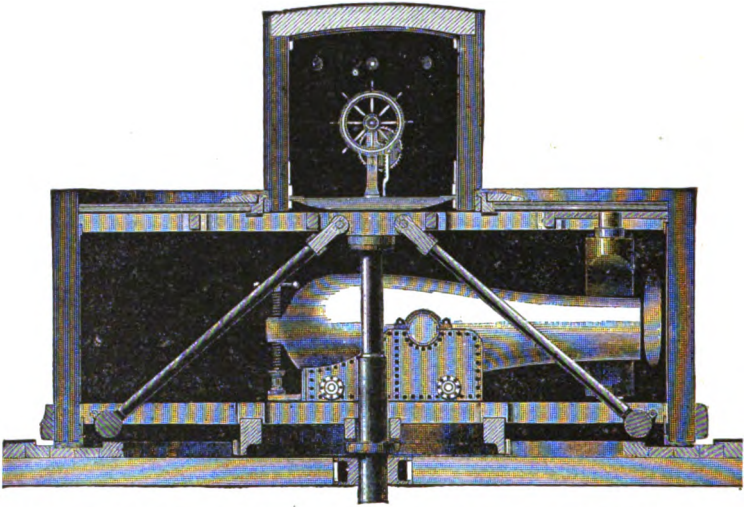

TRANSVERSE SECTION OF TURRET AND PILOT-HOUSE OF THE PASSAIC CLASS OF MONITORS.

tance, as if to clasp the city in their guardian arms; the throng of citizens gathering every moment on the wharves, crowding the long reach of the Promenade Battery and occupying every high place on the water-front which could give them a view of the conflict, then so near at hand.

At last, just before the leading monitor had come abreast of Fort Sumter, a puff of white smoke from Fort Moultrie rolled up in curling clouds from the shore of Sullivan's Island, and the next moment the stillness of the harbor was broken by the heavy report of the first gun. This was at ten minutes before three o'clock. But the range was too great for Moultrie's columbiads, and the fire was suspended for a little while. One gun from the *Passaic*, second in line, was fired in reply. By this

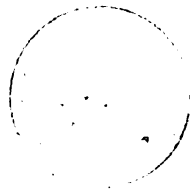



head, had  
well-known  
channel east  
barbette  
d on this  
at three  
the guns  
Batteries  
h Battery

ed speed,  
and divis-  
, then to  
which way  
the appear-  
of steam

On board  
ng.<sup>1</sup> These  
nt of steam  
n the shore,  
fusion in the  
become disar-

Passaic, the  
structions. But  
powerful broad-  
instead of halt-  
g drifting farther  
from Fort Sumter.

mediately over the  
nd connected with it  
e officer in charge at  
Cheves, tried in vain  
on never discovered the

depth of the channel in that  
a width of about a half mile,  
on the inner edge of the chan-  
ed on the map. She  
Confederate





closed the view, the lookers-on had their whole hearts in the issue. A glance toward the inner circle of the harbor would take in the hulls of the *Chicora* and *Palmetto State*, Confederate iron-clads, stationed inside the obstructions of the Middle Ground, steaming slowly and silently like sentinels pacing their beats; the forts and batteries on the shores which narrowed in the dis-

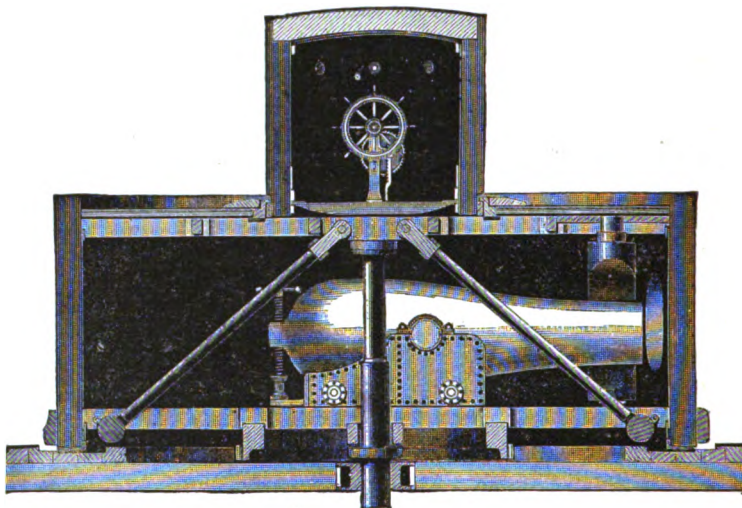

TRANSVERSE SECTION OF TURRET AND PILOT-HOUSE OF THE PASSAIC CLASS OF MONITORS.

tance, as if to clasp the city in their guardian arms; the throng of citizens gathering every moment on the wharves, crowding the long reach of the Promenade Battery and occupying every high place on the water-front which could give them a view of the conflict, then so near at hand.

At last, just before the leading monitor had come abreast of Fort Sumter, a puff of white smoke from Fort Moultrie rolled up in curling clouds from the shore of Sullivan's Island, and the next moment the stillness of the harbor was broken by the heavy report of the first gun. This was at ten minutes before three o'clock. But the range was too great for Moultrie's columbiads, and the fire was suspended for a little while. One gun from the *Passaic*, second in line, was fired in reply. By this

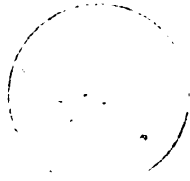



Colonel ALFRED RHETT, First Regiment S. C. Artillery,  
Commanding Fort Sumter 1862-63.  
From a Photograph

time the leading monitor, Weehawken, with raft ahead, had opened on Fort Sumter before she had reached a well-known buoy placed by the Confederates at the turn of the channel east of Fort Sumter and distant from it 1120 yards. The barbette guns of the eastern flank of the fort, previously trained on this buoy, opened fire "by battery" on the Weehawken at three o'clock, as soon as she reached that object. Then all the guns that could be brought to bear, from Fort Moultrie, Batteries Bee and Beauregard on Sullivan's Island, together with Battery Gregg at Cumming's Point, joined in with Sumter.

At this time the flagship, *New Ironsides*, slackened speed, being about a mile from Fort Sumter, with the second division of the squadron in the rear. First to one side, then to the other, her bow pointed, as though hesitating which way to swing round with the ebb-tide. She had all the appearance of a ship becoming unmanageable from lack of steam and headway, rather than from power of tideway. On board they believed her to be in great danger of grounding.<sup>1</sup> These movements of the flagship, whether from the want of steam or of steering qualities, were not only noticed from the shore, but they excited also the greatest surprise and confusion in the squadron itself. True, the line in front had become disarranged by the backing of the *Weehawken* and *Passaic*, the former not daring to try the raft upon the obstructions. But all expected the iron-clad frigate, with her powerful broadside of seven XI-inch guns, to move forward instead of halting at the distance of one mile, and before long drifting farther yet to a distance of over two thousand yards from Fort Sumter. About this time she was thought to be immediately over the large boiler torpedo off Battery Wagner and connected with it by electric wire. (See Chapter I.) The officer in charge at that post, Assistant Engineer Langdon Cheves, tried in vain to ignite the charge, and for some reason never discovered the

<sup>1</sup> As her draught was sixteen feet, and the depth of the channel in that vicinity was from twenty to fifty-four feet for a width of about a half mile, the conclusion is, that she must have been on the eastern edge of the channel, and not in mid-channel, as represented on Major Echols's map. She must have been farther off from Fort Sumter than even the Confederate estimate of her distance. (Appendix B.)

steam-frigate escaped the hidden danger. (See Appendix B.) Her stopping threw the line behind her into such confusion that she ran foul of the Catskill and the Nantucket, and she finally signalled at 3.20 P. M. that the squadron should disregard the movements of the flagship.

At Fort Sumter the stir of that first period of the fight was intense. The scene within the fort, so changed from the fixed attitude an hour before expecting the attack, was now one of the utmost activity consistent with perfect discipline and steadiness of conduct. The gunners of the batteries engaged were kept incessantly in motion serving their pieces, whether seen along the ramparts canopied with smoke or observed flitting with gleams of red and gray uniform in and out of the shadows of the lower casemates. Up and down the spiral stairways sped the runners to and from the magazines. Men, and sometimes officers, hurried about with orders and messages in every direction, while the ear but slowly grew accustomed to the thunder of the heavy guns and the mind braced itself for the crisis of the battle.

The first shots fired at the fort came from the leading monitor, Weehawken. One passed over the heads of the men standing ready to fire the barbette guns of the right flank, and cut a clean hole through the regimental flag flying on the gorge-wall, piercing it near the crossing of the two cannons in the centre of its field. Another shot threw down a shower of bricks from the traverse at the eastern angle upon the heads of the men near by, slightly wounding some of them. One of the largest shells, exploding near the water's edge at the base of the eastern wall, sent up over the parapet a column of sea-water, to fall in a cascade of spray over the guns and the new uniform of Adjutant S. C. Boylston, filling the crown of his scarlet cap like an overflowing saucer. Another shell, penetrating entirely through the scarp-wall on the level of the upper-tier embrasures, or rather where these had been hastily bricked up, set fire in bursting to some straw bedding left in the soldiers' quarters on that eastern side of the fort. From the barracks of the western flank, exposed to a reverse fire, all such combustibles had been removed, but it was thought that no single shell could breach the wall, as

this one did, and therefore the beds had been left. The accident was alarming; the service of the guns overhead and of the magazines adjacent was imperilled. But the prompt and efficient conduct of a well-organized fire department with engine and hose, directed by the officer of the day, Lieutenant Charles Inglesby, averted the danger. Another alarm, caused by a shell's bursting in the western barracks, proved to be less dangerous. At first the firing of the fort was by battery and very quick, as it was thought that the vessels would attempt to run past the forts and enter the harbor. But as the firing progressed the practice became more deliberate, accurate, and effective. Not long after the action began the total of guns engaged on the eastern flank was reduced one-half by an order from the colonel commanding. The smoke arising from the lighter guns in the lower casemates was found to obscure the view from the parapet, and this gave good reason for the closing of their embrasures. But as soon as the foremost monitors came within the field of fire of the right or north-eastern face of the fort, opposite Sullivan's Island, the batteries of this quarter combined with the first engaged.

On board the first division of the squadron, the monitors Weehawken, Passaic, Montauk, and Patapsco, the twenty minutes of action had been full of incident. But it became only too evident that the defensive advantages of the armored vessels had been attained at the expense of their offensive power. How it must have chafed the spirits of those captains to be bound by machinery to fire only as the turret revolved, or to find it jammed and refusing to turn when they were ready to fire; to peep through little loopholes at the forts and much-dreaded obstructions; to conduct signalling and sounding under cover of the turret, where that was found practicable! The Weehawken and Patapsco must each have been hit more than once per minute, while they did not, both together, fire as often as once per minute. Between the two they managed to put in only eighteen shots in those twenty minutes; and in the same period of time two of the eight heavy guns carried by this division had been disabled.

It will be remembered that it was at twenty minutes past

three the flagship signalled the squadron to disregard her eccentric movements. It was then that the four vessels of the second division felt at liberty to move to the front. At least fifteen minutes more were required for the leading monitor, Catskill, to get into action. The next in line, Nantucket, opened on Sumter at 3.50; the next, Nahant, about 4 o'clock became hotly engaged with both Sumter and Moultrie. The Keokuk, pushing ahead of her leading companions to a station reported variously at from six to nine hundred yards from Fort Sumter, opened fire ten minutes after the Nahant.

Now, for the first time since the fight began, did the whole of the squadron become engaged. The forts and batteries also were firing with more steadiness and combined effect than they had hitherto attained. Upward of one hundred of the heaviest cannon of all descriptions were flashing and thundering together, shooting their balls, their shells, and fiery bolts with deafening sound and shocks of powerful impact that surpassed all previous experience of war. The smoke of the battle, brightened by the sun into snowy clouds, seemed to the distant observer entirely to envelop the small objects on the water which were causing all the trouble. Only when the light breeze availed to lift or part and roll away slowly the heavy masses could a glimpse be had of the movements of the squadron. The water all around the fighting ships was seen on nearer view to be constantly cut, ploughed, and splashed with every form of disturbance, from the light dip of the ricochet shot to the plunge of the point-blank missile, from the pattering of broken pieces of solid shot falling back from the impenetrable turrets to the sudden spout of foam and jet of spray sent up by a chance mortar-shell exploding just beneath the surface of the water. Sometimes from the same cause a waterspout raised near the fort would reach to a great height and throw its shower of descending spray upon the guns frowning over the parapet or in the act of discharging their own messengers of defiance.

The monitors of the first division needed all the help their comrades could bring them. The Passaic had been already taken out of action by Captain Drayton to the eastward, had come to anchor, and was inspecting damages. The Weehawken,

after declining to push against the obstructions with the raft brought for that very purpose, was holding back, but kept up a fire on the fort. The Patapsco must have run aground, for that alone explains a stoppage attributed to obstructions where it is known certainly that none had ever been placed. Backing, she got off, but had been held sufficiently long to receive special attention from the Confederate gunners. The Catskill, coming to the front from the rear of the flagship, passed some of the first division in their damaged condition. Both this vessel and the Nantucket of the second division were warmly greeted by the forts, the latter losing the use of her XV-inch gun after the third discharge. But it was reserved for the last to be first, for the Nahant and the Keokuk, last in line, among the last to get into action, were the first to move up nearer to the enemy, to fight at shorter range than the rest and to suffer the consequences.

Commander John Downes took the Nahant into the hottest fire of the forts, but while he could fire only fifteen times his alert adversaries jammed his turret with three blows from heavy shot, put his steering-gear out of order, and caused his vessel to drift, unmanageable for a while, nearer to the forts than any of her colleagues, with the risk of being carried by the flood-tide, then setting in from the bar, upon certain destruction. By strenuous exertion a new arrangement was made for steering, and the ship was saved, but her guns could not be brought to bear, and she had to withdraw from action to repair damages.

It fared still worse with the Keokuk. The defects of her build have been alluded to, and they must have been suspected at the time. But how serious they were remained to be proved by Commander Rhind's willingness to test to the utmost her fighting capacity. When the turn in the channel was reached he came "bow on" to Fort Sumter, receiving the concentrated fire of all the guns that could be brought to bear from that post and from Sullivan's Island. He was silenced after firing but three shots from the gun in his forward turret and none from the after one. The position taken seemed to him about five hundred and fifty yards from Sumter. To those in the fort it appeared to be hardly less than nine hundred yards. At the end



of twenty-five or thirty minutes he was glad to escape without being captured or going down in the presence of his enemy. His vessel was struck ninety times in the hull and turrets. Nineteen shots pierced her through at and just below the water-line. The turrets were entirely penetrated by rifle-bolts and 10-inch round shot. One of his turret-ports was closed by the blow of a shot jamming the shutter against the gun. Riddled as she was, it is a matter of wonder how the *Keokuk* escaped with her engines in condition to take her slowly out of the fight. Kept afloat with difficulty that night, she sank at her anchorage off the southern part of Morris Island early next morning.

Meanwhile, the order to withdraw from action had been issued. The hour, according to the rear-admiral, was 4.30 P. M., but Fleet-Captain C. R. P. Rodgers thought it nearly five o'clock when the signal was given. The firing of the squadron slackened and ceased, but the forts kept it up until the vessels passed out of extreme range, the last shots being fired by Battery Wagner, which had been silent up to this time.

If little has been said thus far of the flagship it has been because there was little to be said. Inviting the aim of the enemy by her larger bulk, and distrusted more than the monitors by the rear-admiral, the *New Ironsides* was held at twice the distance of the other vessels from the fire of the forts—viz. at from fifteen hundred to more than two thousand yards. Once, toward the middle period of the fight, she was seen by the Confederates to move up the channel as if to fight. But upon receiving the special attention of Forts Moultrie and Sumter she returned, rather promptly, to her former station. She never fired a shot at Fort Sumter, but she did fire seven shots at Moultrie and one at Wagner. Although hit very often, she was entirely proof, at that long range, against the Confederate fire, and, as described by some one on board, the shot dropped from her sides like boys' brickbats from the roof of a house, her efficiency being not in the least impaired, either in her iron- or her wood-work.<sup>1</sup>

<sup>1</sup> In the *Military Operations of General Beauregard* it is said: "Fort Sumter cripples the *New Ironsides*." I have failed to find any authority for that incident. On the contrary, the endurance of this formidable ship of war was

It must have been a solemn procession as it filed past the flagship that serene April evening. The first in action were the first to come out. After they had all passed the Ironsides got under way and followed them. It was then sunset, and after dark the captains of the several vessels came on board the flagship to report to the rear-admiral. The Keokuk was expected to go down at any moment. Her next in line, the Nahant, had both turret and pilot-house injured, the latter very much so, and the deck cut through in places. The Weehawken, leading monitor, had her side-armor broken, exposing the wood, her turret stopped for a time, and her XI-inch gun disabled. The Passaic, second in line, had her turret jammed, the XI-inch gun disabled, and the pilot-house badly wrecked. The Patapsco's rifled gun had been silenced at the fifth fire, the upper part of her armor loosened, her turret temporarily stopped. The Nantucket lost the use of her XV-inch gun at the third fire. The Catskill received a severe hurt on the deck. The Montauk suffered two damaging hits among fourteen on her side-armor, and another blow on her pilot-house.

The rear-admiral fully intended renewing the attack when he suspended it, but after hearing these reports and retiring to sleep over the question, he announced next morning his decision against renewal, for in his judgment "it would have converted a failure into a disaster." In this decision he had the support of all the captains and commanders who had been engaged. But a harsh correspondence ensued between himself and the Secretary of the Navy, leading to DuPont's removal from command of the squadron, June 3, 1863, on account of his unwillingness to renew the attack. (*Appendix F*, Ch. III.) It should be mentioned, in justice to the rear-admiral, that his own and his captains' official reports of the action were suppressed by the Secretary of the Navy for a period of eight months; and it appears that even the Houses of Congress were not fully informed on the subject until they had called for them three

proved five months later when, anchoring off Sullivan's Island, she engaged all the batteries there at twelve hundred yards for nearly three hours, was hit seventy times, yet drew off unhurt and her captain (Rowan) reported no damages. (*Appendix B*.)

times, and more than twelve months after the reports had been sent up to the Navy Department. This delay, exceedingly irritating to the officers in command, was explained by the Secretary as having been necessitated by prudential secrecy in the conduct of the war. (See *Armored Vessels*, Exec. Doc.)

The men-of-war continued at their anchorage, off the southern end of Morris Island, for five days after the fight. Then, on the 12th of April, they crossed the bar and dispersed, the monitors going to Port Royal for repairs, the New Ironsides remaining with the blockaders, outside the bar.

The Confederates took their success with a feeling of relief nearly as great as the joy of victory. They did not learn for months how severely the squadron had suffered; they knew it had failed to meet expectations; they did not know the mortification of defeat felt by its officers nor the storm of national displeasure raised by the Northern newspapers. They knew that the Keokuk had been sunk; they did not know that three or four of her comrades had been disabled for several weeks after the action.

How did Fort Sumter stand it? was the first question asked after the attack was ended. All observers in the garrison that afternoon will remember the prodigious size of those black spheres, fifteen inches in diameter, as they bounded in full view from the ports of the turrets to the walls of the fort. Even the XI-inch shot were larger than any of the Confederate projectiles. The powerful shocks given by these projectiles to the solid masonry of the fort was something new and could never be forgotten. The massive walls, piers, and arches seemed to tremble to their foundations. And when, especially, the bursting of the largest shells occurred at the moment of impact, the loosening, shattering effects attending the shock exceeded all expectations. But about the time when the men were becoming accustomed to the novelty of it the firing stopped, and they had opportunity to inspect damages. In a few places the effect of the fire was severe enough to convince that if continued by other injuries in the same vicinity it would become seriously destructive. But, as a whole, the fort had scarcely lost any of its fighting capacity or real efficiency. Had the fight been

**ELEVATIONS OF FACES OF  
FORT SUMNER**

Showing the Effect of the fire from the  
**FEDERAL IRON-CLAD FLEET**  
7 April 1863.  
Drawn to accompany Engineer Report

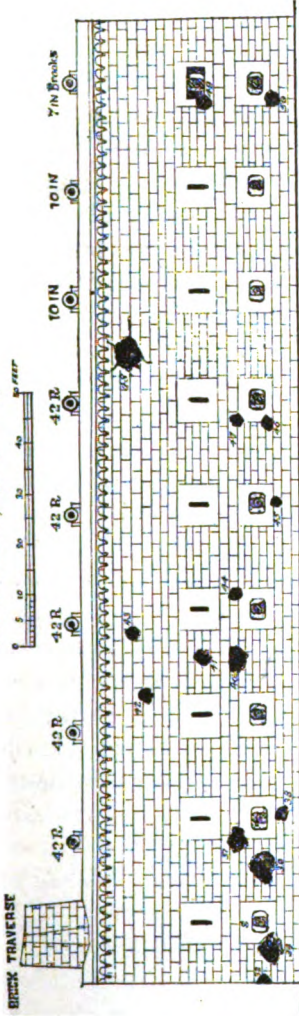

**North East Face.**

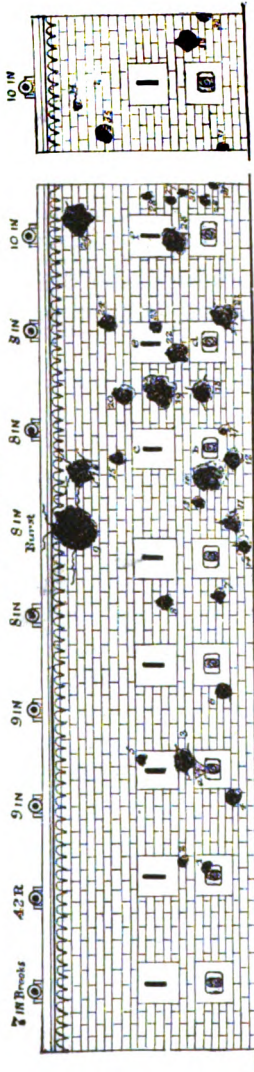

EASTERN OR SEA-FACE.

EAST. ANGLE.

renewed next day, the fort could have done better than the day before, the armament being actually increased in weight on the sea-face by some removals and changes in the night.

On the exposed fronts were the marks of some thirty-four actual hits, mostly separate and distinct, but a few were combined by the effects of two or three shots striking near together. There were some twenty other scars made by scaling, grazing, or bursting of shells, but these did no damage. Indeed, the real damage was done by only fifteen of the total number of hitting shots. Thus four embrasures were injured, two were destroyed; a section of the parapet on the eastern flank was breached and loosened for a length of twenty-five feet, a part of the parapet even falling out and exposing the gun behind it; the scarp-wall of the same front was penetrated at the level of the second-tier embrasures (which had been filled in), and where the wall, five feet thick, was of comparatively fresh material. These complete penetrations had been made by one XI-inch and two XV-inch projectiles from the smoothbore guns. The penetrations elsewhere in the original well-set brick masonry of the fort were much less than was expected, averaging in depth from one foot to two and a half feet, and accompanied with craters of about three feet in diameter. Particular craters, caused by more than one shot, were very serious hurts, one such measuring two feet seven inches in depth, six feet in height, and eight feet in width. The following tabulated statements will exhibit the firing and casualties on both sides:

#### CONFEDERATE POSTS.

NAMES OF POSTS.	Guns engaged.	Shots fired.	Casualties.
Fort Sumter . . . . .	40	810	5 wounded.
Fort Moultrie . . . . .	21	868	1 killed.
Battery Bee . . . . .	6	283	None.
Battery Beauregard . . . . .	3	157	None.
Battery Gregg . . . . .	2	66	None.
Battery Wagner . . . . .	4	22	{ 3 killed and 5 wounded by accidental explosion.
Totals . . . . .	76	2206	4 killed, 10 wounded.

REMARKS.—The official reports do not correspond in all particulars; this statement is from a careful compilation.

Of the total guns engaged, nearly one-fourth were smoothbore 32-pounders, of no value against armored vessels.

Range, from 900 to 2000 yards.

The killed were (Fort Moultrie), Private Lusby accidentally, by falling of flagstaff. The wounded at Fort Sumter, Sergeant Faulkner, Privates Chaplin, Minnix, Penn, and Ahrens. (For Battery Wagner, see Appendix.)

FEDERAL VESSELS.

Names of Vessels.	Guns engaged.	Shots fired.	Hits received.	Casualties.
Weehawken . . . . .	2	26	53	None.
Passaic . . . . .	2	13	35	None.
Montauk . . . . .	2	27	14	None.
Patapsco . . . . .	2	10	47	None.
New Ironsides . . . . .	8	8	93	None.
Catskill . . . . .	2	22	20	None.
Nantucket . . . . .	2	15	51	None.
Nahant . . . . .	2	15	36	1 killed, 6 wounded.
Keokuk . . . . .	1	3	90	16 wounded.
Totals . . . . .	23	139	439	1 killed, 22 wounded.

REMARKS.—These returns are taken from the Executive Document on *Armored Vessels*, with the exception of hits received by the *New Ironsides*, which were given by Rear-Admiral DuPont before the Committee on the Conduct of the War. (Vol. ii., 1865, *Heavy Ordnance*, page 96.)

Range, from 550 to 2000 yards.

From the above statement it appears that in an action lasting two hours and twenty minutes only 139 fires had been made by the vessels against 2206 made by the forts and batteries—that on board seven out of the nine vessels there were no casualties at all. Thus, it was rather a trial of strength than a sanguinary battle. Indeed, compared with the fighting of the iron-clad boats of Captain Eads's construction the year before on the Cumberland and the Tennessee Rivers, when at Fort Henry they were victorious and at Fort Donelson they were beaten, the attack on Fort Sumter was not made with the vigor or persistency that often distinguished the United States Navy, and particularly in forcing an entrance through torpedo obstructions into Mobile Bay the following year.

Some of the captains engaged complained very grievously of the serious want of vision from the pilot-house, both on account of the narrow openings there allowed them and on account of the heavy smoke enveloping the scene of action. And these

complaints serve to explain the great discrepancy between the Union and Confederate estimates of range and obstructions.<sup>1</sup>

First, as regards the range, both sides agree as to the facts of the Nahant's coming in, or drifting in, the nearest of all, the Keokuk next, and the New Ironsides being the farthest of all from Fort Sumter. But when it is considered that the vessels labored under great disadvantages of vision, while the forts had the advantage of knowing the range of a buoy placed at the very turn in the channel where the action occurred, the conclusion is irresistible that the true estimate of ranges belongs to the defense rather than to the attack.

Then, with regard to the obstructions seen by some of the more advanced monitors. More than one naval officer reported these as appearing to be very near or "close aboard." But they were certainly known by the Confederates to be upward of three or four hundred yards farther within the mouth of the harbor than any point reached by the Weehawken, the Nahant, or the Keokuk. They have been commonly mentioned as being on a line between Fort Sumter and Fort Moultrie. This is a mistake: they were originally placed between Sumter and Battery Bee on Sullivan's Island, but had dragged their anchors a little below the line of Battery Bee. They consisted of parts of a broken boom of heavy logs and of a few sections of rope-netting; but there were positively no torpedoes among them or forward of them on that day; and there was, moreover, an opening three hundred yards wide between them and Fort Sumter entirely clear of all obstructions. (See plates at end of volume.)

The result of the action proved the readiness of the South, in at least one place, to meet the strongest effort of the United States Navy. She even proved herself more than equal to the latest inventions, offensive and defensive, in the art of war. The artillery fire of the forts, though by no means that of the heaviest guns of the day, was, for its power and accuracy, the subject of wonder to the officers of the fleet and the war-correspondents on the station.<sup>2</sup> Never before had an attacking

<sup>1</sup> Captains Turner, Drayton, and Worden, and Commander Ammen in their several reports make this very plain.

<sup>2</sup> Much of its effectiveness was due to the superior quality of the powder

naval force presented such very small objects as the monitors to the fire of the enemy. Mr. William Swinton, who was an eye-witness, quoting the remark of Sir Howard Douglass that "there is no telling *what* gunpowder can do," adds: "The rebel artillery practice certainly drew on its resources to an extent hitherto unparalleled in warfare. . . . As one of the leading actions of the great rebellion the battle of Charleston harbor passes into history and takes its place there. As a contribution to the world's experience in the art of iron-clad warfare it passes into science and opens an epoch there."

manufactured at the works in Augusta, Georgia, under Colonel George W. Rains.

"Even when supplying the urgent calls of General Ripley at Charleston for cannon powder to replace the twenty-two thousand pounds consumed during the action with the iron-clad fleet, two days' work nearly supplied that amount.

"Notwithstanding the admirable serving of the heavy artillery at Fort Sumter during that engagement, it would have fallen and Charleston been captured had any but the strongest gunpowder been used. The armor of the iron-clads, though constructed expressly to withstand the heaviest charges and projectiles, gave way before its propelling force."—(*History of the Confederate Powder-Works, Augusta, Ga., 1882.*)



## CHAPTER III.

### THE RECOVERY OF THE GUNS OF THE KEOKUK.

**April-May, 1863.**

SINKING OF THE VESSEL—THE WRECK SEEN FROM FORT SUMTER—FAILURES TO DESTROY IT, AND FINAL ABANDONMENT BY THE FLEET—CONFEDERATES' PLAN FOR RECOVERY OF THE GUNS—MECHANICS, PROTECTED BY GUARDBOATS, ATTACK THE IRON-WORK OF THE TURRETS—TWO WEEKS OCCUPIED IN GETTING THE FIRST GUN READY FOR HOISTING—HULK PREPARED AND TOWED DOWN TO THE WRECK—DIFFICULTIES INCREASE—A CRISIS REACHED AND PASSED—THE FIRST GUN RECOVERED AS DAYLIGHT WAS ABOUT TO DEFEAT THE ENTERPRISE—THE SECOND GUN RECOVERED THREE NIGHTS AFTERWARD—THE CONFEDERATE WRECKERS COMPLIMENTED BY GENERAL BEAUREGARD—THE ADMIRAL BLAMED BY THE AUTHORITIES IN WASHINGTON—INTERCEPTED SIGNALS—NAVAL TACTICS OF THE CONFEDERATE DEFENSE.

AMONG the daring and successful episodes of the Civil War the recovery by the Confederates of the two guns from the wreck of the iron-clad vessel Keokuk deserves a place of the highest distinction. It was something entirely of its own kind, involving mechanical skill and ingenuity, besides secrecy, cool judgment, and unflinching resolution. It is pleasant to add that it was attended by no casualties.

No special documents, official and contemporary, relating to the enterprise have been discovered. A few paragraphs embodied in more general reports constitute all the notes possessed from Confederate sources, while some correspondence between the Union authorities is the sum of contributions from the other side. But of the actors in this marine adventure five have been consulted in the preparation of this narrative, and no particulars have been used to supplement the official record

except such as rest on agreement of evidence or seem to be most probable under all the circumstances.

For a knowledge of the Keokuk's construction, armament, and severe treatment by the Confederate guns in the action before Fort Sumter, April 7, 1863, when her brave commander took the vessel within shorter range than any of her colleagues, reference must be made to Chapter II. of this work. Commander A. C. Rhind's report closes with the sinking of his riddled vessel at 7.30 the morning after the fight. She had been kept afloat during the night in the smooth water, but at daylight it became rough, and in the effort to get the vessel round with the assistance of a tug, she sank in eighteen feet of water (high tide), "completely submerged to the top of her smoke-stack. The officers and crew were all saved, the wounded having been put on board of a tug a few minutes before the Keokuk went down." At the latter period of the ebb-tide the turrets were just visible above water. The wreck lay off the southern extremity of Morris Island and about thirteen hundred yards from the beach. As plainly seen at low tide with the naked eye from the walls of Fort Sumter, it was distant nearly four miles, a little east of south.

It will be remembered that the iron-clad squadron remained at anchor in the same vicinity for five days after the fight. In that time an order must have been given by the rear-admiral to Captain John Rodgers of the Weehawken to blow up the wreck by means of the Ericsson torpedo-raft,<sup>1</sup> since that officer reports his preparations to use it in conjunction with Chief-Engineers E. D. Robie and A. C. Stimers, and their final abandonment of the purpose on account of the swell and uncontrollable action of the structure. What prevented the destruction of the wreck by simpler methods is not recorded. But the Navy Department in Washington asked this very question after the guns had been taken out by the Confederates, and the rear-admiral had no answer to give. (Appendix, Ch. III.)

Soon after the withdrawal of the armored vessels from the

<sup>1</sup> There were two of these rafts: one fell into the hands of the Confederates after Captain Rodgers on the 7th of April had cast it loose from the Weehawken.

channel off Morris Island, where the Keokuk lay, three or four visits of reconnoissance were made to the wreck by Confederate officers in small boats. Two of these were naval officers, and they pronounced the recovery of the guns positively impossible.<sup>1</sup> But after the visit paid the wreck on April 16th by Lieutenant S. Cordes Boylston, adjutant of the garrison at Fort Sumter, and another visit, April 19th, by Major D. B. Harris, Chief Engineer of the Department of South Carolina, Georgia, and Florida, steps were taken by Brigadier-General R. S. Ripley, commanding the First Military District, under instructions from General Beauregard, to organize a gang of mechanics with guard-boats for making the hazardous attempt. The following extract from Major Harris's report, April 23d, will give the best information concerning the Keokuk as she appeared when he examined her :

"Her turrets, within four and a half feet of their tops, had been pierced by four 10-inch round shot and one 7-inch rifle shot, and a wrought-iron Brooke bolt had penetrated seven-eighths of its length and stuck in the plating. Several severe indentations were also observed, near which the plates were warped and the bolts broken or started. The top of the smoke-stack (of sheet iron) was very much torn, and the bottom of it (of similar structure to the turrets) pierced by a 10-inch shot. The vessel having sunk in thirteen feet of water prevented an examination of the lower portions of her turrets or of her hull, which no doubt were served in like manner."

About this time the Northern public was reading the opinion of some letter-writer in the fleet, that all was going on very well and that the work of recovering any spoils from the wreck would be a fruitless task. The war-correspondent writes :

<sup>1</sup> Letter of September 10, 1869, from General Beauregard to the author. There was some notice by the fleet of a visit in daylight to the wreck paid, it is likely, by Colonel Rhett and some of his officers, as appears from the following despatch, dated Fort Sumter, April 20, 1863 :

"CAPTAIN NANCE: The Yankee fleet fired at our boat at the wreck Keokuk. Confederate steamer Chicora steamed out near the wreck, and is exchanging shots with fleet at long range. None of the fleet have crossed the bar. The Ironsides appears to be coming toward our boat.

"W. H. PERONNEAU, *Captain.*"



**Brigadier-General R. S. RIPLEY, P. A. C. S.,  
Commander First Military District S. C.**

**From a Photograph.**

**Entered U. S. Mil. Academy from Ohio—Graduated 1843;**

**Brevet Capt. and Major of Artillery in Mexican War;**

**Resigned from Army in 1853;**

**In Command of Confederates at Fort Moultrie, S. C., April 12-14, 1861;**

**Brigadier-General Commanding First Mil. District S. C., 1862-65;**

**Died 1887.**



“An effort was made last night to blow up the Keokuk by Captain Rodgers, Lieutenant Mackenzie, Chief-Engineer Robie, and Chief-Engineer Newell of this ship, but without success. She was found to be full of sand, and it was impossible at that time to put the magazine of powder below her deck to blow her up. This morning an effort was made to fix on the raft, with a torpedo attached, to the bow of the Weehawken, but the sea was too rough inside, and after breaking all the lashing repeatedly the effort was given up. To-night another attempt will be made to blow her up, and, as the weather is fair, it is likely to be successful. At all events, she is useless to the rebels. She is filled with sand, and will be broken up or buried after the first gale. The rebels cannot raise her, and she is covered by the guns of the blockading fleet, and will ever be beyond their reach.”

Before operations could be begun upon the wreck the commanding officers were busied looking around and selecting the right kind of men for the undertaking. In the employ of the Ordnance Department was Adolphus W. LaCoste, a native civilian, a rigger by trade, who had been for a long time rendering invaluable service in mounting heavy guns and performing such-like duties. After long and special conference, General Beauregard placed him in charge of the work. All were agreed as to this selection, and even deferred entirely to his judgment in deciding finally to make the attempt. They felt then, as the sequel proved, that he was indispensable to them.

Together with A. W. LaCoste a gang of picked men was organized, consisting of his brother, James C. LaCoste, Asa Butterfield, Jack Baker and Edwin Watson, colored, Philip Petrina, Laurence Brionwitch, Thomas Loftus, James Dugan, Edward Garden, John Garden; the following being added from the garrison of Fort Sumter: Sergeant D. H. Welch, Company E, Sergeant Chambers, Artificer John E. Cullum, Company B, Private Thomas Durkin, Company B, and a few others whose names have not been preserved. With these skilled workmen it was necessary to combine a covering force, and Fort Sumter was called upon again to furnish an officer with a detachment in barges to facilitate escape by gaining some little time with a show of resistance.

The two turrets of the Keokuk, each armed with one XI-inch Dahlgren gun, were of conical shape, having a lower diameter of twenty and an upper of fourteen feet. These were exposed at low water, but so little that no more than two and a half hours' labor on each night could be expected under the most favorable circumstances. The enterprise was thus conditioned and limited by the following necessities: viz. darkness, secrecy, quiet, short time, smooth water, and perpetual vigilance. Morris Island was then entirely held by the Confederates, and escape from the wreck would have to be by a rapid pull for the beach, about thirteen hundred yards distant. Outside the bar were strung the blockading gunboats and their protector, the *New Ironsides*: the nearest of them might be on her station two miles off, but there was nothing to prevent their crossing the bar by day or night, while small armed boats might make a dash upon the wreckers at any time and capture every one of them. Later, when the force of workmen was increased and more was at stake, one or both of the Confederate iron-clads took a covering position in the vicinity of the party.

The first thing to be done was to convey the workmen to the wreck with their tools, then push off and stand guard some distance out and down the channel in the small boat or boats provided. The party was for many nights under Adjutant Boylston, but occasionally he would be relieved by Lieutenants Julius M. Rhett and K. Kemper of the same regiment, First South Carolina (regular) Artillery.

With slippery footing on the tops or roofing of the turrets, constantly awash with the swell of the ocean breaking over them, their scant clothing kept wet with the salt spray, and no light allowed them, the mechanics bend themselves to the work. The first turret is attacked with sledge and chisel, wrench and crowbar, for nothing less than the removal of a large section of the roof will satisfy them, sufficient to allow the lifting and free passage of a gun thirteen feet five inches long, nearly three feet in diameter at the breech, and weighing sixteen thousand pounds.

Two thicknesses of inch or inch and a half iron, held up by girders of the same material set close together, and ceiled

on the under side with one thickness of iron plate, constituted the first obstacles to be overcome. Besides the upper and lower plating, three of the heavy girders had to be cut through, each in two places, and removed. Then the gun, seen below on its carriage, mostly under water, could not be made ready for lifting until two massive cap-squares of brass confining it to the carriage were cut and wrenched out of place. The elevating screw, removed from the cascabel, gives place to a strong rope or hawser passed through the cascabel and wrapped around the breech of the gun with lashings sufficient to sling it to the hoisting tackle.

LaCoste had all now in readiness for the crowning act. The gun had been prepared for him by the artificers, who labored at first a whole week in cutting through the roof, and were further delayed by the difficulties encountered within the turret. Altogether, more than two weeks were consumed in cutting through both turrets and in getting the first gun ready to be hoisted out of its watery bed. The spirit of the brave fellows rose with the perils they were encountering and the success that had thus far rewarded them. On one night only were they discovered by the enemy and forced to hurry away from the wreck; but even then no unfavorable results followed, and it appeared probable that neither their earnest purpose nor their actual work for the recovery of the guns was suspected. The war-correspondent's confidence must have been shared by the whole fleet.

Yet, while more hopeful than when they began, the wreckers knew that the most uncertain stage of their operations was to come. They knew that success meant nothing short of seeing those guns on their way to Charleston. But the hoisting out of their enormous masses from the turrets,—how was this to be accomplished? When the final preparations for the removal of the first gun were completed, a favorable night in the early part of May was chosen, and a carefully-planned expedition to the wreck set out from the city, stopping at Fort Sumter on its way down the harbor.

An old but solid hulk, a lightship formerly in use at Rattlesnake Shoal, north of the harbor, was made ready for the hoisting and transporting of the guns to the city. From the



bow projected two outriggers of timber fourteen inches square and twenty feet long, arranged with blocks, stays,<sup>1</sup> and tackle ready for the work, while, to suit the necessity of a lift from the low level of the submerged guns in the wreck, the bow was weighted down with fifteen hundred sandbags, destined to play, subsequently, a yet more important part in the execution of the plan.

Then it became necessary to provide more force and more protection than heretofore, for the crisis of the enterprise had at length arrived. The Navy Department was called on to furnish the valuable services of one or both of its two iron-clad gunboats—the *Chicora*, Captain J. R. Tucker, and the *Palmetto State*, Lieutenant-commanding John Rutledge—to take their station in the main channel and guard the working-party. This protection was increased by another detachment of fifty men from Fort Sumter, and the whole force, with the lightship, was then towed down to the wreck by the transport-steamer *Etiwan*, Captain W. T. McNelty, whose courage and faithfulness in the nightly supplying of Morris Island and Fort Sumter became afterward so conspicuous.

Secrecy and despatch were never more the requisites of success than at this juncture. The Union fleet lay outside, and even some of their small boats on picket-duty could be descried from the deck of the *Etiwan*. But so lulled into confidence were they that no interruption whatever occurred from this quarter. The background of the sandhills of Morris Island must have obscured and favored the movements of the Confederates.

On reaching the wreck the hulk of the lightship was made fast to the nearly submerged turret, and then began the earnest work of the night. Lieutenants Boylston and Rhett were there in command of the detail from their regiment, but they all accorded to LaCoste the directing of the delicate operations, and vied with each other in encouraging their men to render him obedience with a good will and a pull all together. With the slinging of the gun safely effected came the order to hoist away, the men on the lightship responding cheerily, though with the

<sup>1</sup> These were attached to a jury-mast stepped in place of the foremast of the lightship.

hush of caution, to their comrades waist-deep in water within the iron turret. The strain begins, the stout ropes tighten, the block slowly rises ; then the massive breech of the gun appears, inch by inch, above the level of the roofing, the muzzle yet hanging far down below it and splashed by the swell of seawater. The same swell outside the turret was making everything on board the hulk unsteady, save the earnest, lively pull of the men and the dauntless spirit of their leaders. Stick to it as they did, the task was a heavy one, the progress slow, the operation very delicate.

The muzzle of the gun, as was said, was hanging down within the turret, while the heavy breech, hoisted out and clear, was at this stage swaying and swinging freely with the roll of the lightship. Had the contrivance been higher above the water, the capacity of its blocks and tackle would have been sufficient for all purposes ; but already the two blocks were nearly touching each other, and the falls could do no more toward pulling the muzzle free of the turret. There it sloped down to the water, grating and grinding upon the edge of the iron roofing, but refusing to be dislodged by any further application of muscular strength. Equal to the emergency, LaCoste was not to be thwarted, but, looking a moment to the bow of the hulk, weighted down with sandbags in order to reach the lowest level of the hoist, he resorted to what he hoped would give him instant success.

“Shift the deck-load, boys ! Handle those sandbags ! Pass them to the stern !” were orders uttered with earnestness and obeyed with alacrity. The men made fast their rope, and sprang to the bow, where the bags of sand, piled up by hundreds, awaited their removal. As they were taken off, the bow, heaving with the tide and becoming more buoyant every minute, gradually responded to the lightening of its load and the lifting force now exerted by the weighting down of the opposite end of the boat. The gun is plainly rising : it is almost clear ; another minute and it promises to swing free from the restraining edge of the Keokuk’s turret. But no, not yet ! The last bag of sand has been transferred from bow to stern, and human ingenuity can do no more.

How must those hardy men have felt as they paused from their work to consider again what could be done—some vexed to see their prize, so long toiled for, about to be snatched from their grasp; others chilled with forebodings of failure and disheartened by disappointment until almost ready to give up all for lost! Adding to the embarrassment of the enterprise, the first streaking of the eastern sky with the early dawn was now discovered. The Confederate gunboat was now coming in. The transport *Etiwan* hailed to know if all was ready. Still the great gun was swaying in its sling from side to side, but with the tip of its long muzzle lodged upon the turret, as if resisting to the last its own capture by the enemy.

Not a moment was to be lost. Who would give the order to cut loose the prize? Every one shrank from it. Yet what else remained to be done?

Suddenly, to their relief, there came at this instant a friendly wave from the ocean, swelling landward and lifting the hulk higher than before, lifting the spars and blocks, lifting the muzzle of the gun free from its detaining lodgment, and lifting the hearts of all those waiting men from the depths of painful suspense to joy and satisfaction. They could give no cheers in such close proximity to the enemy, but loud murmurs of glad congratulation passed from one to another. Never did morning dawn upon lighter spirits as they saw themselves free at last to return to the city with their well-earned trophy. The cheers they had been forced to suppress were presently given with a burst as they replied to the garrison of Fort Sumter and the batteries of the harbor, cheering them as they passed in broad daylight on their way to the city.

But little remains to be told concerning the recovery of the *Keokuk's* guns. Practice makes perfect all the world over. In three nights more the second gun was made ready for hoisting; the weather was favorable; the same force of men and means of transportation were employed, and the same success, without any delays or drawbacks, crowned their efforts. In the absence of Adolphus LaCoste, owing to severe sickness incurred from exposure, his brother James had entire charge of the gang on

this last occasion, while Lieutenant Kemper commanded the guardboats.

The papers in Charleston announced on May 6th the complete recovery of the guns. And as the enterprise must have been entered upon soon after Major Harris's visit to the wreck on April 19th, an official date, it is fair to conclude that the work occupied about three weeks. Certainly it was well done, and deserves to be held in remembrance. At the time it was complimented with special mention in the reports of General Beauregard and Brigadier-General Ripley. And it will be only a degenerate race in future years that will let it be forgotten.

In a short while after they were landed in Charleston the guns were again under transportation, this time to be used for the defense of the harbor which they had once been brought to attack. One was mounted on the walls of Fort Sumter at the eastern angle of the barbette battery, continuing there and firing thence until the night of the iron-clad attack, September 1st-2d. This gun was subsequently brought back to the city and placed in Battery Ramsay at White Point Garden, where it remained up to the evacuation. The other was mounted in Battery Bee, Sullivan's Island, took part in the severe action of September 8th, and kept its place there to the last. They were the heaviest guns in the harbor, with the exception of two (English) Blakeley rifles that were of very little account because of the inferiority of their projectiles. These failed generally to take the grooves, and would tumble like nail-kegs, without ever attaining their proper range.

By the skill, daring, and perseverance of a few dauntless men Charleston became possessed of two of the proudest and most formidable trophies of the war. They had been abandoned by the Union Navy, then pronounced irrecoverable by the Confederate Navy, but finally, with great risk and labor, they were raised and turned against their former owners. It is no wonder that Mr. Welles, the Secretary, should have closed one of his despatches to Rear-Admiral DuPont with these words: "The wreck and its important armament ought not to have been abandoned to the rebels, whose sleepless labors appear to have secured them a valuable prize." (*Armored Vessels*, p. 108.)

## AN IMPERFECT BLOCKADE.

Port of Charleston, S. C., April and May, 1863: 15 vessels entered, 21 cleared; 10,003 bales of cotton exported. Total receipts customs = \$138,520.

Collector's Office, } W. F. COLCOCK,  
 CHARLESTON, June 3, 1863. } Collector.  
 (*War Records*, vol. xiv. p. 961.)

## INTERCEPTED SIGNALS.

As early as April 9, 1863, signals from the flagship *New Ironsides* were read by the Confederates on Morris Island. General Beauregard reported the discovery of a key to the Union signals in his despatch of April 13th to the War Department in Richmond. (*War Records*, vol. xiv.) The first advantage taken of the discovery was in preparation for the second assault of Wagner. (*War Records*, vol. xxviii. Pt. ii. p. 207.) It appears from the records that a despatch, probably from General Gillmore to Brigadier-General Seymour, was read by Sergeant Millard of the C. S. Signal Corps on Sullivan's Island July 18, 1863, and, being forwarded to General Beauregard's headquarters, it was at once understood as signifying that an assault on Battery Wagner was in actual preparation.<sup>1</sup> Accordingly an

<sup>1</sup> SULLIVAN'S ISLAND, July 18, 1863, 4.55 P. M.

CAPTAIN W. F. NANCE:

The following message has been intercepted:

"GENERAL S.:

"Keep your infantry under arms; the men must remain in line. The island is filled with stragglers. Send a staff officer to brigade commanders. How large is your supporting column?"

G——,  
 "General."

MILLARD,  
 Sergeant Signal Corps.

SULLIVAN'S ISLAND, July 18, 1863.

COLONEL RHETT:

The following message has just been intercepted from the enemy, to wit:

"An assault is ordered at dusk. Husband your ammunition, so as to deliver a rapid fire the last half hour."

TURNER."

LAWRENCE M. KEITT.

(Repeated by Major O. Blanding to Captain Nance.)

(*War Records*, vol. xxviii. Pt. i. p. 454.)

order was sent immediately to Brigadier-General Ripley to extend notice and have "all practicable preparations made" to repel the assault. Colonel A. Rhett, commanding Fort Sumter, informed the author that he heard and responded to the intelligence by training some fifteen of his barbette guns and mortars on Morris Island, and that they opened promptly and effectively upon the assaulting column over the heads of the garrison in Wagner.

Brigadier-General W. B. Taliaferro, commanding the Confederate troops on Morris Island (July 18th), says that he has no recollection of having ever been notified of this intercepted signal.<sup>1</sup> But it is highly probable that he was, and that in the stir of preparation already begun at Wagner with the close of the day and the slackened bombardment such a notice seemed to him at the time scarcely necessary to put him on his guard.

Again, the attack by troops in small boats on Cumming's Point, Morris Island, on the night of September 5, 1863, was made known beforehand to the Confederates by intercepted signals.

So also the naval assault with small boats on Fort Sumter on the night of September 8th-9th was expected, by reason of the discovery of a signal from Dahlgren's flagship read and reported from the deck of the *Chicora* within Charleston harbor.<sup>2</sup>

"The parts of a signal-book" washed ashore on Morris Island from the wreck of the *Keokuk*, and "picked up on the beach" April 8th by Colonel Graham (*War Records*, vol. xiv. p. 890), had nothing to do with the discovery of the key. The signal-officer to whom this book was referred, T. Pinckney Lowndes of Charleston, informs the author that it was only a code for nautical purposes. The real discovery was made through the ingenuity of Captain Pliny Bryan, A. A. G., who, under orders from General Beauregard, obtained it by a *ruse de guerre* practised successfully upon a prisoner who had been brought in from one of the enemy's advanced signal-stations on the coast. Captain Bryan was from Maryland, an intelligent and zealous officer,

<sup>1</sup> *Philadelphia Times*, November 11, 1882.

<sup>2</sup> *History of the Confederate Navy*, Scharf, p. 700.

who, after much active service, died in 1864. (*Military Operations of Beauregard*, vol. ii. p. 154.)

There were constant difficulties and uncertainties in the reading of the Union despatches by the Confederate signal corps; which fact operated to lessen considerably the advantages of the discovery of the key. At Fort Sumter one of the signal corps, T. Pinckney Lowndes, was the first to read a message of the enemy, and the distinction cost him the arduous, as well as responsible, duty of watching for them without relief for three or four days and nights consecutively.

#### PLANS FOR NAVAL TORPEDO WARFARE.

General Beauregard was anxious to arrange with the naval forces in Charleston harbor a night-attack upon the iron-clad squadron before it left the channel after the fight of the 7th of April. A conference was held between Captain John R. Tucker, Lieutenant W. A. Webb, and himself on the 10th of April, and out of it grew a plan that was to have been tried on the night of the 12th, but which was defeated by the departure of the monitors that day. The plan was to collect "spar-torpedo rowboats" in the rear of Cumming's Point, Morris Island, to coast quietly along the front beach to a point nearest the enemy's position, and then, making a dash, the boats should attack by twos any monitor or ironsides they could discover. The boats, fifteen in number, were made ready under Lieutenant W. H. Parker, but did not leave the harbor.

As the experiments made with these "spar-torpedo rowboats" by Captain F. D. Lee of the Engineers had been highly successful, it must have been very disappointing to the general commanding to have delay prove fatal to his project. Again, the day after the monitors left another plan was urged by the general on Captain Tucker, this time to run down and sink the New Ironsides by a combined attack of the Confederate iron-clads and the spar-torpedo boats. Whether anything came of this project or not the records do not tell. So far as designs on the New Ironsides were concerned, nothing was done by the navy until Lieutenant W. T. Glassell's gallant but ineffectual attempt in October following. (See Appendix B.)

But a flotilla of small boats was maintained for torpedo service. First organized under Lieutenant William A. Webb, C. S. N., as a "special expedition" against the monitors before their arrival off the harbor, it passed into the hands of Lieutenant W. G. Dozier, C. S. N. Under his command, boats for torpedo-service were kept ready all through the ensuing summer, and should be remembered among the many defenses of the harbor of Charleston.

It was out of this flotilla that material was gathered for an expedition with torpedo-boats against some of the monitors lying in North Edisto Entrance, near Rockville, on Wadmalaw Island. It was on May 10th that Captain W. H. Parker, C. S. N., having Lieutenant Glassell for second in command, took through Wappoo Cut into Stono, and down to Edisto, six small torpedo-boats. They were secretly and successfully placed in the best position from which to dash upon the monitors. Everything was in the most favorable train and condition when it was discovered that a deserter had made his way to the enemy's vessels and given them notice of their danger. Nothing remained to be done but to bring the boats back with secrecy to Charleston. And this was effected with the co-operation of Brigadier-General J. Hagood, who, commanding in that district, furnished the expedition with wagons for the overland passage of the boats from Edisto to Stono. (See *Recollections of a Naval Officer*, by Captain William Harwar Parker.)



## CHAPTER IV.

### DESCENT OF THE UNION ARMY ON MORRIS ISLAND—FIRST ASSAULT OF BATTERY WAGNER.

**April 12—July 16, 1863.**

THE DEPARTING MONITORS SALUTED BY FORT SUMTER—THEY ESCAPE ATTACK PREPARED FOR THEM WITH SMALL BOATS CARRYING SPAR-TORPEDOES—WORKING-PARTIES ENGAGED DAY AND NIGHT FILLING CASEMATES ON SEA-FACE OF FORT SUMTER WITH SAND EXCAVATED FROM THE PARADE—FORTIFICATIONS OF MORRIS ISLAND—UNION WORKS SECRETLY CONSTRUCTED ON NORTHERN EXTREMITY OF FOLLY ISLAND—CONFEDERATES SHELL THE WORKING-PARTIES, JUNE 10TH, FROM SOUTHERN END OF MORRIS ISLAND—REDUCTION OF GENERAL BEAUREGARD'S TROOPS AROUND CHARLESTON AGAINST HIS EARNEST REMONSTRANCE—BRIGADIER-GENERAL GILLMORE AND REAR-ADMIRAL DAHLGREN ASSUME COMMAND OF THE UNION FORCES—SMALL FORCE OF ARTILLERY AND INFANTRY ON MORRIS ISLAND UNDER COLONEL GRAHAM—ON JULY 10TH, BRIGADIER-GENERAL STRONG, COMMANDING A COLUMN OF 2000 MEN, FORCES A LANDING ON THE SOUTHERN END OF MORRIS ISLAND, AFTER A HEAVY COMBINED CANONADE (LAND AND NAVAL) FOR SEVERAL HOURS—CONFEDERATES ABANDON THEIR WORKS WITH LOSS, AND FALL BACK UPON BATTERIES WAGNER AND GREGG—ON THE SAME DAY UNION TROOPS DEMONSTRATE IN FORCE ON JAMES ISLAND AND ON THE SAVANNAH RAILROAD BY EXPEDITION UP THE EDISTO RIVER—ON THE MORNING OF JULY 11TH AN ASSAULT ON BATTERY WAGNER REPULSED WITH CONSIDERABLE LOSS—THE CONFEDERATES ENTERTAIN PLANS OF REPELLING THE INVADERS, BUT UPON DISCUSSION IN COUNCIL DECIDE TO MAINTAIN THE DEFENSIVE.

THE departure of the monitors was a subject of sincere rejoicing. As long as they kept their anchorage inside the bar the issue was felt to be undecided, for enough had been done by them on April 7th to create a profound respect, however short of expectation the attack had fallen. As the squadron was seen to depart on the 12th, Fort Sumter's garrison was turned out for dress-parade, the flags were all raised, and a

salute of thirteen guns was fired in honor of the event. The defenders of Charleston harbor received a vote of thanks from the Legislature of South Carolina, then in session at Columbia.

It had become well known in the fort that the injuries received in the late fight were neither great nor numerous. But it was feared that the "iron-clads" might attempt to run the gauntlet by night, or even by day, and so pass the guns they could not silence.<sup>1</sup> The defensive works of Sullivan's Island, and especially those of the inner harbor, were very far from having then the superiority they attained in the next few months. Once past these, the squadron could inflict great injury on the city and destroy some of its communications.

Had two facts been known at this time, the demonstrations of public joy would have been much greater. One of these was the "naval scare" that it was possible to convey by a liberal exhibition of barrel-floats suggestive of torpedoes, obstructions, and *what-nots*, real or unreal, as the case might be. The other was the severity of the damage done to the vessels. It has been shown how the North was long denied full official information, and, as it happened, even the newspaper accounts could reach the South but slowly. When, at length, the truth began to be known, the feeling in Charleston harbor was ani-

<sup>1</sup> Opinion of General Beauregard in the *Philadelphia Weekly Times*:

"It is pertinent for me, professionally, to remark that had the Federal naval attack on Fort Sumter of the 7th of April, 1863, been made at night, while the fleet could have easily approached near enough to see the fort—a large, lofty object covering several acres—the monitors, which were relatively so small and low on the water, could not have been seen from the fort. It would have been impossible, therefore, for the latter to have returned with any accuracy the fire of the fleet; and this plan of attack could have been repeated every night until the walls of the fort should have crumbled under the enormous missiles which made holes two and a half feet deep in the walls and shattered the latter in an alarming manner. I could not then have repaired during the day the damages of the night, and I am confident now, as I was then, that Fort Sumter, if thus attacked, must have been disabled and silenced in a few days. Such a result at that time would have been necessarily followed by the evacuation of Morris and Sullivan's Islands, and soon after of Charleston itself, for I had not yet had time to complete and arm the system of works, including James Island and the inner harbor, which enabled us six months later to bid defiance to Admiral Dahlgren's powerful fleet and Gillmore's strong land-forces."

mated enough, but the glow of it had departed with the first flush of victory.

The work of making Sumter stronger was at once begun. Where the wall of the sea-front had been cracked at some of the embrasures of the lower tier and penetrated at the upper-tier casemates, and especially at the broken parapet about the middle of the barbette battery, a heavy backing of sand, revetted with sandbags, was immediately supplied under direction of the assistant engineer in charge, Edwin J. White. The armament of the same battery was increased by the addition, the very night after the battle, of two 10-inch columbiads in substitution for two 9-inch Dahlgrens, removed to another face of the work. A heavy traverse of sandbags was in place on the same front by the morning of the 9th, and the *terreplein* and arches over the magazines were strengthened by sandbags. To relieve the garrison of so much extra work large details of from one to two hundred men of the Forty-sixth Georgia volunteers were ordered to the post, and rendered valuable assistance in fatigue duty for several days and nights.

Well-considered reports had by this time been made by the engineers as to the damages and the changes proposed for their repair. (See Appendix.) Major Wm. H. Echols reported a full account of the action, and accompanied it with a map and several drawings, among them elevations of the eastern and north-eastern fronts, showing all the shot-marks received in the attack. This was still further made clear by a figured key and description of the several marks. Major D. B. Harris, chief engineer of the Department, also reported, both in conjunction with Major Echols and with Major-General Gustavus W. Smith, acting then on General Beauregard's staff and visiting the fort for inspection. General Smith sent in a brief memorandum to department head-quarters stating, among other things, that "the efficiency of the fort was not impaired by the recent bombardment;" which was strictly true, so far as the fire of the fort was concerned and its readiness to meet another attack the next day with heavier metal than it had already done. Major Harris recommended the filling with sand of all the casemates on the sea-front, both upper and lower; and this was with great labor

effected. His advice that this filling should be extended also to the casemates of the north-eastern face was never carried out: sand was too precious and labor had to be economized; the sequel proved it unnecessary.

All parties agreed upon the importance of protecting the magazines, particularly from the reverse fire of the squadron directed on what might be called the diagonal lines of the fort. It was accordingly ordered that the upper magazines should be at once abandoned, so as to fill over the arches of the lower ones, and that these latter should be further protected by reinforcing walls of brick without, on the gorge, in continuation of the stone masonry already there, and within on the parade, where the ventilators were large and the walls were thinner than elsewhere. These important orders were executed within the next month, and their wisdom was entirely vindicated.

But the greatest difficulty remained in the question how to strengthen the parapet and secure the most valuable guns of the fort, those *en barbette*. Sand could do much for the casemates, but neither sand nor anything else could be put on the interior of the parapet without sacrificing the best guns. An experiment was made of suspending compressed bales of cotton, saturated with water, over the exterior of the parapet by ropes and eye-bolts let into the masonry. It was expected that a bale would be easily displaced by a shot, but there was hope that much of the severity of the blow would be relieved before the brickwork could be reached, and the displaced bales could then be easily renewed. The essay proved a failure; for the cotton, rapidly drying in the ripped and exposed parts of the bale, caught fire from the blast of the guns fired over it.<sup>1</sup> The bales were all removed, and shortly after used for filling in the officers' quarters on the gorge, where, laid wet in sand, they did invaluable service by their bulk and resistance.

<sup>1</sup> A better plan, suggested by General Beauregard, but never carried out, would have been to use compressed bales of green moss (*Tillandsia usneoides*), the long, trailing moss so common on the coast of the South Atlantic. Gunboats in running past the batteries of the Western rivers, particularly at Vicksburg, found protection from hanging logs and even bales of wet hay over their sides, as chains also have often been employed for the same purpose.

Meanwhile, the greatest activity prevailed at the fort. The engineers kept a force of one hundred and thirty blacks, together with a gang of white mechanics and some details from the garrison, busily employed in unloading materials and various works of construction. The particular duties of the garrison, however, were with their own offensive preparations. The batteries, under the direction of their skilled artillerymen, Brigadier-General Ripley and Colonel Rhett, were put in the finest condition, and arranged so as to deliver at each point a fire of maximum efficiency. But except one of the XI-inch guns recovered from the wreck of the Keokuk, Fort Sumter could not find, in all the Confederacy, any metal heavier than that used for its defense on the 7th of April.

During this period the fort was frequently visited by officers on leave, by citizens, and even ladies, to see the scars of the late fight, or, in the midst of bustling preparations, to admire the regularity of the batteries and the perfection of the drill. But the area of the parade, so long kept in faultless order, was now quite broken up and tumbled with the pits and diggings of the working-parties or encumbered by plankways and wheelbarrows. From this parade, as from a treasury, was procured the sand used in filling the casemates and covering the magazines, until, more than four feet of depth having been excavated, it was found necessary to bring the material by night, bagged or loose, in flats towed from the city.

Before long twelve lower and thirteen upper casemates on the sea-front had been filled with sand, retained both outwardly adjoining the scarp, and on the rear toward the interior of the fort, by a sloping *revêtement* of sandbags coated with coal-tar. It will aid in appreciating the magnitude of this work to bear in mind that the casemates of the lower tier were arched chambers each ten feet ten inches high, and those of the upper tier much larger, being three feet higher. Brick masonry also was pressed at this time to complete the protection of the magazines on both the exterior of the gorge and on the side of the parade within the fort. A start was made with several courses of heavy timber to construct a grillage or cribwork, to be filled with stone ballast, on the berme of the sea-front. Here, as on four sides of the fort, the enrockment at high-water mark afforded a

level base of ten feet for the erection of what would have helped materially to protect the lower casemates, already closed and filled. But this work was never raised higher than five feet along the berme of the sea-front; then the timber, being needed, was removed for other and more important purposes within the fort. A heavy, continuous battering from land-guns, such as the fort afterward suffered, would have made short work of the grillage; but no attack of such kind was then apprehended: preparations were made only against another attack from the armored vessels.

The proximity of Morris Island could never have given any concern to the military board charged with the original planning of Fort Sumter. The principle then (1829) must have been—the fort commands the island; and even after the developments at Fort Pulaski<sup>1</sup> in Georgia, in the spring of 1862, it must have been hard to entirely eradicate the principle from the minds of the old school. It was now about to be greatly modified, and, in the sequel, entirely reversed.

Cumming's Point of Morris Island had for some time been occupied by a substantial sand-battery, designed as an outwork of Sumter, to protect its gorge from a fire coming from the main ship-channel, as well as from the land side of Morris Island and the creeks between Morris and James Islands. It carried two heavy guns of 9- and 10-inch calibre and some lighter ones. This work was "Battery Gregg." Its distance from Sumter was 1390 yards. From this point the island, a mere strip of low sandy hillocks, continues flat, narrow, and open to view for one half its entire length of nearly four miles. The southern half widens, and rises in sandhills of from thirty to forty feet above tide. Within the range of Fort Sumter's guns, 2780 yards distant, and located immediately to command the narrowest part of the island, "Battery Wagner" extended across from one water's edge to the other, with a front of 250 yards, and was destined to play a prominent historical part of its own as the principal advanced work of Fort Sumter.

Originally selected by order of Brigadier-General R. S. Ripley, the site of this work was afterward shifted and its

<sup>1</sup> Breached at a distance of 1650 yards after twelve hours' firing.

dimensions greatly increased.<sup>1</sup> The occasion of this remodelling was the evacuation of Cole's Island by the Confederates in the spring of 1862, by order of Major-General J. C. Pemberton, then commanding the department. The opening of such a favorable base for the enemy to operate from in Stono, either against Morris Island or James Island, directly adjacent to Charleston, was warmly opposed by Brigadier-General Ripley, commanding the First Military District, and severely condemned by public opinion at the time. General Pemberton, however, proceeded to order the enlargement of Battery Wagner on Morris Island and the building of Battery Bee on Sullivan's Island, two of the most prominent works in the future defense of the harbor.

"Battery Wagner," as it was always known to the Confederates, came to be called by the Federals a "fort" after its reputation had been made by its stubborn resistance.<sup>2</sup> While its chief purpose was to keep an enemy approaching from the southern end of Morris Island beyond breaching-distance of Fort Sumter, its exposure to a heavy naval fire on its left flank required its two fronts to be so planned as to protect each other. Additional improvements were ordered by General Beauregard. Two or three heavy guns were now placed on the channel side and from ten to twelve lighter ones on the land side. A well-protected magazine, heavy traverses, and a bomb-proof thirty by one hundred and thirty feet completed the defensive arrangements. The gorge was closed with a parapet for infantry fire. Morris Island, thus covered by the guns of Sumter, Gregg, and Wagner as far to the southward as the middle region of its extent, needed further protection for its southern extremity.

In abandoning operations after the repulse of the 7th of April

<sup>1</sup> From a point about a hundred yards in advance of this work the first hostile shots in the war had been fired at the steamer *Star of the West*, preventing her from supplying Fort Sumter, January 9, 1861.

<sup>2</sup> General Beauregard, in reporting to Richmond, September 30, 1863, says: "Battery Wagner was not 'a work of the most formidable kind,' but an ordinary field-work with thick parapets, but with ditches of little depth." General Gillmore contended always that it was "formidable," on account of its approaches as well as its plan and armament.

the Federals had continued to occupy and control, from Stono Inlet, the whole of Folly Island next south of Morris Island. A force of about 5000 men under Brigadier-General I. Vodges had constructed strong works upon it "at the south end and about two miles from the north end," and a military road ten miles long communicated with all parts of the island. The position was a strategic one of the highest importance. A naval force of two gunboats and a mortar-schooner, stationed in Stono Inlet and Folly River, co-operated directly with the brigade. The northern extremity of Folly, subject to being cut off by tidal overflow, became known as Little Folly Island. Here the Federal pickets watched the Confederates, separated by Lighthouse Inlet, some five hundred yards wide.

As early as the 10th of March, some weeks prior to the attack of the iron-clad squadron on Fort Sumter, General Beauregard ordered the southern end of Morris Island to be fortified. This was, therefore, before the occupation of Folly Island by the enemy. Brigadier-General Ripley reminds the commanding officer (May 24th) that although "there are now seven guns, of which four command the crossing at Lighthouse Inlet, they are all badly prepared for service." Thinking to improve the situation, Ripley acts for himself (June 1st), and puts Captain John C. Mitchel of the First South Carolina Artillery in charge of construction.<sup>1</sup>

Some of the works were then completed, so that Mitchel opened on Folly Island on the 12th of June, and continued to fire in a desultory way while the Federals, making no reply, but working like beavers, after the 14th of June were secretly constructing batteries for forty-seven guns and mortars within less than a thousand yards. General Gillmore testified: "For about a week the enemy kept up a brisk fire upon the place where we were working. The firing was principally from mortars, and

<sup>1</sup> By this action the engineer in charge, Langdon Cheves, was displaced. His letter to the chief engineer resents the charges of dilatory preparation, and corrects the "inaccuracies and implications" of General Ripley's correspondence. (See letters of the chief engineer and Mr. Cheves in *War Records*, vol. xxviii. Pt. ii. pp. 178-180; also the chief engineer's mention of the labor question in Appendix, ch. iv.)



was very accurate.”<sup>1</sup> Colonel Davis adds: “It killed and wounded several men.”

It may well be asked, Why was not this fire of the Confederates more vigorously maintained? Only their confidence that nothing serious was meant by the Federals can account for the oversight, while it cannot excuse it. With lookout stations on the ruins of the old lighthouse, Morris Island, on the masthead of a wrecked blockade-runner, Ruby, off Lighthouse Inlet, and at Secessionville on James Island, there was yet no discovery of these Federal works. So far from it, that Brigadier-General Ripley reports, August 29th, that “up to the 8th or 9th of July the enemy, so far as ascertained, had constructed no works on Little Folly, except to shelter his pickets from our shells.” This was a day or two only before the attack, and those thoroughly well-built batteries for forty-seven guns and mortars had been under construction *since the 14th of June* without any discovery. The defensive batteries on Folly Island, two miles south of these, were known to the Confederates, being visible from Secessionville.

On the southern end of Morris Island were only eleven guns and mortars<sup>2</sup> in detached batteries, with no connecting lines, but only rifle-pits to dispute the passage of the inlet and oppose the descent on the island. Some of the rifle-pits were advanced to cover Oyster Point on the right: most of them were behind the batteries.

But it was in respect of troops more than of anything else that the Confederates were deficient. The works may not have been completed, but they had been maintaining a desultory fire

<sup>1</sup> General Vodges reports “that a dense copse-wood near the north end” afforded concealment to the working-parties. Low sandhills also contributed to the same end. But it was chiefly to a ruse practised on the artillerists of Morris Island that the concealment was due. A blockade-running steamer grounded and became a wreck off the inlet. When General Vodges advanced a few field-guns on the beach to shell the wreck, the Confederate batteries drove them off, and thenceforward, their men being unmolested in plundering the cargo, the impression was conveyed to the Confederates that only a picket force was opposed to them.

<sup>2</sup> Three 8-inch navy shell-guns, two 8-inch sea-coast howitzers, one rifled 24-pounder, one 30-pounder Parrott rifle, one 12-pounder Whitworth, and three 10-inch sea-coast mortars.

for nearly four weeks, quite enough, as reported, to disturb the working-parties of the enemy. To explain this lack of infantry supports in particular, it must be recorded that the forces under General Beauregard had been reduced by requisition of the War Department in Richmond, notwithstanding his protest, from a total, on the 7th of April, 1863, of 30,040 to a total, on the 10th of July, 1863, of 15,318. "Thus," he says, "on the 10th of July, 1863, I had but 5861 men of all arms in the First Military District guarding the fortifications around Charleston." (*Military Operations of General G. T. Beauregard*, vol. ii. p. 109).

And in perfect accord with the above is Brigadier-General Ripley's answer to the eighth question in the same volume (Appendix to chapter xxxiii.): "My force of infantry was, in all, 2462 effective—1184 on James Island, 612 on Morris Island, 204 on Sullivan's Island, and 462 in Charleston." Against this depletion of his forces General Beauregard had earnestly remonstrated, informing the authorities at Richmond in May, June, and July of the imminent risk of being found unprepared for attack.<sup>1</sup> Under date of June 15th he writes: "The garrison of no work in the harbor can be withdrawn or diminished, as they are all necessary links in the chain of defenses. Reduce the command on James Island, and the enemy may readily penetrate by such a *coup-de-main* as was attempted last year at the weakened point. James Island would then fall, and

<sup>1</sup> "I must respectfully ask your attention to the paper herewith, marked A, exhibiting the force of all arms that will be left me after the execution of your orders, and that in the department this time last year.

"You will perceive that I shall be left with 12,664 men of all arms less than at the same period last year, and when the force of the enemy was less threatening in its position than now; that my infantry force for the support of the lines around Charleston will be but 1547, whereas last year the infantry force for the same duty was 6462, leaving the lines on James Island virtually without infantry support, and open to seizure and the inevitable fall of Charleston." (G. T. Beauregard, May 11, 1863, to the Secretary of War.) This date was only two months prior to the descent of General Gillmore on Morris Island: the expostulation, a full and very earnest one, was in reply to Mr. Seddon's demand for 5000 more troops for the West, under the gross misapprehension that a reduction of Union forces threatening Charleston had been made. (See *War Records*, vol. xiv. page 931.)

*despite our harbor defenses, the city of Charleston would be thrown open to bombardment.*" (*Military Operations*, vol. ii. page 109.)

It will appear in the end that this view was entirely justified. For not only was James Island menaced by the landing of 3800 men with a naval support at the time of the descent on Morris Island, but it is plain that if the column of 10,000 effective Federals had been thrown upon the centre of the attenuated lines of James Island with anything like the dash of the assaults on Morris Island, they would have pushed through to the shores of the inner harbor and compelled the surrender or evacuation of the city.<sup>1</sup>

But to resume the train of events. It must be noted what changes had, about this time, been made in the Union forces. On the 12th of June, 1863, Brigadier-General Q. A. Gillmore relieved Major-General D. Hunter in the command of the Department of the South. On the 6th of July, 1863, Rear-Admiral John A. Dahlgren relieved Rear-Admiral Samuel F. DuPont. Thus a complete change in the command of the United States forces occurred within two or three months after the repulse of the iron-clad squadron. It has been mentioned that Brigadier-General Vodges occupied Folly Island, and, co-operating with him, the navy held Stono Inlet and River. This inlet, by air-line from Charleston only ten miles, was by water on the interior line sixteen miles, and by the exterior or sea-shore line nineteen miles, from the city. The Union commander decided to make this his base, and concentrated here a force of 10,000 infantry, 350 artillery, and 600 engineer troops, forming a total of nearly eleven thousand men, for a descent from Folly Island upon the southern end of Morris Island, with the design of advancing on Fort Sumter for its reduction, with the closest possible co-operation of the navy. The highest praise is due to the secrecy, despatch, and ability

<sup>1</sup> See *Military Operations of General Beauregard*, vol. ii. page 114, report of September 18, 1864. Also Brigadier-General R. S. Ripley's replies to questions, etc., *ib.*, vol. ii., Appendix to chapter xxxiii., particularly page 524, where he says: "I consider it fortunate, under all circumstances, that, situated as we were, the enemy chose the Morris Island route."

which characterized all these preliminary movements.<sup>1</sup> Against the detached and unfinished works of the Confederates there were in place, by the 10th of July, forty-seven guns and mortars; nearly 2000 men of General G. C. Strong's brigade, with 1000 more in reserve, ready in boats to cross the inlet; four naval launches armed with howitzers to cover the landing; and four monitors in the channel ready to take part as soon as the attacking batteries on Folly Island should be opened. Reinforcements were also in easy reach.

The Confederate force on Morris Island at this time was disposed as follows: At the southern end were two companies and a detachment of the First South Carolina Artillery (200 men)—Co. I, Captain John C. Mitchel, Lieutenants John S. Bee and J. Guérard Heyward; Co. E, Captain J. Ravenel Macbeth, Lieutenants J. Julius Alston and K. Kemper, with Lieutenant H. W. Frost of Co. H, supported by about 400 men of the Twenty-first South Carolina volunteers, Major G. W. McIver commanding, and by a detachment of fifty men from the First South Carolina Infantry under Captain Charles T. Haskell, Jr.—making a force at this point of less than 700 men. Battery Wagner was garrisoned by two artillery companies—Gist Guards, Captain C. E. Chichester commanding, Lieutenants R. C. Gilchrist, Theodore G. Boag, and A. C. Whitridge; Mathewes Artillery, Captain John Raven Mathewes, Lieutenants S. Hall and Gillon. Battery Gregg was garrisoned by a company of the First South Carolina Artillery, Captain Henry R. Lesesne commanding. Lieutenant-Colonel J. A. Yates, First South Carolina Artillery, was chief of artillery, and Colonel R. F. Graham, of the Twenty-first South Carolina volunteers, was in command of the island, the total force being 927 men.

On James Island, the total force was 2906; on Sullivan's Island, 1158; in Charleston proper, 850—thus making a total of all arms in and around the city of 5841.

The Union batteries on Little Folly Island were reported ready for attack on the 6th of July, and orders were issued by

<sup>1</sup>The preparing of these masked batteries was entrusted to Lieutenants Charles R. Suter and P. S. Michie of the Engineers, and to Captain A. Mordecai of the Ordnance Department.

Brigadier-General Gillmore, commanding, to open fire and advance on the night of the 8th, barges being collected for the purpose; but no attack was made at that time. It was on this night of the 8th-9th that Captain Charles T. Haskell, Jr., scouting from Morris Island in a small boat, made discovery of the barges moored in the creek back of Folly Island. Even this discovery failed to alarm the defenders of Morris Island, as it should have done; for Brigadier-General Ripley, as already mentioned, reported none but light defensive works across the inlet "up to the 8th or 9th of July."

Another time set for the attack was the morning of the 9th, but bad weather and other unfavorable circumstances caused a second postponement. Some cutting away of brushwood from the front of the concealed works had already been heard by the Confederates, but as there was no removal of the brush, the batteries continued to be undiscovered up to the last moment.

On this day, however, the 9th, a division of troops, supported by gunboats, began the movements, demonstrating on James Island by way of the Stono River, and an expedition set out from Beaufort to cut the Savannah Railroad at the Edisto. Of these more will be said farther on.

Soon after daybreak, about five o'clock, on the 10th day of July, a close, sultry morning, the batteries were finally unmasked and opened upon Morris Island. Some attack was looked for by the Confederates, but not such a furious and overwhelming cannonade as now began and continued for three hours. It was made with more than four times their number of guns and troops. Forty-seven guns and mortars were afterward, in an hour's time, joined by eight more guns of the heaviest calibre from the monitors, assisting with their formidable cross-fire. The land-attack was commanded by Brigadier-General T. Seymour.

The reply of the Confederate batteries was not immediate, as they were taken much by surprise; nor was it effective against such odds. Guns were disabled and casualties were very frequent. The infantry supports occupied the main line of rifle-pits to the rear of the works, with only a picket-guard at Oyster Point. But when the troops of Strong's brigade appeared in boats coming from the cover of Folly Island into the inlet and

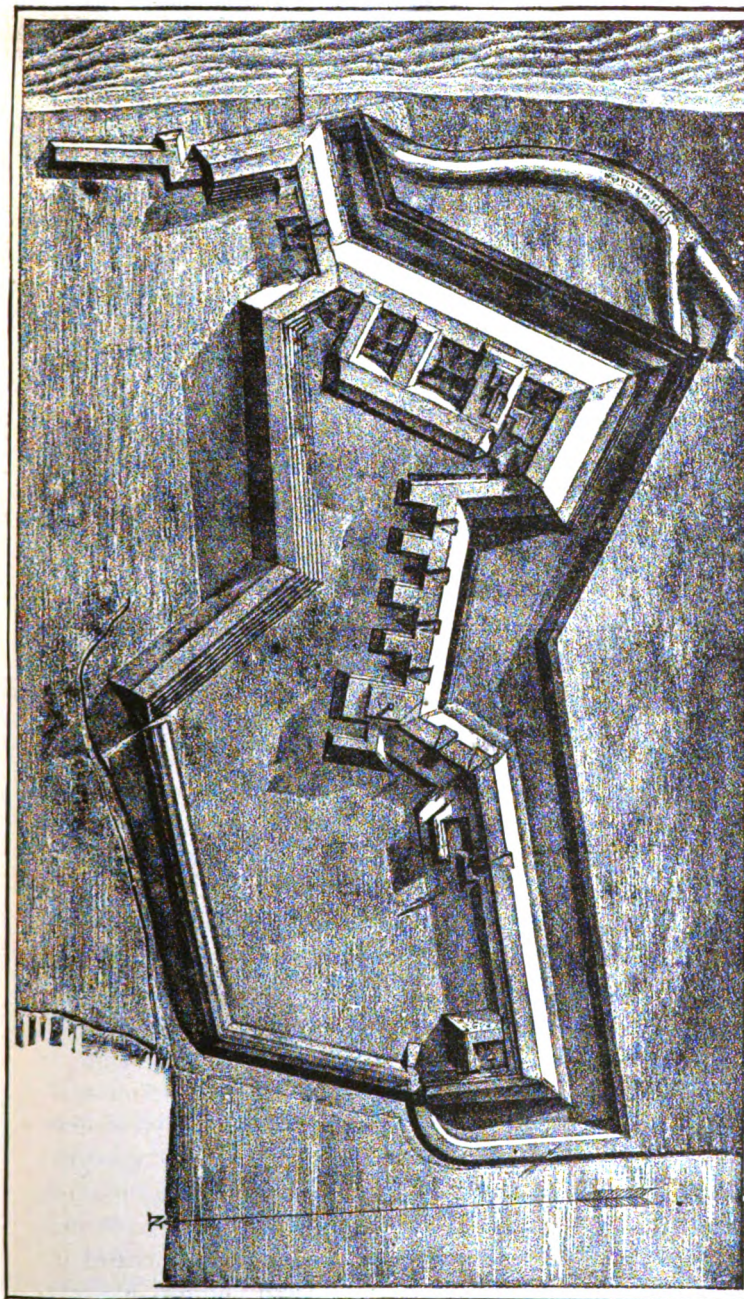

**BATTERY WAGNER.**  
(Diminished from the plan in General Gillmore's Report, 1865.)

advancing on Morris Island, the Confederate batteries were put to better use than before, firing upon the flotilla and sinking a launch; then the infantry, under Major G. W. McIver, moved forward to meet the attack by occupying the advanced rifle-pits near the water. This was about seven o'clock.

On came the boats, using their howitzers and aided by a fire from the left of the Folly Island batteries specially directed by the officer in command, Lieutenant-Colonel R. H. Jackson, upon the infantry forming to dispute the landing. One division of the boats, led by four companies of the Seventh Connecticut, under Lieutenant-Colonel D. C. Rodman, made gallantly for Oyster Point, and carried, after a short resistance, the rifle-pits in that vicinity. Another division, with the Sixth Connecticut, Colonel J. L. Chatfield commanding, kept on down the inlet to the south-eastern point of the island, where it landed under cover of high ground in perfect safety, as the Confederate guns could not be depressed sufficiently to bear on the spot. (Lieutenant-Colonel L. Meeker's report.) With a charge from this point, and but little loss, the Sixth Connecticut captured the nearest batteries, while, converging toward the middle of the island, the other (the main) column, led by the Seventh Connecticut and comprising also the Forty-eighth New York, Ninth Maine, Third New Hampshire, and Seventy-sixth Pennsylvania, took battery after battery, and drove the infantry support out of their main line of rifle-pits in full retreat up the sandy length of the island toward Fort Wagner.

The Confederates fought their batteries as long as they could under Captain Mitchel and Captain Macbeth, the latter being wounded and captured; but the extreme heat of the day, combined with the overpowering fire of the enemy's guns, told disastrously on the small force both of artillery and infantry, so that Colonel Graham could do nothing but give the order to retreat. 150 wounded or exhausted men, with Captain Macbeth and Lieutenants Bee and Guérard, were made prisoners, the total loss, killed, wounded, and missing, being reported by General Ripley at 294. Among the killed or mortally wounded were Captain Charles T. Haskell, Jr., First South Carolina Infantry, Lieutenant John S. Bee, First South Carolina Artillery,

Lieutenant T. H. Dalrymple, Twenty-first South Carolina volunteers, and Assistant Engineer Langdon Cheves.<sup>1</sup> The Union loss was 107, Captain L. H. Lent, of the Forty-eighth New York volunteers, being among the killed.

The retreat of the Confederates over the heavy sand toward Fort Wagner, nearly three miles of toilsome effort under a broiling sun, was at length covered by that work and the arrival of seven companies from Lieutenant-Colonel P. H. Nelson's Seventh battalion of South Carolina volunteers,<sup>2</sup> under Major James H. Rion; the retreat being followed up by the four monitors, close in to the beach, as far as Wagner itself.

The part taken by the monitors in this day's operations was highly important. Rear-Admiral Dahlgren, having his flag on the Catskill, reports that they reached Wagner by 9.30 A. M., and that 534 shell and shrapnel were thrown upon the island by their XI-inch and XV-inch guns that day. The Folly Island batteries reported 2500, making a total of 3034 for the cannonade. The Catskill, flagship, was particularly noticed by the

<sup>1</sup> Captain Haskell was one of several brothers who highly distinguished themselves in the war. His own services around Charleston harbor were active, gallant, and valuable. He fell in the rifle-pit while standing and encouraging his men. His last words to a comrade (Captain James W. Owens, Twenty-first South Carolina volunteers), to whom he extended his hand, were: "Tell my mother that I died for her and my country."

First Lieutenant John S. Bee had shared in Fort Sumter, on April 7th, the honors of that day. He fell in the discharge of duty well done, and few officers were more missed or lamented.

Langdon Cheves, whose intelligence and capabilities amply qualified him for the rank of captain of Engineers accorded him by courtesy, had become identified with the building and perfecting of Battery Wagner. Captain F. D. Lee applied for him as his assistant and always esteemed him very highly. Being on duty in Wagner, he had just been informed of the death of his nephew, Captain Haskell, and, though feeling it deeply, "he roused himself to action as the sound of approaching battle grew louder, and, stepping across the threshold of his door toward one of the magazines, he was stricken to death by a fragment of the first shell hurled at Fort Wagner." (*Charleston Year-Book, 1884.*) Langdon Cheves was the son, and bore the name, of Judge Cheves, who was also a Speaker of the House in Congress from South Carolina.

<sup>2</sup> Lieutenant-Colonel P. H. Nelson, of Sumter county, South Carolina, served gallantly through the war, until killed in a sortie before Petersburg, Va., June 24, 1864.



artillerists of Wagner and Gregg, having been struck sixty times, or, to quote, "severely handled, their 10-inch smooth-bores doing us the most harm, the rifles generally glancing or striking sideways." (Report of George W. Rodgers, commander.)

Major-General Gillmore had now, by nine o'clock, gained with his troops three-fourths of Morris Island, and after an engagement lasting three hours and a quarter the Federal troops had been pushed forward within range of Wagner. But, falling back, probably to their defensive line, some fourteen hundred yards distant, they spent the night there, under orders to assault early next morning. The Confederates, reinforced after midnight by a fine body of Georgia troops,<sup>1</sup> made ready for them with a total force (at Wagner) of about one thousand infantry and two hundred artillerists.

From the parapet of Fort Sumter the attack had been clearly seen. The island being, for the most part, perfectly bare and open to the view, every stage of the operations except the crossing of the inlet had been watched with the keenest interest. When at length, about 10 A. M., a Federal flag raised on the Beacon-House, some 4000 yards distant, told of the enemy's position, Colonel Rhett ordered one of his favorite Brooke rifles to open from the south-eastern angle. Thus began the firing of the fort in protection of its outposts. It was continued for several days with two 7-inch Brooke rifles and two 32-pounders rifled and banded;<sup>2</sup> afterward with columbiads and 10-inch seacoast mor-

<sup>1</sup> These were four companies each from the First Georgia regiment, Colonel C. H. Olmstead, and the Twelfth Georgia battalion, Lieutenant-Colonel H. D. Capers, and three companies from the "Savannah Volunteer Guards," known as the Eighteenth Georgia battalion, under Major W. S. Basinger, amounting to about 534 men. The Seventh South Carolina battalion, under Major James H. Rion, numbered about 300 men.

Among the troops in the battle on Morris Island from Savannah were a portion of the First regiment Georgia volunteers—viz. German Volunteers, Captain Werner; Oglethorpe Light Infantry, Company B, Lieutenant James Lacklison; the Washington Volunteers, Captain John Cooper; and the Tatnall Guards, Captain A. C. Davenport.

<sup>2</sup> The firing of these guns being very satisfactory for that time, the following particulars are subjoined: The rifled and banded 32s had been smooth-bores, taken from the casemates and transformed at Eason's workshops in the

tars by day and night for weeks, until the fort itself was under fire from the breaching-batteries at an extreme range that defied all reply. Major-General Gillmore testifies regarding this fire, particularly during the assaults of 11th and 18th of July, that it was both "accurate and destructive." From returns it is estimated that over one thousand projectiles of all kinds were thus thrown by Fort Sumter upon Morris Island.

At the dawn of day, July 11th, the first assault on Battery Wagner was made by the Union force. As witnessed from the walls of Fort Sumter, it appeared short and sharp, lasting less than a half hour and ending in a complete repulse. The attacking column, commanded by Brigadier-General G. C. Strong, consisted of troops from the Seventh Connecticut (four companies), the Seventy-sixth Pennsylvania, and the Ninth Maine regiments, while two regiments from New Hampshire formed the reserve. The Confederate pickets, about one hundred and fifty strong, under Major James H. Rion, gave them several volleys before falling back to the battery.<sup>1</sup>

city. They were mounted *en barbette* on the gorge, and fired at 14° elevation with a charge of 7½ lbs., a 25" shell, and an effective range of 4800 yards. The 7-inch Brooke rifles, mounted *en barbette*, one at the south-eastern angle, the other at the northern angle of the fort, therefore firing in reverse, were given 20° elevation, 15 lbs. of powder, 30" to 34" shells, and were seen to be effective at a range of 6160 yards, or three and a half miles. On the fifth day of firing the Brooke rifle at the south-eastern angle showed a fracture in the breech on the line of the ratchet-marks, but the banding held the ruined gun together. A shell from the other gun prematurely exploded over the parade and killed one of the garrison on the eastern terreplein. A Federal drummer-boy, writing for the *Philadelphia Times*, records his reminiscences of the firing, as follows:

"They had one barbette gun on the south-east corner of Fort Sumter whose range covered the whole island. Many were the imprecations given it by the poor tired fellows whose rest would be rudely broken by a shell from that gun bursting near or over them. But one night we saw it flash; the shell exploded far short of the usual distance, and as none ever reached us again, we judged that the gun had burst."

General W. W. H. Davis also testifies to the range of this rifle, saying that he saw a shell which had fallen within "a half mile of the inlet." (See *History of One Hundred and Fourth Pennsylvania Regiment.*)

<sup>1</sup> Brigadier-General T. Seymour reports that one chief cause of the failure of the assault was the driving in of the Confederate pickets a whole hour before the advance was made. (See *Appendix.*) This can only be a mistake,

Then, in the lead, the men from Connecticut came on with a dash, headed by the intrepid Lieutenant-Colonel D. C. Rodman. Their place was on the right, advancing in column on the beach, while the other troops marched in line over the undulating sandy soil of the low island. Soon the front became narrowed almost to the beach itself by the marshy ground connected with the creek on the left. This gave to the Connecticut troops the prominence they took and maintained in the short attack, for they found themselves in front of the chief salient and left flanking curtain of the work.

Here and toward the left centre had been placed the infantry from Georgia, Colonel C. H. Olmstead's command on parts of the sea-face and in the left flanking curtain, with Lieutenant R. C. Gilchrist at the guns; Major W. S. Basinger's Savannah Volunteer Guards in the salient itself, with Lieutenant T. G. Boag over his artillery; while the Twenty-first South Carolina volunteers in the centre, the Twelfth Georgia, and the Seventh South Carolina battalion on the right, interspersed with artillerists under Captains Mitchel and Mathewes, completed the dispositions made by Colonel Graham, the commander.

There was not light enough yet for Major Basinger in the salient to distinguish the attacking troops until they had come within less than a hundred yards. He then gave the order to fire. The riflemen of his command were thus the first to open fire and check the assault with a compact, withering volley. Shortly after Lieutenant Boag opened with grape and caister from the salient, and then the fire of both artillery and infantry from all the parapets of Wagner became general. Some of the Connecticut men pushed forward along the beach, passing the salient and sea-face, until confronted by the defenders of the extreme left. A few gained the parapet in this quarter of the fort, hiding afterward in the close gun-pits of the sea-face. From one of these a party of eight or ten was subse-

for, though the pickets did their part well, it is the testimony of Major Basinger and his adjutant that not more than twenty minutes intervened between the first shot heard by him in the salient and the order given by himself to open fire on the assaulting column.

quently taken, being captured there by Lieutenant G. D. Smith of the Eighteenth Georgia battalion.<sup>1</sup>

But the struggle was vain, for when the firing began the Pennsylvanians were ordered to lie down, and did not get into action in time to support their comrades in the advance. They attempted to assault on the centre and right of the battery, but this was done with little spirit, and only this futile effort was made to regain what was lost. Soon, with the advantage of daylight, the heavy fire of the defense cut off quite effectually all support from those who had crossed the ditch and were clinging for protection to the exterior slope of the parapet. These could do no more than surrender when the demand was made on them.<sup>2</sup> The prisoners numbered 130. The total of casualties and captures reported by Brigadier-General Strong for the two days, 10th and 11th of July, was 436, of which number 330 were directly referred to the assault. The Seventh Connecticut lost 104 out of 196, its gallant leader, Lieutenant-Colonel Rodman, having been severely wounded. The Confederates suffered small loss, only 12 casualties, mostly in the Eighteenth Georgia battalion, occupying the salient—a post of

<sup>1</sup> Colonel Olmstead related in an address delivered in 1879 the following incident of this period of the assault, and Lieutenant (afterward Major) Gilchrist confirms it. Colonel Olmstead said: "One brave fellow I saw, however, who had not the thought of yielding in him. Alone he reached the top of the parapet immediately in front of a 32-pounder double charged with grape-shot. The officer in command (Lieutenant Gilchrist of South Carolina, if my memory serves me), struck by his bearing, called to him to come in before the gun was fired. His only reply was to put his musket to his shoulder, and a bullet whizzed by Gilchrist's head. The explosion of the gun followed, and a blue mangled body, all that remained of a brave man and a good soldier, was hurled across the ditch."

<sup>2</sup> Colonel Olmstead again furnishes a reminiscence, as follows: "Immediately after the action a singular instance of the ups and downs and uncertainties of warfare was brought to our attention. Among the first troops to enter Fort Pulaski at its capture in the previous year was the Seventh Connecticut regiment, then commanded by Colonel Alfred H. Terry (subsequently major-general.) Both officers and men had behaved toward us with great kindness during the few days that we remained at the fort after its capture, and we had become personally acquainted with them. Now, we were the victors, and among the prisoners brought in at our end of the line were many of our old friends of the Seventh Connecticut, who recognized and called us by name."

honor which could not have been more vigilantly or bravely defended. The First Georgia regiment lost Captain C. Werner, and Lieutenant Frederick Tupper of the Eighteenth Georgia battalion was severely wounded.<sup>1</sup>

At other points distant from Morris Island two feints or demonstrations had been planned by Major-General Gillmore in combination with the real attack of the 10th of July. One, upon James Island, he says, accomplished successfully its purpose. The other, designed to cut the Charleston and Savannah Railroad, operated from Beaufort up the South Edisto and signally failed.

The demonstration on James Island was with Brigadier-General A. H. Terry's command of about 3800 men, convoyed up the Stono by a naval force of six vessels under Commander G. B. Balch. This officer reported troops landed on the 9th in the afternoon. Colonel C. H. Simonton, commanding on the island, reported their presence next day. On the 11th there was some firing between the gunboats and the Confederate light batteries, followed in the afternoon by an advance of General Terry's troops up to Grimball's Place. The command of the island, with less than 3000 men, passed into the hands of Brigadier-General Johnson Hagood on the 12th, and he was reinforced by two regiments from Georgia under Brigadier-General A. H. Colquitt, and by the Eighth, Thirty-first, and Sixty-first regiments of North Carolina volunteers, under Brigadier-General T. L. Clingman.

On the morning of the 16th the Pawnee<sup>2</sup> sloop of war and the Marblehead gunboat (4 guns) were driven from their an-

<sup>1</sup> THE WORK OF AN OLD SHOE-HEEL.—The author has been told by Mr. Philip G. Langley, who was in the fight, that when he was detailed from his command, the Twelfth Georgia battalion, to bury the enemy's dead in front of the battery, a soldier, mortally wounded, asked him the strange question: "What have you been firing? Haven't you any powder and shot?" On being answered that there could be no doubt of that, the man held up an old shoe-heel, saying, "This was fired at me with your canister, and this has killed me!" He had drawn it out of the wound, and he died soon after.

<sup>2</sup> This particularly annoying, because ever-active vessel, was armed with eight IX-inch Dahlgrens (smoothbore) and one Parrott rifle, 100-pounder, with another lighter gun (smoothbore), 50-pounder. She was struck fifty times in this action, but only suffered four casualties.



Brevet Major-General Q. A. GILLMORE, U. S. A.,  
Commanding Department of the South.

From a Photograph.

Entered U. S. Mil. Acad. from Ohio—Graduated 1849—Capt. of Engineers  
Aug. 6, 1861—Brigadier-General U. S. Vols. April 28, 1862.  
Major-General U. S. Vols. July 10, 1863—Brevet Brig. Genl. U. S. A.  
March 13, 1865—Brevet Major-General U. S. A. March 13, 1865.  
Died 1888.

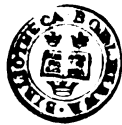

chorage near Grimball's by the sharp and accurate firing of two sections of field-guns from Blake's and Wheaton's (Chatham) batteries, put in position over night by Lieutenant-Colonel Del. Kemper. But in taking a new position lower down the river the vessels were able to render valuable assistance to Brigadier-General Terry, who had been at the same time attacked by Brigadier-General Hagood with two columns of infantry and Parker's light battery, and forced back until the assistance came. Finding the enemy completely under cover of the gunboats, the Confederate troops were withdrawn again to Secessionville. The losses were—Union, 50; Confederate, 18. The Union troops were embarked that night, and left the island for other parts next morning.<sup>1</sup>

The demonstration upon the Charleston and Savannah Railroad was made on the 10th of July. A regiment of newly-enlisted colored troops, under Colonel T. W. Higginson, was sent up the South Edisto to strike the railroad in the vicinity of Jacksonboro'. The expedition, consisting of an armed steamer and two smaller boats, set out from Beaufort, ascended the river, and landed at Willtown, surprising in a fog the small force at that point, but failing to capture it. A delay of some hours there, for plundering purposes, cost them heavily; for time was given, higher up the river, to collect a Confederate force; and, when the boats were within three miles of Jacksonboro', they were turned back and pursued by sections of flying artillery from Parker's (Marion), from Walter's (Washington), and from Shulz's (Chesnut) batteries. The result was, that one of the smaller boats was crippled, set on fire, and abandoned, the others escaping to Beaufort. From the wreck two valuable field-pieces were saved and taken into the Confederate service.

While these operations were in progress, General Beauregard had received reinforcements. He therefore held a consultation with his generals as to the feasibility of expelling the invaders from Morris Island. But the conclusion reached was, that "means of transportation were so limited as to render it impossible to

<sup>1</sup> "General Gillmore afterward remarked to General Terry that the night of our withdrawal from James Island was to him the most anxious one in his military experience." (*W. W. H. Davis.*)



throw sufficient reinforcements on the island in one night, and in time to allow the advance of our troops to the south end before daylight." (*Military Operations*, vol. ii. pp. 115, 116.)

The descent on Morris Island was thus a successfully accomplished fact. The Union troops were occupying nearly three miles of the southern part, leaving the Confederates to hold one mile of the northern part, with two strong fortifications, but with their communications with the city seriously threatened and impaired.

The defense on the 10th of July was not so vigorous as it might have been, even allowing for the heavy odds against the Confederates. The fire of their eleven pieces, mostly of large calibre, did little or no execution. Some of the guns could not be depressed to bear on the landings. It would have been better had the gunners not wearied themselves out fighting the Folly Island batteries for two hours, but had reserved their fire to be concentrated on the boats as they advanced to land the troops. General Gillmore remarks in his report that a few well-placed field-guns would have done better.

Nor was any stubborn resistance made from the rifle-pits by the small support of infantry, so overwhelmed was it by the batteries, the flanking fire from the monitors, and the charge of four times its own number from the landing. The shattered and exhausted companies reached Fort Wagner in a very disorganized condition, which lasted late into the night. And if an assault had been made that evening the whole island might have fallen. The Union army certainly lost a great opportunity.

About midnight fresh troops were brought from Charleston, particularly the Georgians, and a more determined spirit prevailed at once. The repulse inflicted on the enemy the next morning served to encourage the defenders of Morris Island and to confirm the purpose of the commanding general to hold it as long as possible.

## CHAPTER V.

### THE SECOND ASSAULT OF BATTERY WAGNER.—FORT SUMTER THREATENED.

July 12-August 12, 1863.

SIEGE-BATTERIES CONSTRUCTED ON FIRST PARALLEL AGAINST WAGNER—BRIGADIER-GENERAL TALIAFERRO COMMANDS THE CONFEDERATES ON MORRIS ISLAND—MAJOR RION'S SORTIE ON THE NIGHT OF JULY 14TH—GREAT LAND AND NAVAL BOMBARDMENT OF WAGNER, JULY 18TH—FIRE CEASES AT DARK AND GARRISON CALLED OUT—THREE BRIGADES OF UNION TROOPS PREPARE FOR ASSAULT UNDER BRIGADIER-GENERAL SEYMOUR—STRONG'S BRIGADE, LED BY SHAW'S COLORED REGIMENT, GAINS THE PARAPET, BUT IS BEATEN BACK IN GREAT DISORDER—PUTNAM'S BRIGADE, DELAYED TOO LONG, GAINS AND HOLDS A SALIENT OF THE WORK, BUT IS FORCED TO RETREAT AFTER HEAVY LOSSES AND CAPTURE OF PRISONERS—THE UNION TROOPS FINALLY REPULSED AFTER A STRUGGLE OF NEARLY THREE HOURS—CONFEDERATE LOSSES—CONSTRUCTION OF BREACHING-BATTERIES AGAINST FORT SUMTER BEGUN JULY 23D AT UNPRECEDENTED RANGE OF 4200 YARDS—EXCHANGE OF PRISONERS AUGUST 3D—ARMAMENT OF FORT SUMTER REDUCED, BY REMOVAL OF TWENTY GUNS, TO A TOTAL OF THIRTY-EIGHT GUNS AND TWO MORTARS—FILLING OF GORGE-ROOMS WITH WET COTTON-BALES AND SAND—SALLY-PORT CUT THROUGH WESTERN WALL AND WHARF CONSTRUCTED—MERLONS AND TRAVERSIS CONSTRUCTED ON RAMPARTS—EXTERIOR OF GORGE PROTECTED WITH SANDBAGS BROUGHT FROM THE CITY—MAGAZINES MADE SAFE—TWO CAPTURES BY THE HARBOR FLOTILLA.

IMMEDIATELY after the failure in front of Battery Wagner steps were taken by the Union commander, Brigadier-General Q. A. Gillmore, to construct batteries against it, so as to shake it violently before another assault. These works, four in number, mounting twenty-seven rifle guns, 10-, 20-, and 30-pounders, and fourteen mortars, were begun on the night of July 12th by Major T. B. Brooks, A. D. C. and assistant engineer. They

were located on what he termed the first parallel,<sup>1</sup> and they varied in distance from 1330 to 1920 yards.

But it does not appear that any thought of the necessity of besieging Wagner by regular approaches entered the mind of the Union commander at this early date. These forty-one or two guns and mortars, supported by the heavy flanking fire of the armored vessels, were relied on to demoralize the garrison and ensure an easy capture of the fort. So respectable, if not formidable, had this seaside resort of the Confederates become that henceforward it was to occupy a very conspicuous place in the military operations before Charleston.<sup>2</sup> Yet the sequel proved that Fort Sumter could have been demolished and the city annoyed by long-range rifle-guns without the digging of a single trench or the firing of a single gun against Wagner, or perhaps the sacrifice of a single life before its impregnable ramparts. (See "Strategic Value of Morris Island," Appendix E.)

Colonel R. T. Graham, who had commanded the Confederate troops on the island during the engagements of the 10th and 11th, was relieved on the morning of July 14th by Brigadier-General William B. Taliaferro. This officer, a native of Virginia, having served with "Stonewall" Jackson in some of his most active and brilliant campaigns, reported for duty in the department, and was assigned first to the District of Georgia, March 6, 1863. Some time after May he appears to have been transferred, at his own request, to the First Military District of South Carolina, and continued in its organization to render most valuable service for nearly two years.

In order to inspirit the garrison and feel the enemy, who occupied rifle-pits about three-fourths of a mile from Wagner, the order was issued by General Taliaferro on the night of his arrival to organize a sortie, and the command of it was given to Major James H. Rion, Seventh battalion South Carolina.<sup>3</sup>

<sup>1</sup> But it was not so called by General Gillmore until after July 18th.

<sup>2</sup> "This was one of the strongest earthworks ever built, and gave evidence of the highest order of engineering ability." (Brigadier-General W. W. H. Davis, U. S. Vols., "Annals of the War," *Philadelphia Times*, 1879.)

<sup>3</sup> No mention of this bold sortie appears in the "Confederate Defense of Morris Island," *Charleston Year-Book*, 1884. Major Rion served the State with distinction in war and in peace. He died in 1886.

With detachments from the Fifty-first North Carolina and Twentieth South Carolina regiments, also from the Twelfth and Eighteenth Georgia battalions and his own command, in all one hundred and fifty men, Major Rion pushed forward about midnight, and encountered first the pickets, then a heavy fire from the troops in the entrenched line, which seemed to be destructive to some of their own men in the act of retreating. Prisoners taken gave information of the new works in progress, and, the object being attained, Major Rion withdrew, having lost 11 wounded (1 mortally) and 3 missing. He estimated the Union loss at upward of 40. The Confederate rifle-pits on "the ridge" two hundred yards in advance of Wagner were then reoccupied.

While the batteries for the new attack were under construction the monitors and gunboats of the fleet furnished a daily supply of about three hundred shot and shell to the Confederates on Morris Island. But the casualties were very few, and the injuries to the works no greater than could be easily repaired by the working-parties every night.

At length came the 18th day of July, made memorable by a land and naval bombardment of uncommon severity, lasting eleven hours, and followed by the second assault of Wagner. This was bravely made, but stubbornly resisted, and it ended in a bloody and disastrous repulse of the Union forces.

General Taliaferro had under his command at this time on the northern end of Morris Island about thirteen hundred men. The garrison of Wagner consisted of the following infantry: the Charleston battalion, Lieutenant-Colonel P. C. Gaillard, assigned to the right; the Fifty-first North Carolina, Colonel H. McKethan, posted at the centre; the Thirty-first North Carolina, Lieutenant-Colonel Charles W. Knight, assigned to the defense of the left of the work. The artillery companies of Captains W. T. Tatom and Warren Adams, First South Carolina Infantry, of Captains J. T. Buckner and W. J. Dixon of the Sixty-third Georgia (heavy artillery), and of Captain William L. De Pass (light battery), were all under command of Lieutenant-Colonel J. C. Simkins, chief of artillery. Two field-howitzers on the extreme left were in charge of

Lieutenant T. D. Waties of the First South Carolina Artillery (regulars).

In the forenoon, while the Union batteries were making ready after the delay caused by a drenching rain the night before, there was preliminary practice with the mortars, getting the range of Battery Wagner. From 9 A. M. five gunboats shelled the fort, but by noon the entire fleet of armored vessels and wooden gunboats began to move up and take position for their day's work. Soon after midday all the land and naval guns opened together, maintaining a fire of the utmost violence for eight hours upon the little fort. Rear-Admiral Dahlgren, having his flag on the monitor *Montauk*, was accompanied by the *New Ironsides* and four monitors, besides the gunboats on the station, five in number. These latter used their pivot rifle-guns with good effect at long range. The Union fire, land and naval combined, must have been from sixty-four guns and mortars actually engaged. These were opposed by the Confederate guns from Wagner, Gregg, Sumter, Moultrie, and the works on James Island, some thirty odd, making on both sides a total of about one hundred guns of the heaviest calibre, firing almost incessantly for eight hours. A dense cloud of smoke hung over the fort, the batteries, and the ships of war, while the deafening roar of heavy ordnance seemed to be unbroken through all the lengthened time. The tide serving about 4 P. M., the iron-clad squadron closed in with the redoubtable little work "to about three hundred yards, which silenced it so that, for this day, not a shot was fired afterward at the vessels nor was a man to be seen about it." Its two guns on the sea-face were dismounted by the heavy fire after some reply.

The troops of the garrison were carefully disposed by the commanding general, so as to suffer no more than twenty-eight casualties during the day. The detachments of artillery occupied the several gun-pits or places, deriving some shelter from the traverses, parapets, and merlons around them.

"The infantry, except the Charleston battalion, and the artillery, except the gun detachments, were placed shortly after the shelling

commenced under cover of the bombproofs. The first-named battalion, with a heroic intrepidity never surpassed, animated by the splendid example of their field-officers, Lieutenant-Colonel P. C. Gaillard and Major David Ramsay, had no protection except such as the parapet afforded them, yet maintained their position without flinching during the entire day. . . . As night approached the increased severity of the bombardment plainly indicated that an assault would be made, and orders were issued to the command to prepare to man the ramparts." (Report of Brigadier-General Taliaferro.)<sup>1</sup>

A little after sunset the thunder of the bombardment ceased, and when the lull came with the departing day everything was made ready for the approaching struggle. Then appeared the wisdom of many of the defensive precautions taken by both the artillerists and the engineers of the post. The chief engineer of the department, Lieutenant-Colonel D. B. Harris, had come down from the city in a small boat to Cumming's Point, and made his way under the perilous fire to the little fort at the very height of the bombardment. His cool demeanor, earnest spirit, and sagacious judgment impressed and encouraged all who came into his company, and contributed greatly to the final result, which he remained to see. Not only had the massive earthwork proved the thoroughness of its plan and construction by its wonderful endurance, but the batteries had been so well protected on all the faces of the work as to admit of their being put in immediate condition and readiness for action. This was due to some thoughtful and energetic measures adopted during the day, such as stopping the embrasures with sandbags, and even covering up many of the lighter guns on the land side with the same, so as to preserve them from injury until they should be wanted. Most of all, the care taken to preserve the magazine from danger was now about to be proved and rewarded. All the troops, with the exception of

<sup>1</sup> The rear-admiral received a signal from General Gillmore in the afternoon informing him that the assault would be made at twilight. This signal was read by the Confederates and communicated to General Beauregard, but whether it was communicated to General Taliaferro or not is uncertain, as he testifies to having no recollection of having received it. It was hardly necessary to be more assured of the coming event than he had already been by the warning fire he had received.

the command, took their places at the guns and along the parapet and awaited the signal of battle.

So far from finding the garrison unprepared for assault, General Gillmore reports that as the head of his column left the line of his batteries the guns in Wagner, Gregg, and Sumter, and also those on James and Sullivan's Islands, opened upon it rapidly and simultaneously. This was at 7.45 P. M., when the advancing Federals were first seen from Wagner.

The brigade of G. C. Strong, headed by the Fifty-fourth Massachusetts (colored) regiment, under Colonel Robert C. Shaw, led the assault. Another "made-up" brigade, under Colonel H. S. Putnam, followed in supporting distance, and Stevenson's brigade was held in reserve; the whole force, about 6000 strong, being commanded by Brigadier-General Truman Seymour.<sup>1</sup>

Shaw's colored regiment of six hundred men came forward on the "double quick," but, breaking at the ditch of Wagner under the withering fire, and leaving some brave comrades with their dashing colonel dead on the parapet, it rushed like a crowd of maniacs back to the rear. The other troops of Strong's brigade, caught in the narrow part of the island by these desperate fugitives, were thrown into great disorder. The Ninth Maine and the Seventy-sixth Pennsylvania regiments were affected by the panic, and soon General Strong found that he had only the Sixth Connecticut and the Forty-eighth New York regiments left to do any fighting for him. Fragments of these

<sup>1</sup> "The division was accordingly formed on the beach and moved to the front. It consisted of three fine brigades. The first, under Brigadier-General Strong, was composed of the Forty-eighth New York (Colonel W. B. Barton), Seventy-sixth Pennsylvania (Captain J. S. Littell), Third New Hampshire (Colonel J. H. Jackson), Sixth Connecticut (Colonel Chatfield), Ninth Maine (Colonel S. Emery), and, temporarily, the Fifty-fourth Massachusetts (Colonel Shaw). The second brigade, under Colonel H. S. Putnam, Seventh New Hampshire, consisted of the Seventh New Hampshire (Lieutenant-Colonel J. C. Abbott), One Hundredth New York (Colonel G. B. Dandy), Sixty-second Ohio (Colonel F. B. Pond), and Sixty-seventh Ohio (Colonel Alvin C. Voris). The third brigade was commanded by Brigadier-General T. G. Stevenson, and consisted of four excellent regiments." (Report of Brigadier-General Seymour.) These troops were from the Tenth and Thirteenth army corps.







Colonel D. E. HARRIS,  
Chief Engineer Department of S. C., Georgia and Florida, 1862-64.  
Brigadier-General October, 1864.  
From a Photograph.

commands bravely struggled on the slope and parapet of the fort, vainly striving to get within, but the brigade was broken, while General Seymour was pressing Colonel Putnam to move up to the support with his command. The latter contended that he had been ordered directly from the commanding general to remain where he was, but after some embarrassing delay he did advance.

By this time General Strong and Colonel Chatfield of the Sixth Connecticut had fallen mortally wounded, battling with their brave men close up to the enemy. Putnam's brigade charged gallantly, and some of his men, about one hundred, with himself for their leader, took possession of the south-eastern salient of the fort, a bastion-like shelter. (Brigadier-General Seymour's report, agreeing with *Personne* in the *Charleston Courier*.) Here should have been the Thirty-first North Carolina from the beginning of the attack; but instead of being manned by the troops assigned for its defense, the place was left unprotected, all efforts to get the men out of the bomb-proof having proved unavailing.<sup>1</sup> Heavily traversed on three sides, this salient afforded secure lodgment for a time. General Seymour reports: "Strong efforts were made by the enemy to drive our brave fellows out, but unsuccessfully, and rebel officers and men were captured and sent to the rear."<sup>2</sup> For more than an hour this position was maintained by Colonel Putnam, assisted by Colonel Dandy, One Hundredth New York, Major L. Butler, Sixty-seventh Ohio, W. B. Coon, Forty-eighth New York, Captain D. Klein, Sixth Connecticut, and a number of other very brave and devoted officers." Here Colonel Putnam was shot dead on the parapet. Before this, while the Second brigade was moving up to the assault, Brigadier-General Seymour was severely wounded by a grape-shot, and was obliged to leave the field. He had already sent orders for Stevenson's brigade to advance to the support of Putnam, and he repeated the order before he was borne to the rear. But Stevenson never moved:

<sup>1</sup> This regiment distinguished itself the next year in Virginia by gallant conduct on the field of battle.

<sup>2</sup> Only Lieutenant James Campbell of the Charleston battalion and a few privates.

Putnam's brigade, like Strong's, was broken ; and the commanding general soon after gave up the struggle, without apparently making any use of the Third brigade.

The Federals in the salient were now cut off from all support, but they defended themselves well against terrible odds. In one of the unsuccessful attacks made on them Captain W. H. Ryan of the Charleston battalion was killed. But finally they yielded to a sharp fire maintained by the Fifty-first North Carolina, and particularly to a flanking attack by a portion of the Thirty-second Georgia, which under Brigadier-General J. Hagood had arrived during the action and been "sent along the parapet to the left and on the top of the magazine to approach their rear." (For Brigadier-General Taliaferro's report, see Appendix.)<sup>1</sup>

The fight lasted with varying and declining violence for nearly three hours. The Union loss was very severe, and it is difficult to arrive at an exact statement of it. General Gillmore does not give it in his report of operations, but on the authority of Rear-Admiral Dahlgren (*Memoirs*, page 419) he spoke of it as having been not less than 1500. The loss in Colonel Shaw's regiment was officially reported to have been 262 out of 624 ; that of the Seventh New Hampshire to have been 218. From a comparison of all accounts, it seems fair to estimate the total loss at nearly 2000 killed, wounded, and captured. Among the killed were Colonels R. G. Shaw and H. S. Putnam, with Lieutenant-Colonel Green ; Brigadier-General G. C. Strong and Colonel J. L. Chatfield were mortally wounded ; and Brigadier-General T. Seymour, Colonels W. B. Barton, A. C. Voris, J. H. Jackson, and S. Emery were among the wounded. Lieutenant-Colonel Bedell, Third New Hampshire, and Major Filler, Fifty-fifth Pennsylvania, were among the prisoners.

<sup>1</sup>Among the incidents of the day, "the commanding general himself was buried knee-deep in sand" (by the explosion of a shell) "and dug out with spades." About 10 A. M., when the garrison flag had been carried away by a shot, it was gallantly replaced by Major David Ramsay, Sergeant William Shelton, and Private John Flynn of the Charleston battalion ; again, by Captain Robert Barnwell of the Engineers, and Lieutenant W. E. Reddick, Sixty-third Georgia. Later, it was replaced by Private A. Gilliland of the Charleston battalion.

The Confederate loss amounted to 174 killed and wounded. Among the former were Lieutenant-Colonel J. C. Simkins and Captain W. T. Tatom, First South Carolina Infantry; also Captain W. H. Ryan of the Charleston battalion and Lieutenant G. W. Thompson of the Fifty-first North Carolina. Major David Ramsay, Charleston battalion, was mortally wounded.<sup>1</sup>

Twice foiled in his attempts to get possession of Battery Wagner, the Union commander changed his plans in two leading particulars. Battery Wagner was now to be besieged by regular approaches, and Fort Sumter was to be demolished from ground already in his possession. The heavy Parrott rifles, 100,- 200,- and 300-pounders, which had been brought to Morris Island for this purpose, might, in fact, have been put in position a fortnight earlier than they were, and both of those disastrous assaults on Wagner avoided. The range

<sup>1</sup> The present writer claims to have sought accuracy, but for both accuracy and fullness of particulars he must refer the reader to a contribution in the Philadelphia *Weekly Times*, April 18, 1885. The author, Major-General Sam. Jones, once in command of the Department of South Carolina, Georgia, and Florida, has taken the greatest pains to give all the particulars, and his history of operations before Charleston, related in this and other issues of the same journal, is of permanent value to the whole country.

Lieutenant-Colonel John C. Simkins, a native of Edgefield county, South Carolina, while quite a youth, enlisted for the Mexican War as private in the Palmetto regiment. Obtaining soon after a commission as first lieutenant in the newly-raised regiments of regulars, U. S. army, he was twice wounded and then made captain by brevet. Leaving the service after the war, he returned to farming in Edgefield. On the outbreak of the Confederate War he was commissioned captain in the First regiment of infantry (regulars) of South Carolina. In this command he served mostly on Sullivan's Island, being promoted to the rank of lieutenant-colonel of his regiment.

Captain William H. Ryan, a native of Charleston, held the rank of first lieutenant in the Irish Volunteers before his company was united with the Charleston battalion.

Captain William T. Tatom, a native of Abbeville county, South Carolina, received a military education in Georgia.

Major David Ramsay of Charleston died of his wound August 4th. A graduate of the Charleston College, he completed his studies with a course of two years in Germany, and, returning to his native city, entered upon the practice of law. He was not quite thirty-three years of age at the time of his death, being a grandson of Dr. Ramsay, the historian of South Carolina, and on his mother's side a great-grandson of the eminent patriot and statesman, Henry Laurens.

of those large Parrott rifles was something unprecedented in warfare, being from 4000 to 8000 yards, and that secured the demolition of Sumter without any respect to Wagner.

It has been already told how Fort Sumter rendered valuable assistance to its gallant outposts on Morris Island. Scarcely had the advance of the assaulting column been descried on the opening of the 18th, when the barbette battery of Fort Sumter, with two mortars firing from the parade, opened effectively on the approaches to Wagner, and in particular on the ground where the reserves were stationed. Through the deepening shadows of the twilight the garrison watched the onset, the struggle, the final repulse. The rattle of musketry and the dull reports of the siege-howitzers could be plainly heard; so also, at times, even the cheering of the foemen, while the constant sparkling and flashing of the small-arms looked like an electric chain or a pyrotechnic display. The news of the repulse was received at the fort before midnight.

In a few days after the fight the glasses of the officers could make out, from the ramparts of Fort Sumter, the new works pressed rapidly to completion by the Federals for the mounting of their breaching artillery specially intended for its reduction. These works seemed far in advance of Wagner. In fact, the first work, begun July 23d, next to the marsh and to the rear of the first parallel, was at a distance of 4200 yards from Sumter. Others quickly followed, and the fresh sand in yellow heaps would tell what preparations were making for renewed attack.

One of the most important changes going on at the fort at this time was in its armament. From the date of the enemy's descent on Morris Island it had been steadily reduced, the guns being sent to new works on James Island and the inner harbor. In this way the barbette guns of the western or left flank of the fort,<sup>1</sup> together with those of the casemates generally, were disposed of. More than twenty guns and mortars were withdrawn. The armament, thus reduced, remained up to the opening of the first bombardment as follows:

*Left flank barbette (western)*—Two IX-inch Dahlgrens.

<sup>1</sup> Some "quakers" were put in their place.

*Left face barbette (north-western)*—Two 10-inch columbiads, two 8-inch columbiads, four 42-pounders.

*Right face barbette (north-eastern)*—Two 10-inch columbiads, five rifled and banded 42s.

*Right flank barbette (eastern)*—One XI-inch Dahlgren, four 10-inch columbiads, one 8-inch columbiad, one rifled 42-pounder, one 7-inch Brooke rifle.

*Gorge barbette*—Five rifled and banded 32s and one 24-pounder.

*Parade*—Two 10-inch mortars.

*Salient second tier casemates*—Three rifled and banded 42s.

*Lower tier casemates, on right and left faces*—Two navy VIII-inch and two 32s.

Making the total armament of Fort Sumter at this date, the end of July and on to August 17th, to have been thirty-eight guns and two mortars.

The working force under the engineer in charge, Lieutenant John Johnson, had been greatly increased, varying from three hundred to four hundred and fifty blacks, coming and going in reliefs night and day. It has been already mentioned that sand from the parade of the fort had been used to fill up the casemates, upper and lower, of the sea-front or right flank. It now became necessary to consider the protection of the gorge against the land-batteries, a matter of paramount importance. The gorge, although closed, was not as massively built as the other parts of the fort, and unless strengthened the breaching of it would uncover the whole interior of the work. But sand from the parade, which had been freely used to fill the casemates of the sea-front, was becoming scarce; the transportation of it from the city was very limited; so, to economize material and make bulk out of something else, bales of steam-compressed cotton, well soaked in salt water, were supplied to the engineer, with orders that they should be laid in sand as bricks in mortar.<sup>1</sup>

<sup>1</sup> HEAD-QUARTERS DEPT. SOUTH CAROLINA, GEORGIA, AND FLORIDA. )  
CHARLESTON, S. C., July 15, 1863. )

LIEUTENANT-COLONEL D. B. HARRIS,

Chief Engineer Dept. South Carolina, Georgia, and Florida—

COLONEL: In addition to the works ordered in my communication of yesterday's date, the commanding general further directs that the gorge-wall of

The doing of this work involved more labor than any other single part of the defense. Seventeen rooms used for officers' quarters, eight lower and nine upper rooms, all eighteen feet six inches square, the former having a height of eleven feet, the latter a height of fourteen feet, had to be filled without a moment's loss of time. There would have been eighteen rooms, but the space of the sally-port was reserved for future use, and an exterior protection was provided for it. Begun on the 20th of July, this work required the labor of one hundred and fifty men, working by day, and the same number, a fresh gang, by night, for three weeks, being completed just in time for service.

The filling of two rooms simultaneously was conducted on the following plan: A bed of sand two feet thick was first laid on the flooring; upon this six bales of wet cotton were laid with intervals of two feet between them in every direction; then sand, moistened and well rammed, filled the spaces; another layer of cotton-bales, separated from the first by two feet of sand, and so on until the room was filled. In this way twelve bales were required for each lower and eighteen for each upper room. The flooring gave way, as expected, but only so far as the filling of the lower rooms permitted, and that was trifling. Except a slight odor of burnt cotton on the first day of the bombardment, which may have proceeded from a loose sample, no sign of combustion was ever observed, and the plan, thoroughly tested, was proved to be highly efficient. One great advantage it possessed over an ordinary filling with sand was in retaining almost a perpendicular condition after the brick wall had been knocked away from it; and all fear of its taking fire was removed when it was discovered, after some openings had been made, that the wet cotton had become rotted or soured and refused to burn; this it continued to do even when incendiary shells were fired

Fort Sumter be strengthened by means of wet cotton-bales, filled in between with wet sand and kept moist by means of tubes or hose from the upper *terreplein*.

Respectfully, your obedient servant,

THOMAS JORDAN,  
*Chief of Staff.*

for days together into the gorge. No measures were taken to keep the filling moist, as this was unnecessary.

It had been apparent for some time that a new wharf and sally-port would have to be constructed, the stone quay on the gorge, with its adjacent sally-port, being entirely exposed to the enemy. Accordingly, one of the lower casemates on the western or city front, near to the north-western angle of the fort, was devoted to the purpose; the tedious work of enlarging the embrasure to the dimensions of a gateway was begun, and steps were taken to build a timber wharf projecting about fifty yards from the exterior of the fort into deep water. This double work, begun July 16th, was completed in nine days.

As soon as the heavy labor of these undertakings had been performed for the security of the gorge and the transportation, the working force was put to protecting the fine barbette battery of the right flank by suitable merlons and traverses. This battery was nearly enfiladed by some of the new positions selected by Brigadier-General Gillmore on the inner or marsh line of Morris Island. The material, sand revetted with bags, it was necessary to elevate in large quantities to the levels of the *terreplein* and parapet—viz. to a height of thirty-four and forty-eight feet above the parade. The traverses, four in number, were massive, being thirteen feet high above the *terreplein*, and with a top thickness each of fifteen feet, the bases in the usual proportion.

Lastly, as the enemy's preparations advanced toward completion, a measure of defense which had at first been suggested, but then postponed on account of difficulties, or rather scarcity of transportation, was again agitated, and at length ordered by the commanding general.<sup>1</sup> This was the building up from the

<sup>1</sup> It was mainly due to the earnest soliciting and devoted personal services of the late Mr. Williams Middleton that this additional protection was given to the exterior of the gorge, strengthening it to the last moment of time allowed for work. He superintended the filling of the bags and the loading of the boats.

The following paragraph from the *Charleston Mercury*, August 4, 1863, will furnish a good idea of the determination in the city: "We would again earnestly call the attention of all our citizens, not in the ranks, to the important movement now afloat to furnish sandbags for the protection of our harbor



stone quay of the gorge, where a base of twenty-four feet was afforded, of a continuous counterfort of sandbag work, designed to add something to the masonry counterforts and to the already well-packed officers' quarters of that locality, but chiefly designed to reach and protect with added thickness the parapet itself. But the work was too great for even the energy which the crisis lent to all engaged. Every bag of sand used had to be brought from the city by night and put in place before morning. A record kept shows that the work, begun on the night of the 4th of August, was pressed nightly until the 17th—that is to say, for two weeks—but the supply of material was not abundant enough for the working force, nor the time sufficient for any approach to completion. The total number of bags of sand brought to the fort for the purpose was twenty thousand, about one-third of the whole number required for this object. With these the old sally-port was first protected, it being now used for a bombproof shelter, and the western half of the gorge-scarp was covered up to the height of about twenty-five feet, with a top thickness of only six feet and a bottom width of from fifteen to twenty feet.

Thus, from the 10th day of July, when the descent on Morris Island was made by the Union troops, to the middle of August, a large force had been kept working day and night at the task of strengthening the fort to meet its first bombardment. As many as four hundred and sixty hands were employed during the last week of preparation. The sequel proved that unless this preparation had been made in time the fort could not have been held. The five weeks were faithfully employed by all: the engineer department had used all diligence, from the chief to the humblest laborer; the quartermasters had done their best with inadequate transportation; the garrison of the fort had been worked hard, until officers and men alike required a resting-spell to prepare them for the impending struggle.

During this period there occurred two exploits by the naval

defenses. Messrs. Williams Middleton and T. Jefferson Bennett have taken charge of the matter on South Commercial Wharf, at the desire of the military authorities. Boats and carts are employed in conveying sand and the bags when filled. Bags are wanted."

officers in the harbor which served to prove that they could well assume the offensive when an opportunity offered itself.

The former, known as an "Affair of Pickets at Vincent's Creek, August 4, 1863," is described below in one of General Ripley's reports, the date being given by him, in mistake, as August 5th. There had been an effort made by the Confederate engineers to establish a battery on a little rise or shell-beach in the marsh near the southern outlet of Vincent's Creek, or Schooner Creek, soon after the first assault on Battery Wagner. The site was only about 1400 yards west of Wagner, and most favorably situated for a flanking fire directly in its front. But the communications were hazardous and exposed to the enemy's small boats coming from the rear of the island. A small steam-transport, the *Manigault*, grounded here during the construction of the battery, and, being discovered the next morning by the enemy, she was soon set on fire by their shells and burned to the water's edge. Her hull remained to add an obstacle to the further construction of the work, and it was from that time abandoned. But the Union boat-pickets at once established themselves there as a base from which to annoy the communications between the city and Cumming's Point of Morris Island. It became known as "Payne's Dock," so called after Captain L. S. Payne, of the One Hundredth New York regiment, distinguished as a daring scout.

"The enemy, having established an annoying picket-guard at an unfinished battery at the mouth of Vincent's Creek, he was attacked at about nine o'clock P. M. (August 4th) by a party from the navy and from the Twenty-fifth South Carolina volunteers, under Lieutenant commanding A. F. Warley of the Confederate States steamer *Chicora*, Captain M. H. Sellers commanding the land force. The party proceeded in four boats, guided by Mr. J. Fraser Mathewes, to the northern entrance of Lighthouse Creek, where Captain Sellers landed and proceeded against the enemy's picket. Lieutenant Warley (and Lieutenant John Payne), with two boats, went round to the mouth of Vincent's Creek to cut off the enemy's barges. A brisk skirmish ensued, which resulted in the capture of one boat, with one captain (Lewis S. Payne) and ten non-commissioned officers and privates of the enemy, of which the captain and four non-commissioned officers and privates were wounded, one mortally. The remainder of the enemy's party were driven off in another boat under a heavy fire, which undoubtedly caused them some damage. On our side one private of the Twenty-fifth South

Carolina volunteers was killed." (Brigadier-General Ripley's report of operations.)

The latter of the two affairs was the capture of a valuable launch and part of her crew by the small armed steamer *Juno*, a blockade-runner put in command of Lieutenant Philip Porcher of the Confederate Navy. The annexed account is copied from the *History of the Confederate States Navy*, J. Thomas Scharf, New York, 1887 :

"On the following night (August 5th-6th) Commodore Tucker went on board the *Juno* and ordered Lieutenant Porcher to set out on a reconnoitring-tour of the harbor. Porcher had ten of his crew armed with rifles, and their instructions were to fire upon any of the Federal picket-boats that might be encountered. Steaming cautiously along below Morris Island, the *Juno* came upon and took by surprise the first launch of the frigate *Wabash*, which had on board a crew of twenty-three men and a 12-pounder howitzer, while the steamer was unarmed save for her riflemen, her two guns having been removed when she was put in trim for a blockade-runner. Porcher did not hesitate for that reason, but ran down the launch; and his onslaught was so swift and sudden that the crew attempted no defense. A dozen threw themselves into the sea, five were drowned, and seven swam to other picket-boats, by which they were rescued. The remainder surrendered, and Porcher took possession of the launch and brought eleven prisoners to Charleston. He was highly complimented by Flag-Officer Tucker, and the fine launch and her gun came into good use against their former owners."

Shortly after this exploit the valuable life of this officer was lost by the foundering of the *Juno* on a blockade-running trip to Nassau, N. P.

## CHAPTER VI.

### FIRST GREAT BOMBARDMENT OF FORT SUMTER—FIRST PERIOD.

**August 17-23, 1863.**

EXPERIMENTAL PRACTICE WITH LIGHT AND THEN WITH HEAVY GUNS—RECORD OF DAMAGES—FORCE AND ARMAMENT OF BREACHING-BATTERIES ON MORRIS ISLAND—THEY OPEN HEAVY FIRE ON SUMTER, AUGUST 17TH—FIRE SLACKENED AT NIGHT, TO BE RESUMED NEXT MORNING AND CONTINUED FOR A WEEK—OPERATIONS IN THE FLEET AND ON MORRIS ISLAND—FIRING, DAMAGES, AND CASUALTIES IN FORT SUMTER—THE FORT SUFFERS A SERIOUS NAVAL ATTACK FOR TWO HOURS AND A HALF BY MONITORS ON THE NIGHT OF AUGUST 22D-23D—NARROW ESCAPE OF THE MAGAZINE—ORDNANCE STORES REMOVED AT GREAT RISK—THE FORT CANNONADED AGAIN BY THE BREACHING-BATTERIES, AND TECHNICALLY DEMOLISHED BY THE END OF THE SEVENTH DAY, AUGUST 23, 1863—THE MARSH BATTERY OPENS FIRE ON THE CITY OF CHARLESTON.

BEFORE the breaching-batteries erected by General Gillmore against Fort Sumter began their destructive work the fort was made the target for a little playful practice on the 20th day of July. Some of the 30-pounder Parrott rifles, mounted on the first parallel to operate on Wagner, were turned on Sumter, and eight shots were fired to get the range. This light artillery was only intended to interrupt the communications from the city with the fort and with Cumming's Point; it had no battering power. But being the first firing on the fort by land-guns since Major Anderson's time, April, 1861, and a drummer-boy named John C. E. Graham, while standing in the sally-port, having been seriously wounded by one of the shells, it is here recorded. Again on the 25th the same guns fired six shots at the fort, the distance being 4300 yards.

The first fire of heavy guns mounted for battering purposes

was on the 12th of August. But this was only preliminary, for as the works begun on the night of the 23d of July were successively completed their guns would be tried by a few discharges until they were all made ready. So it happened that between the dates of August 12th and 17th, when the bombardment fairly began, there was experimental practice with the great guns almost daily, morning and evening, though with but one or two at a time. The chief importance of this preliminary fire to the fort and its garrison was that the effects of single shots could be better observed and estimated at this period than later, when the firing was more rapid and the damage from single shots was less distinguishable from the general ruin.

To give the best idea of the powers of the new battering engines upon the best brick masonry at ranges varying from 3400 to 4200 yards, it will be necessary to quote a few passages from the engineer's journal.

Among the eighteen shots striking the fort on the 12th of August, one is recorded as passing over the gorge-wall and parade, descending into the casemates of the second tier on the left face (north-western front), near the spiral staircase, and doing the following damage: "The projectile, a percussion shell from an 8-inch Parrott rifle, commonly called a 150- or 200-pounder, exploded, destroying the baking-ovens of the fort and causing a half bushel of bricks to fall from the under side of the arch below upon the gun mounted in the casemate beneath. This effect was not due to penetration, but to the shock of the explosion on the floor above. These lower casemate arches have only twelve inches thickness of brickwork at the crown and about twenty inches at the haunches. It was at the crown that the injury was received. The upper casemates are covered by arches twenty inches thick throughout." No casualty attended this shell.

But another, "passing over the western angle of the gorge and descending on the outside, struck the little steamboat Hibben, then unloading at the new wharf. It penetrated the boiler, the steam scalding severely nine negro laborers, some of them fatally. Curiously enough, the shell (8-inch rifle) was

found apparently unexploded in the after hold of the boat, but without any charge or fuze-plug in it."

A bolt from the same gun "struck the outside of the gorge-wall at the level of the *terreplein*, or rather of the arch sustaining it. The crater opened in this old masonry was but three feet in diameter and one and a half feet deep, but beyond the crater the projectile had penetrated three feet four inches, thus making the total penetration on the slant line of fire, nearly  $40^\circ$ , equal to four feet ten inches. The measuring-rod was stopped by the base of the shot itself, imbedded in and nearly quite through the wall, which is here five feet thick. As this was the first shot illustrating the effective breaching power of the guns, the sketch here shown has been added to give an idea of the crater and penetration of the bolt." The sandbag work on the exterior of the gorge-wall at this place had been extended no higher than the floor of the upper room, filled with sand and cotton-bales.

The destructive effect of three shells entering the gorge-scarp at the parapet and near together was very marked. The first almost penetrated the parapet, two feet and a half below the superior slope, "humping or bowing it upward twenty inches and for twelve feet of its length, shattering the wall to the inside, and throwing brick and fragments of shell upon the *terreplein*.

The gorge-scarp is generally five feet thick, but that portion of it constituting the lower half of the parapet is only four feet three inches thick, being weaker than any of the other parapets, which all maintain the full five feet thickness of the scarp. The second, occurring the next day, carried away three feet of the

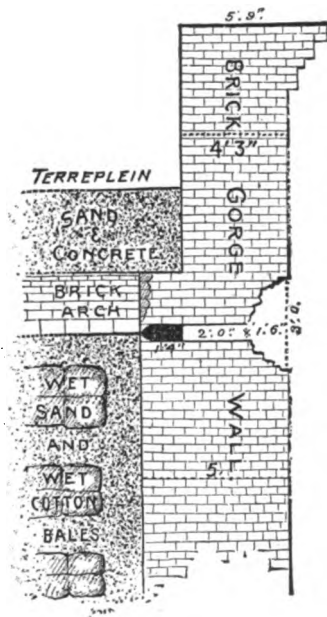

EFFECT OF AN 8-INCH SHELL ON GORGE-WALL.

parapet from the exterior crest inwardly, and smashed the inner part through to the interior slope for a length of twelve feet. The third continued the destruction, and rendered the parapet unserviceable for thirty feet of its length, while for twelve feet it was entirely demolished.

These particulars of damage done by connected or separate shots will aid the mind in appreciating the combined firing about to be endured by the devoted fort. Further, it will be necessary to record the following details concerning the breaching-batteries, as given by Brigadier-General J. W. Turner, chief of staff and of artillery, in the appendix of Major-General Gillmore's report of operations :

"The batteries, commencing on the right, ran around to the left as follows:

"*Battery Brown*.—On right of second parallel, near the beach. Distance from Fort Sumter, 3516 yards. *Armament*.—Two 8-inch Parrott rifles (150- or 200-pounders). *Garrison*.—Company I, Third Rhode Island Heavy Artillery, commanded by Captain Charles G. Strahan.

"*Battery Rosecrans*.—Near left of second parallel. Distance from Fort Sumter, 3447 yards. *Armament*.—Three 100-pounder Parrott rifles. *Garrison*.—Company M, Third Rhode Island Heavy Artillery, and a detachment of the One-Hundred-and-Seventy-eighth New York volunteer infantry, commanded by Captain J. J. Comstock, Jr., Third Rhode Island Heavy Artillery.

"*Battery Meade*.—Near left of second parallel, in front of Battery Rosecrans. Distance from Fort Sumter, 3428 yards. *Armament*.—Two 100-pounder Parrott rifles. *Garrison*.—Detachments from Third Rhode Island Heavy Artillery, the One-Hundredth New York volunteers and One-Hundred-and-Seventy-eighth New York volunteer infantry, commanded by First Lieutenant Henry Holbrook, Third Rhode Island Heavy Artillery, and after his death by First Lieutenant A. E. Green, Third Rhode Island Heavy Artillery.

"*Naval Battery*.—Centre of first parallel, 200 yards north of Beacon House. Distance from Fort Sumter, 3980 yards. *Armament*.—Two 8-inch Parrott rifles and two 80-pounder Whitworths. *Garrison*.—Detachments of sailors from the United States frigate Wabash, under Commander Foxhall A. Parker, United States Navy.

"*Battery Hays*.—On creek, 312 yards west of Beacon House. Distance from Fort Sumter, 4172 yards. *Armament*.—One 8-inch Parrott rifle. *Garrison*.—Detachments of Company D, Third Rhode Island Heavy Artillery, under command of Captain R. G. Shaw.

"*Battery Reno*.—On creek, 135 yards west of Battery Hays in sand-

ridge. Distance from Fort Sumter, 4272 yards. *Armament*.—One 8-inch Parrott rifle, two 100-pounder Parrott rifles. *Garrison*.—Company H, Third Rhode Island Heavy Artillery and a detachment of the One-Hundred-and-Seventy-eighth New York volunteer infantry, commanded by Captain A. W. Colwell, Third Rhode Island Heavy Artillery.

“*Battery Stevens*.—Immediately to the left of Battery Reno. Distance from Fort Sumter, 4278 yards. *Armament*.—Two 100-pounder Parrott rifles. *Garrison*.—Detachments of Company C, First United States Artillery, and Seventh Connecticut volunteer infantry, commanded by First Lieutenant James E. Wilson, Fifth United States Artillery.

“*Battery Strong*.—Immediately to the left of Battery Stevens. Distance from Fort Sumter, 4290 yards. *Armament*.—One 10-inch Parrott rifle. *Garrison*.—Detachment of Seventh Connecticut volunteer infantry, under Captain S. H. Gray.”

Summed up, the guns were—two 80-pounder Whitworths, nine 100-pounder Parrotts, six 200-pounder Parrotts, and one 300-pounder Parrott; in all, eighteen rifle-guns in eight batteries, throwing a ton of metal in the aggregate at each discharge.

**FIRST DAY.**—At five o'clock on the morning of the 17th of August, 1863, began the first heavy bombardment of Fort Sumter by the Union forces on Morris Island. According to Major-General Gillmore, it terminated, after seven days' firing, in the demolition of the fort. But the fort was not silenced until the night of the 1st of September, or it may be said until the end of the sixteenth day. At the close of the seventh day the fort could fire from its barbette battery of the right flank two 10-inch columbiads and one XI-inch Dahlgren gun.

On the first day eleven rifles only were employed against the fort—viz. two 80-pounders, five 100-pounders, and four 200-pounders—some throwing shell (with percussion fuzes), others throwing shot.<sup>1</sup> The fire was almost entirely directed upon the left flank and face, taking the latter in reverse. By 9 A. M. upward of two hundred shots had been fired, the practice being astonishingly accurate and the effects severe. One shell, explod-

<sup>1</sup> Brigadier-General Turner reports to Major-General Gillmore that Battery Kirby threw shells from two 10-inch sea-coast mortars. But this must have been at Wagner, not at Sumter, which was much too distant. No mortar-firing on Sumter is chronicled by the Confederates until after the Union forces had gained possession of the northern end of Morris Island, September 7, 1863.



ing in the third story of the eastern barracks, wounded six men ; in the parade and elsewhere two others were soon after wounded and one was killed. The last was struck, while standing close under the cover of the gorge in the south-eastern angle of the parade, by the flying back of the base of a Parrott shell which exploded diagonally across the parade, a hundred yards or more distant. The singular precision with which this large mass flew backward on its line of fire, and the fact that, later in this bombardment, another man lost a leg in the same spot and from the same cause, may have been due to the pattern of the shell, which is very light near the base and heavy at the point or apex of the cone.

The fleet of iron-clads and gunboats had engaged the works on Morris Island from an early hour. At 10.45 A. M. one monitor and four gunboats opened on Fort Sumter very ineffectively at long range. By 11 A. M. the total firing from land and sea amounted to about five hundred shots. The shock of the 200-pounder Parrott bolts striking the scarp of the gorge could be plainly felt by any one standing or sitting in the upper casemates of the right face ; that is, entirely across the parade. At 11.10 A. M. the fort opened with the XI-inch (Keokuk) gun, and the entire barbette battery of the right flank upon the iron-clads at long range, and continued firing until they withdrew at 12.30 P. M. Sixty-four rounds were expended with no observable result.

The fire of the land-guns slackened between 1 and 2 P. M. Brigadier-General R. S. Ripley, commanding First Military District of South Carolina, visited the fort and inspected damages. The vigor of the bombardment was soon resumed, and maintained until darkness set in. Then it slackened again to about one shot in fifteen minutes from 30- and 100-pounder rifles, and so continued all night.

The parapet of the gorge was for more than half its length demolished ; the second and third stories of the western barracks, except a portion under cover of the gorge, were in ruins. Seven guns in barbette on the gorge, the left flank, and left face of the fort had been disabled. Some of the upper casemates of the left face had been damaged. During the day the garrison

not on duty, as well as the working force of blacks, had found safe shelter under cover of the gorge or within the splinter-proof blindage at its base. The casualties were surprisingly few, and generally not serious, being nineteen in all—one enlisted man killed, two seriously and thirteen others slightly wounded. The following officers were also slightly wounded: Lieutenants John Middleton and Julius M. Rhett, First South Carolina Artillery, and Lieutenant John Johnson, engineer in charge. The garrison at night lowered two 42-pounders from the ramparts into the parade for shipment. The working force was engaged all night discharging and building upon the exterior of the gorge fifteen hundred bags of sand, also in completing sand-filling over the magazines within, and in protecting with sandbags two lower casemates of the western front, so as to make them safe for a hospital.

Colonel D. B. Harris, chief engineer of the department, visited the fort at 9 P. M., and was accompanied through his inspection by Colonel Alfred Rhett, commanding, and by the engineer in charge.

The total firing between 5 A. M. of the 17th and 5 A. M. of the 18th of August was 948 shots, of which 445 struck inside, 233 struck outside, and 270 passed over the fort.

After this first day's battering fire from those eleven rifled guns it became a settled conclusion that the ruin of the brick Fort Sumter was an assured thing, a matter of time alone. Henceforth it became the duty of the defense to delay the demolition as long as possible, and to save all material of war that could be spared. That night a large quantity of ammunition and stores was removed from the fort to Sullivan's Island.<sup>1</sup>

<sup>1</sup> The operations of this day (17th) included a heavy cannonade of Batteries Wagner and Gregg by the entire naval forces of the enemy, even the gunboats taking part at long range. The fire of Wagner upon the breaching-batteries of the second parallel engaged upon Fort Sumter was effective and galling. Not even the mortars and lighter rifles of the land-batteries, aided by the fleet, could entirely subdue the pugnacious little fort, doing good service for Sumter. It was not until some of the heavy battering-guns, mounted for the exclusive benefit of the latter, had been turned on Wagner that the annoyance ceased. (Gillmore.)

So likewise on the sea-face Wagner's two 10-inch columbiads and one rifled

SECOND DAY.—On the morning of the 18th the fire was resumed heavily with three more guns, making for the second day a total of fourteen. The gorge directly and the left face in reverse received most of the battering. It was found that the counterforts of stone masonry erected on the exterior of the gorge a year before for the protection of the lower magazines were unhurt. Brick masonry, used to continue them up to the level of the upper magazines and not two months old, was badly damaged. But then these upper magazines had been already abandoned, and there was nothing to be feared from them. The western half of the gorge, partly protected with sandbag work, showed little damage except on the level of the parapet. This was more or less demolished, and at the angle of the fort nearest Morris Island a large crater, opened by the day's battering just below the crest, revealed the purpose of the enemy to undermine and topple over the heavy traverse of sandbags which had just been raised at that important point.

An evidence of the immense power of the Union artillery, and of the combined effect of those heavy shocks already described as being felt from one end of the fort to the other, was given in the discovery of a remarkable crack in the main wall of the fort, from the parapet continuously and perpendicularly down to the berme or rocky base at the water's edge. The crack was visible for its whole length, forty feet, being one-quarter of an inch open at the parapet, diminishing to one-sixteenth of an inch at the base. It was not quite so plain on the inside of the wall. As it was found on the scarp of the western or city front, in no connection whatever with the marks of firing, but near the angle made by that front with the gorge, it may be accounted for by supposing that the vibrations of the gorge-scarp under its

and banded 32-pounder fought the fleet. (For effect upon *New Ironsides*, see Appendix B.) Soon after the monitor *Catskill* engaged the work a 10-inch shot from *Wagner*, striking the top of the pilot-house, shattered the inner plating and caused the instant death of Commander George W. Rodgers and Acting Assistant Paymaster J. G. Woodbury, together with the wounding of two others. Battery Gregg made good practice on the monitors, striking the *Passaic* (flag) with repeated shots. Battery *Wagner* was but little damaged, but sustained a serious loss in the death of Captain J. M. Wampler of the Engineers. (See Colonel Keitt's full report in Appendix.)

heavy blows would be arrested by the inertia of the adjacent untouched scarp-wall on the left, and that just there, at the fulcrum of leverage, the fracture would occur. In support of this it may be added that the masonry of the scarp-wall throughout the fort was nowhere tied or bonded into the masonry of the piers and arches of the casemates, but was merely in contact, and the more liable on this account to show the effect of the vibrations.

Inside the fort the work of destruction was becoming more apparent. The western barracks were ruined, the casemates of the left face, both upper and lower, were considerably damaged and weakened by the heavy fire in reverse, which was cutting away the piers, and had already brought down one of the upper arches, in its fall breaking the level of the terreplein and uncovering the inside face of the scarp-wall. The spiral staircase in this vicinity was nearly destroyed. More guns were disabled, including two valuable 10-inch columbiads in open air on the right face, taken in reverse. The garrison flag, twice cut away, was gallantly replaced by Private John Drury, Company B, assisted by Sergeant Schaffer. The casualties were slight, three men having been wounded.

The working force was put on immediately after dark, and, as there was no firing on the fort during this night, its labor was uninterrupted.

During this, the second day of the cannonade, 876 shots were fired, 452 striking outside, 244 inside, and the remainder passing over the fort.<sup>1</sup>

**THIRD DAY.**—As early as the light permitted on the morning of the third day the batteries opened with the addition of

<sup>1</sup> This day (18th) the trenches of the Federal approach were flooded with water from the spring-tide, driven by a gale from the north-east. The *New Ironsides*, with two monitors and some gunboats, again cannonaded the batteries of Morris Island; the *New Ironsides* alone threw 805 shells on this and the previous day into Wagner. It appears from despatches that Major-General Gillmore looked for a sortie in force from Wagner early this morning to raise the siege and stop the firing on Sumter; but it has been already recorded in a previous chapter that such a step was considered impracticable on account of limited transportation.

one more gun, making fifteen. Before noon a shot passed entirely through the gorge, finding an opening between the under side of a rampart arch and the sand and cotton filling of one of the upper rooms. The mass had begun to settle a little, and the shot, plunging through, dropped in the parade of the fort. On subsequent inspection, at 12 M., the scarp of the gorge appeared to have been breached by several shots striking about the same place, under the crown of the arch; but this was the only missile that passed through the gorge that day, or indeed during the whole of this first bombardment. As a rule, the scarp of the gorge was thoroughly sustained by the backing of the filled-in rooms, formerly the officers' quarters, assisted by the accumulation of débris falling on the outside from the parapet above and caught in places by the unfinished sandbag work and stone counterforts of the exterior.

The firing in reverse received by the northern casemates was very destructive. Four upper and three lower embrasures had been more or less shattered. In the afternoon a 42-pounder gun was seen to fall, with its carriage, chassis, and circle all together, from the terreplein into the ruins beneath; the sustaining piers of its arch had been finally shot away.

Brigadier-General Ripley visited the fort at 5 P. M., and soon after the iron-clad squadron moved up as if to attack or reconnoitre; the vessels, however, lay at long range and did not open fire. Fort Sumter took four shots at them with the Keokuk's gun, and they withdrew, magnanimously declining to reply, but shelling Morris Island as they went.

The fire on the fort slackened as usual at dark, but at long intervals was kept up all night. The repairing of damages, and chiefly the securing of two lower casemates for hospital purposes on the city front, occupied the working force. Mr. T. A. Evans reported for duty, relieving Messrs. E. J. White and W. E. Mikell, assistant engineers.

The total firing on the third day and night reached 780 shots, of which 408 struck outside, 241 inside, and 131 passed over. The casualties were limited to one killed and four wounded.<sup>1</sup>

<sup>1</sup> The approaches of the Federals on Morris Island this day (19th) were kept up, but, being checked by the sharpshooters and artillery, the progress

FOURTH DAY.—Three new guns, one of them a 10-inch Parrott rifle, known as a 300-pounder, were added to the battering engines on the next day, being the fourth of the bombardment. There were, in all, eighteen rifles, 100-, 200-, and 300-pounders, firing from the now completed breaching-batteries upon Fort Sumter. The direction of the firing had been mainly upon the centre and left of the fort ; it began this day to incline more to the right, threatening the few remaining serviceable guns of the right face and flank.

On the eastern half of the gorge four upper rooms had been partially uncovered by the falling away of the scarp-wall, but the wet sand and cotton-bales resisted firmly at that level, while the débris, accumulating and reaching a height of fifteen feet, effectually strengthened the remaining work for at least two-thirds of its height. The western half of the gorge was all the more favorably circumstanced, having, besides the débris, its unfinished sandbag work of from ten to fifteen feet thickness. *So that the prolonged stability of the gorge as an effectual cover to the southern half of the parade could now be counted upon. For the same reason the safety of the lower magazines, the only magazines then used, could be reasonably expected.* These were most satisfactory conclusions, and did much to encourage the defense of the post. On the other hand, this very protection to the gorge furnished in places from this day forward a practicable slope from the water's edge for an assault by small boats.

A very singular incident occurred in the course of this day's cannonade. The circumstances were as follows : It was reported that a shell had penetrated the gorge and passed through the old sally-port into the parade. This was incredible, knowing that the sally-port had been closed and protected on the exterior with sandbag work twenty feet in thickness. On examination, the report was proved to be untrue, but a strange thing had hap-

pened. From one point in particular, about two hundred and forty yards in front of Wagner—the "ridge," as it was called—there was an effective fire of small-arms maintained on the trenches. The flanking fire from the Confederate batteries, multiplying on the shore of James Island, though at long range, was now beginning to be felt by the Federals, and required more caution on their part. The New Ironsides alone engaged Wagner during the day.

pened. A rifle shell with percussion fuze had struck the gorge-wall six feet above its base, to the right or east of the heavy sandbag work and in an angle of the *caponnière*, but its slant direction of fire, nearly  $45^\circ$ , had turned it toward the open archway of the sally-port and away from the wet cotton-packed room that would otherwise have stopped it. Still, it had not penetrated through to the interior; only the fuze-plug had done so, making its own narrow track, and leaving the shell buried in the wall some twelve inches behind it. The fuze-plug had passed into the open space and was picked up in the parade. The accompanying sketch will illustrate this curious occurrence. It was a

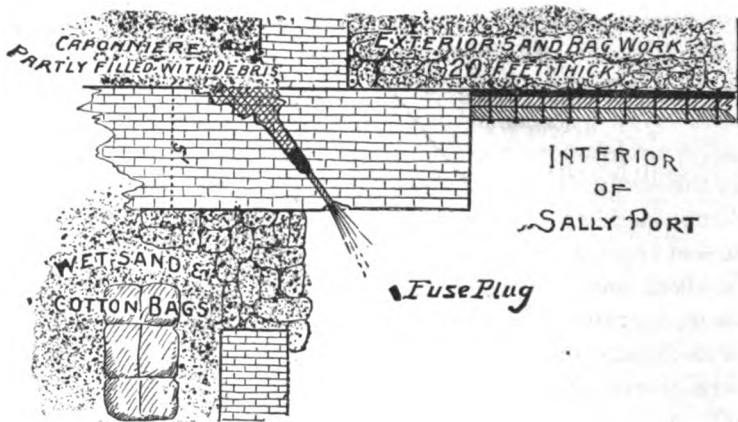

PLAN SHOWING THE PENETRATION OF A SHELL AND FUZE-PLUG.

chance shot, causing no casualty; and as the *débris* on the outside soon piled up so as to protect the wall almost as effectually as the sandbag work, no other shot ever again penetrated in the same locality.

The firing in reverse on the interior of the left face had at length opened a clear breach of eight feet horizontal by ten feet vertical in the wall of the upper casemates. This first wide gap of ruin was a sad sight to those who remembered the old fort in its glory. Other breaches in the same region were progressing, but this was the first and the largest; it corresponded with the locality of greatest damage in the crest of the gorge, and served to mark the central line or focus of fire as the fort

was presented to the batteries. (It is shown on the interior view at page 166.)

The working force was busily engaged all night, increasing the sandbag protection on the exterior of the western magazine and securing the hospital casemates in the same vicinity. There was no firing on the fort during the night. The garrison was employed in removing and shipping twenty-five thousand pounds of powder and other ammunition.

The total firing of the fourth day was 879 shots, of which 408 struck outside, 241 inside, and 131 passed over the fort. There were three slight casualties.<sup>1</sup>

**FIFTH DAY.**—With the regularity of clockwork the cannonade of the fifth day opened as usual, but with the direction of fire changed to the eastern half of the fort. The hours of daylight, from 5 A. M. to 7 P. M., were fourteen, and these, with a slight slackening at the dinner-hour, were continuously occupied in the service of the breaching-batteries. It is described by the Union authorities as having been very arduous: even passing to and from the batteries added to the fatigue; the camp on the southern end of Morris Island was nearly a mile to the rear of them, the intervening ground being within range of the Confederate flanking-batteries on James Island. The tour of duty for a relief with the breaching-batteries was four hours on and eight off; each gun had three reliefs of cannoners, with two or three others for magazine service. Heavy labor incurred in handling the weighty projectiles for the service of the pieces was specially provided for by fatigue-parties regularly detailed for the work. Brigadier-General Turner, chief of artillery, reports to Major-General Gillmore: "The precision of fire of the Parrott rifles was remarkable, probably excelling any artillery ever before brought on the field in siege operations." And in this testimony all the Confederate authorities fully concur.

<sup>1</sup> The Ironsides, with four gunboats, continued to shell the garrisons of the advanced works on Morris Island all this day (20th of August.) Three Confederate batteries on James Island, Simkins, Cheves, and Haskell, now flanked with annoying fire the Federal approaches on Morris Island, although mounting only smoothbore guns and distant from three to four thousand yards.



The fire on this fifth day, as has been said, was plainly directed upon the right face (in reverse) and in enfilade of the right or eastern flank of the fort. The guns in open air on this flank had been heavily traversed and further protected with merlons, but the enemy's artillery was too strong for them. One 10-inch and one 8-inch columbiad on the flank, and one 10-inch columbiad with two banded and rifled 42s on the adjoining face, were soon disabled. The eastern scarp began to show some damage from even the slant fire it was now receiving, large craters having been opened under each of the heavy traverses, and the parapet having been demolished at the south-eastern angle. The stone counterfort of the magazine at this angle was unhurt, being protected with débris.

At noon, Colonel A. Rhett, commanding, with Major O. Blanding, Captain F. H. Harleston, and Lieutenant J. Johnson, engineer in charge, held a conference on the subject of defense. About sunset General Beauregard, accompanied by Colonel J. Gilmer and Lieutenant-Colonel Harris of the corps of Engineers, visited and inspected the fort. Brigadier-General Ripley and staff came for the same purpose at 10 P. M.

The working force having begun to show signs of great fatigue, consequent upon the difficulty of sleeping in the daytime during the noise of the bombardment, requisition was made for a fresh relief of labor. More powder, nine thousand seven hundred pounds, was shipped at night.

The firing of the day, there being none at night, amounted to 943 shots, of which 430 struck outside, 320 inside, and 193 passed over the fort. The casualties were two men severely and four slightly wounded.<sup>1</sup>

<sup>1</sup> About 11 A. M. this day (21st of August) a demand from Brigadier-General Gillmore on General Beauregard for "the immediate evacuation of Morris Island and Fort Sumter" was delivered near Fort Wagner. No answer having been received within the time stipulated, four hours, the Federal commander ordered fire to be opened on the city of Charleston about two o'clock in the morning, when shells from the Marsh Battery were thrown among the sleeping inhabitants without any practical warning having been given them. It appears that some accident and misunderstanding were at the bottom of this; for, through difficulties of transportation, through the absence of

SIXTH DAY.—Soon after the fire opened this morning the fine 7-inch Brooke rifle at the south-eastern angle was disabled, and later a 10-inch columbiad and a rifled and banded 42-pounder shared the same fate. There were thus left only four guns in serviceable condition at this juncture. At quarter-past 12 the principal flagstaff in the salient, which had been repeatedly splintered, fell crashing into the parade, and the colors were henceforth flown from the crest of the gorge. At 5 P. M., in consequence of a communication by the French consul with the fleet, the fire slackened and ceased. It had amounted to 604 shots, of which 203 struck outside, 216 inside, and 185 passed over the fort. There were no casualties.

During the night repairs were made on the merlons and traverses of the eastern or right flank, which had been greatly injured by the day's firing. But the work was interrupted, first by a necessary transfer and relief of hands, and last by an attack of the iron-clad squadron. One hundred and twelve fresh hands were received, two hundred and sixteen were sent off, and the force remaining numbered two hundred and twenty.

At 3 A. M. five monitors—the Weehawken (flag), Montauk, Nahant, Patapsco, and Passaic—anchored about 800 yards (Dahlgren) from the fort and opened fire. The early morning was foggy, and this, with the darkness, gave the vessels great advantage—one, in fact, that it is strange they did not oftener take. The first shell, passing over the eastern wall, struck and

General Beauregard from the city, and through the omission of Brigadier-General Gillmore's signature from the demand, much time was lost, and the opportunity of warning the citizens before retiring to rest was not given. The demand was returned for signature, and then formally refused by the commander. The Federal commander afterward extended the time, giving two days' notice, and suspending the bombardment of the city until the night of the 23d of August.

The New Ironsides, with one monitor and two gunboats, engaged Wagner, the land-batteries joining in toward evening. An attack of infantry made upon the "ridge" at dusk was repulsed, the Confederates being reinforced promptly by Brigadier-General Hagood, commanding at Wagner. Among the casualties of the day at the post was the death of Captain Robert Pringle, of Lucas's battalion of artillery, a meritorious young officer from the city of Charleston.

mortally wounded a sentinel on the top of the western wall. His piercing screams were remarkable, and must have been heard by the enemy. As heard by those in the fort, the sound they made, breaking upon the stillness of the night, was longer to be remembered than the loud artillery. About fifty shot and shell, one-third missing the mark, were discharged at the fort. Three shells were thrown with accuracy into the immediate neighborhood of the western magazine, giving cause for alarm, but doing no injury; one sent bricks and dust down the ventilator from a height of thirty feet; and another, exploding in the upper casemates, threw a fragment into the ordnance store-room, where three hundred loaded shells were kept ready for service: this room was adjoining the magazine. The commanding officer, Colonel Rhett, instantly ordered a detail of one hundred men to roll down into the water these dangerous explosives, and it was done under the superintendence of Lieutenants Iredell Jones and William H. Grimball. The monitors drew upon themselves the fire of Sumter, Gregg, Moultrie, Bee, and Beauregard. Sumter fired only six shots from two guns, the Keokuk's XI-inch Dahlgren and a 10-inch columbiad: they were all that were left in a serviceable condition, and they were *the last fired in action from the crumbling walls of the fort*. The vessels could not be seen at all from Sullivan's Island until after four o'clock, when it grew lighter, and then the first reply came from Fort Moultrie. Indistinctly seen as the monitors were, they were repeatedly hit by the guns on Sullivan's Island (Dahlgren). About 5.30 A. M. they withdrew from action.

Together with the night-firing, that of the day (August 22d) amounted to 654 shots, of which 220 struck outside, 230 inside, and the remainder passed over the fort. The casualties were—one mortally and four slightly wounded.<sup>1</sup>

SEVENTH DAY.—The land-batteries opened on the fort, as

<sup>1</sup> The services of the New Ironsides and two monitors were found necessary this day (22d of August) to subdue the fire of Wagner upon the approaching sap and the most advanced breaching-battery. The navy purposed attacking Sumter before daylight, but failed to do so, coming in the next morning, as above.

usual, just after daylight, and continued firing upon the right face and flank. At 2 P. M. a shell, descending on the northern end of the eastern barracks, passed through the roof, and, breaking the brick-arched floor of the third story, threw down into the room below large masses of brick and mortar upon some officers at table eating dinner. Colonel A. Rhett escaped with a cut from his dinner-knife broken in his hand; Captain D. G. Fleming was unhurt; Adjutant S. C. Boylston was painfully, Lieutenant E. S. Fickling, and Lieutenant C. A. Scanlan, ordnance officer, were slightly wounded; an orderly entering the room was also hurt.

The firing ceased at 6.30 P. M. The eastern wall was very much injured, and in places deeply penetrated. Its parapet was badly shattered, owing somewhat to the fire of the monitors the night before; the service of the only two remaining 10-inch guns was rendered difficult, and the XI-inch Dahlgren alone continued in good condition.<sup>1</sup>

Work was begun at once on the interior (or parade) exposure of the western magazine, to protect it from such another fire in reverse as it had received from the monitors, and might receive again before another morning dawned. This was felt to be a critical place and a critical time. Lieutenant-Colonel Harris, chief engineer, visited the fort after midnight, and was accompanied by the engineer in charge in an inspection of damages.

The flagstaff, planted at this date on the crest of the gorge, had been twice shot away from that point, and had been previously deprived of its colors seven times. The garrison found hard work ready for it in the shipment from the fort of more powder and ordnance stores. The casualties of the day and night were two severely and four slightly wounded; the total number of shots fired was 633, of which 282 struck outside, 210 inside, and

<sup>1</sup> Simultaneously with the firing on Sumter this day (23d) there was some heavy shelling of Wagner by both the land and naval guns, the little fort managing to get in not a few damaging shots upon the head of the sap, and also upon the New Ironsides, her chief tormentor. A fine launch, cut away by a shot from the latter, drifted ashore and was captured. Lieutenant-Colonel P. C. Gaillard, commanding the Charleston battalion, lost his left hand at Wagner this day.

the remainder missed the fort. Fort Sumter was practically demolished, though not yet silenced.

NOTE.—On the night of the 21st–22d of August the 8-inch rifle opened on the city from the Marsh Battery, range 7900 yards.

“Colonel E. W. Serrell, the constructor, says that the distinctive features of the Marsh Battery as a work of engineering were ‘that the gun-platform was placed upon a gun-deck resting upon vertical sheet piling, outside and around which there was a grillage of logs. If the gun and the other weights upon the gun-deck were heavy enough to tend to sink in the mud, the weight upon the grillage, in the form of sand in bags, which formed the parapet and epaulement of the battery, by being increased counterpoised the gun-deck. It was simply a force meeting another force of a like amount in an opposite direction.’ The English journal, *Engineering*, in its review of the operations of the Federal and Confederate armies, at the close of the war, speaks of the construction of this battery as one of the most important engineering works done by either army. It was a successful piece of difficult engineering, and a practical method of inflicting damage on a city nearly five miles distant, regardless of its army, its cannon, and its great fortifications, which were within close sight and easy range.” (*Battles and Leaders*, Century Company.)

The “Swamp Angel,” so called by the Union soldiers, was purchased, with a number of other condemned cannon, at the close of the war by the late Charles Carr, founder, of Trenton, N. J. It lay at his foundry several years, and, being loth to melt such an historical relic, he united with a number of public-spirited citizens and took means for the preservation of the piece. A pedestal nearly twenty feet high was erected at the junction of Clinton and Perry streets, just beyond the Normal School buildings, and the cannon was hoisted to its position on the summit. Six lamps are placed beside it and a drinking-fountain is beneath. The following is an exact copy of the inscription cut in the brownstone. As will be observed, it is guiltless of a single punctuation-mark :

“*The Swamp Angel.*”—The first gun an 8 inch Parrott rifle or 200 pounder fired from the Marsh Battery on Morris Island South Carolina at the city of Charleston 7000 yards weight of gun 16500 pounds and of projectile 150 pounds charge of powder 16 pounds greatest elevation used 35° bombardment opened August 21 1863 burst 36th round.” (*Philadelphia Times.*)

## CHAPTER VII.

### THE FIRST GREAT BOMBARDMENT—SECOND PERIOD.

August 24th-September 2d.

DESCRIPTION OF CANNONADE—GREAT LOSS OF MATERIAL BY THE FORT—SUPPLIED ONLY BY SAND AND OTHER MATERIAL BROUGHT NIGHTLY FROM THE CITY—FAILURE OF THE UNION COMMANDERS TO INVEST MORRIS ISLAND—THE SECOND PERIOD MARKED BY A DECLINE IN FIRE—PARTICULAR DAMAGE DONE BY THE 300-POUNDER PARROTT RIFLE—NOTES OF INTEREST CONCERNING THE GUN—COUNCIL OF DEFENSE HELD AT THE FORT, AUGUST 24TH, BY THE CHIEF ENGINEERS AND OTHER OFFICERS—GENERAL BEAUREGARD DETERMINES TO DEFEND THE FORT TO THE LAST EXTREMITY—CHANGES IN THE GARRISON—INFANTRY TROOPS SENT DOWN TO ASSIST THE ARTILLERISTS—THE WORK OF SAVING DISMOUNTED GUNS FROM THE RUINS BEGUN BY ASSISTANT ENGINEER J. FRASER MATHEWES—THE STEAMER SUMTER, TRANSPORTING CONFEDERATE TROOPS ON THE HARBOR, SUNK BY THE GUNS OF FORT MOULTRIE—SEVERE NIGHT-ATTACK BY THE IRON-CLAD SQUADRON, INCLUDING THE NEW IRONSIDES—THIS ATTACK, OF FIVE HOURS' DURATION, MORE SERIOUS THAN THAT OF APRIL 7TH—FORT SUMTER AT LENGTH SILENCED—THE MAGAZINE ESCAPES FROM THREE WELL-AIMED SHELLS—THE SQUADRON'S FIRE RETURNED WITH EFFECT FROM SULLIVAN'S ISLAND—THE FORT LEFT WITH FEW PLACES OF SAFETY, AND OPEN TO ASSAULT ON THE GORGE, BUT WITH MASSIVE BARRIERS OF EARTHWORK NEXT TO THE ENEMY—AFTER SIXTEEN DAYS' BOMBARDMENT FORT SUMTER LOSES ALL OFFENSIVE CHARACTER FOR SIX WEEKS.

WHAT may be called the first period of the first bombardment of Fort Sumter closed with the operations of the 23d of August. For seven days the breaching-batteries of General Gillmore were served vigorously against the fort. Their ponderous missiles, thrown with great precision of aim and with a range beyond all precedent, had wellnigh done their work of destroying the strong artillery post. An observer from its

battered walls could watch the shot and shell rising from little clouds of white smoke far away among the low hills of Morris Island. Sometimes, two or three in sight at once, they would come rushing on their way, and as they neared the fort would be heard hissing and tearing through the air straight to their mark—at one moment, to bury themselves far within the solid masonry; at another, to crush the mass to fragments, sending up clouds of dust or scattering the *débris* to the winds and waves.<sup>1</sup> So charged with gases did the ruined heaps become that one could see the smoke escaping slowly from the crevices of the mass, as from the crater of a volcano, long after the force of the shell had been expended; and the peculiar odor of the percussion-powder used for the fuze-plug of the shell so pervaded everything that the air in the fort seemed to be entirely composed of it. One singular circumstance attending this heavy firing of the first bombardment was that, owing to the great distance of some of the guns, the report of the gun firing a shell would be almost merged into the sound of the bursting of the shell itself at the fort.

The decisive marking of this first period was made by General Gillmore's despatch to Washington on the 24th, reporting "the practical demolition of Fort Sumter as the result of our seven days' bombardment of that work." In correspondence with Admiral Dahlgren, General Gillmore expresses at this time his confidence that "the offensive power of Sumter was entirely destroyed from to-day's (August 23d) firing;" and he further advocates the immediate investment of Morris Island by closing communication at night with a complete cordon of army and navy picket-boats around Cumming's Point. The admiral, it appears, had agreed with the general as to the practicability of the above

<sup>1</sup> This wasting of material was enormous: it was so much lost from the defensive power of the fort, and nothing but *new* material brought for repairs could replace it. It has been a popular but a serious mistake to represent that the protection of Fort Sumter was mainly due to the *débris* accumulating from its own demolition and protecting the garrison by its fortuitous piling up of rubbish. The *débris* alone could never have sufficed for the defense of the fort, however skilfully disposed. An expression commonly used has been that "the more the fort was battered, the stronger it became." Nothing could be farther from the truth, except with the understanding that new material was constantly required and supplied.

plan ; and it could have been rendered still more formidable by the application of the calcium light, which the general had been perfecting, so as to illuminate the approach to the island from Fort Sumter and the city. Yet, with all the advantages of this perfectly practicable scheme, it appears never to have been attempted. Indeed, the co-operation of the navy and army in thus investing the island could just as well have been secured for the plan at a much earlier date, and the Confederate troops on the island have been starved into terms and captured.<sup>1</sup>

Day after day, for upward of five weeks, the communications of Morris Island had been completely commanded by the Union batteries, and when night set in the supply and relief of Morris Island by the Confederates had to be made under great risks and difficulties. It only needed a combined dash of the enemy's barges from within and from the outside to have entirely interrupted the communication. It would have been a fight with small-arms at night on the water, in which the batteries could not have taken part for fear of injuring friend as well as foe ; and the issue could not have been doubtful.<sup>2</sup>

The second period of the first bombardment of Fort Sumter dates from the morning of the 24th of August. As a period it was marked by a great decline in the firing of the breaching-batteries. During six days, from the 24th to the 29th inclusive, the fort received a constantly lessening fire ; then, on the morning of the 30th, a heavy cannonade began again, declining on the 31st of August, but resumed with full vigor on the 1st of September ; and at length, with the naval attack on the fort on the night of 1st and 2d of September, the first bombardment in both periods came to its end. It will be necessary now to particularize.

During these nine days of the second period the demolition of the fort was greatly increased by the firing of the 300-pounder

<sup>1</sup> Gillmore, *Operations*, 137.

<sup>2</sup> An attempt of this kind on the night of August 24th, or what is called "the first assault on Gregg," is described with full particulars by the writer of a paper on the "Confederate Defense of Morris Island." (See *Charleston Year-Book*, 1884.) But after diligent search for other authorities I have been unable to find any mention whatever, by either side, of such an occurrence.—  
J. J.



Parrott rifle. In one day it threw fifteen thousand pounds' weight of metal.<sup>1</sup> It was directed against the exterior of the right flank and the interior of the right face of the work. One shot, striking in reverse the upper tier of casemates, cracked a massive pier entirely through and partially destroyed it. The thickness on the line of fire was seven feet; squarely across, five feet. The pier, one-half brick with a filling of concrete, had been built twelve years. Another evidence of this rapid power of destruction occurred later, on the 30th of August, when after eight hours' battering in the same vicinity it destroyed one entire casemate arch, bringing down the *terreplein* with gun, carriage, etc. These arches, built of best gray brick laid in cement, were twenty-two inches thick, while on the line of axis they were twenty-one feet long.

The same work of destruction required three or four days the week before on the part of the 100- and 200-pounder rifles. Still more, on the 1st of September the effect of its fire was to culminate in the fall, at the same instant, of four upper casemates, with *terreplein*, platforms, and guns. The following notes relative to this powerful rifle will be found interesting in this place:

"The 10-inch required a little greater elevation, to attain the same range, than the 8-inch, but was more accurate. It was mounted on an iron carriage with a centre-pintle chassis, and worked with great ease. Steps were cut in the parapet upon which Nos. 1 and 2 mounted to load: the projectiles were carried on hand-barrows. Unfortunately, it was disabled soon after opening fire by a premature explosion of a shell near its muzzle, which blew off about eighteen inches of its length. It was repaired, etc. . . . The gun was fired three hundred and seventy times after this, without any appreciable difference in the range or accuracy being noticed. Subsequently, it was completely disabled by continued premature explosions of shells near the muzzle." (Gillmore, Appendix.)<sup>2</sup>

It was on the 24th of August, at the close of the day, that

<sup>1</sup> W. W. H. Davis.

<sup>2</sup> "The 300-pounder gave great trouble before it was got into position. • It was transported more than a mile from the dock through deep sands and across semi-marsh overflowed by the tide. It broke down three sling-carts. It was about a week on the way, and in the daytime it was covered with brush and weeds to conceal it from the enemy." (General Davis, *Philadelphia Times*, "Annals of the War.")

Colonel J. F. Gilmer,<sup>1</sup> chief engineer of bureau, and Lieutenant-Colonel D. B. Harris, chief engineer of department, reached the fort, under orders from General Beauregard, to convene a council of defense with officers of the post. Accordingly, Colonel Rhett, Major Blanding, and Captain Harleston of the garrison, with Lieutenant Johnson, engineer in charge, met the senior engineers in conference. The minutes of the conference have been preserved in full by General Beauregard,<sup>2</sup> and may be read also in the Appendix of this chapter.

The chief engineers, on returning to the city, reported to the general commanding that they had visited the fort, "made a careful examination of its condition, and held a consultation with a portion of its officers." So far from thinking it advisable to abandon the fort, they thought it should be held to the last extremity. "How long it may hold out," they say, "is now only a matter of conjecture, but there are many elements of defense within the fort in its present shattered condition which if properly used may enable a resolute garrison to hold

<sup>1</sup> HEAD-QUARTERS DEPT. OF SOUTH CAROLINA, GEORGIA, AND FLORIDA, }  
 (CHARLESTON, S. C., August 31, 1863. }

(*General Orders No. 95.*)

Major-General J. F. Gilmer, P. A. C. S., having reported for duty in connection with the defense of Charleston, is announced to the forces as *second in command* to the commanding general. He will be obeyed and respected accordingly.

By command of General Beauregard.

(Signed)

THOMAS JORDAN,

*Chief of Staff.*

Official: CLIFTON H. SMITH,

*A. A. General.*

September 2d.

This officer, a native of North Carolina, was graduated at West Point in 1839, and was appointed the same year lieutenant of Engineers, serving in the United States army, and rising to the rank of major. He resigned at the outbreak of the war, and entered the Confederate army under General A. Sidney Johnston. He participated in the battles of Fort Henry, Donelson, and Shiloh, being wounded at the latter place. Subsequently he rose to be colonel and chief engineer at Richmond; and then, having been ordered to Charleston, he was made major-general and ranked second in command. After the war he made Savannah, Georgia, his home, and there he died Dec. 1, 1883.

<sup>2</sup> *Military Operations*, vol. ii. chapter xxxiii.

it for many days." The commanding general approved their report with emphatic words, as follows :

HEAD-QUARTERS DEPART. S. C., GA., AND FLORIDA, }  
CHARLESTON, S. C., Aug. 26, 1863. }

(*Indorsement.*)

The opinion of Colonel Gilmer and Lieutenant-Colonel Harris of the Engineers is approved. Fort Sumter must be held to the last extremity—*i. e.* not surrendered until it becomes impossible to hold it longer without an unnecessary sacrifice of human life. Evacuation of the fort must not be contemplated an instant without positive orders from these headquarters.

G. T. BEAUREGARD,

*General Comdg.*

As the bombardment progressed the garrison as well as the working force would be actively employed every night, the former in the removal of powder, ordnance, and other stores from the fort; the latter in unloading material for repairs and in preserving shelter for the garrison and itself. Over fifty-six thousand pounds of powder, together with large quantities of shells, loaded and unloaded, were shipped—a delicate and dangerous operation at any time, and particularly so under fire, though at night, it must be said, the fire would be greatly slackened. Yet the crowded, narrow passages within the fort and the hurry at the wharf, together with the always limited transportation by boats, made this part of the garrison's duty to be as arduous as it was important.

Changes, too, were going on in the garrison itself. Colonel Rhett continued in command, with Major Blanding and a few companies; but Lieutenant-Colonel Yates had been transferred to the command of Fort Johnson in the inner harbor. And when it became necessary to relieve all but one artillery company—*viz.* Captain D. G. Fleming's, Company B—detachments of infantry from Colquitt's brigade of Georgians were sent down to the number of one hundred and fifty, under the command of Captain G. W. Warthen. This occurred on the night of the 25th–26th of August, and from that date forward the garrison consisted mainly of infantry, with, usually, one company of artillery.

As the guns of Sumter were becoming dismantled or disabled, sometimes at the rate of five or six a day, they would be more

or less encumbered with the ruined masonry, the splintered woodwork of the carriages, and the heavy irons of the platforms. But, though often completely covered up on the dangerous crest of the shattered walls or protruding through the caving, treacherous slopes of the ruined casemates, these guns, invaluable to the commanding general for the defense of the inner harbor, were never for a moment forgotten by him. As soon as the heavy firing of the first period of the bombardment had slackened, General Beauregard made inquiry about them. Although it was thought at first to be impracticable to remove them under such difficulties, and a report from the artilleryists was so made, yet the general commanding found in John Fraser Mathewes, assistant engineer, a man whose nerve, energy, and perseverance proved equal to the task. On the night of August 27th he began operations with a gang of picked men, and before morning he had thrown down from the parapet, upon a cushion of sandbags laid for the purpose on the berme at the water's edge, two of the heaviest guns in the fort, made ready thus to be removed on a float the next night. Difficulty seemed to him nothing but opportunity. The slippery footing, the crumbling masses beneath the monstrous gun, the labor necessary to raise it, often up the hill of ruins, before it could be prepared to take its plunge of thirty or forty feet down from the top of the wall to the sandbags placed to receive it; then the tedious work of moving the gun from the tide-washed rocks to the float rising and falling with the swell of the sea,—all these were obstacles overcome to the saving of the guns and to the honor of this determined man. Others, encouraged by his success, did as well afterward; but Mathewes began and continued for six months, at intervals, the rescue of these guns from the ruins of Fort Sumter. His merits were promptly recognized and commended in a special order from department headquarters. He was often assisted on the water by an officer and men of the naval force in the harbor. Upward of twenty-five guns and mortars were thus recovered. Lieutenant Julius M. Rhett, First South Carolina Artillery, serving at Fort Sumter, put over the walls for shipment six or seven of the finest guns between the 29th of August and the 4th of September: this was done with

the labor of men from his own company, and deserves to be honorably mentioned.

An accident occurred on the night of the 30th of August, toward the morning of the 31st, which might have proved very fatal and disastrous. Troops sent on board the transport-steamers *Sumter* to relieve the batteries on Morris Island had been successfully landed at Cumming's Point, and the boat was returning to the city by the channel between Sullivan's Island and Fort Sumter, when through some neglect in showing signals she was fired into by Fort Moultrie and speedily sunk. The troops on board were of the Twentieth South Carolina and the Twenty-third Georgia regiments, together with the artillery company of Captain J. Raven Mathewes—in all about six hundred men. Fortunately, the loss was no more than about five men killed, others wounded, and twenty supposed to have been drowned, the great body of them having been rescued by boats sent to their assistance from the Confederate iron-clad steamers *Chicora* and *Palmetto State* and from Fort Sumter. The names of the naval officers who assisted in this work of humanity are not known. The boats' crews from Fort Sumter were made up from the garrison, and commanded by Lieutenants Iredell Jones and Henry M. Stuart,<sup>1</sup> who exerted themselves indefatigably in this volunteer service.

In the operations against Morris Island it has been shown in the previous chapter that the naval force under Rear-Admiral Dahlgren really took a very active and important part. But against Fort Sumter the navy had hitherto done very little. Whether it was an understood thing that the army must deal with the fort and leave the navy to move on the obstructions, or whether a wholesome lesson given on the 7th of April, 1863, was still remembered, cannot now be determined. It appears from the admiral's despatches that he did "attempt to pass the forts" on the nights of the 21st and 26th of August. On the first night he was prevented by the grounding of the *Passaic*; on the second by "bad weather, and chiefly the setting in of a strong flood-tide."<sup>2</sup>

<sup>1</sup> Afterward killed at the battle of Averysboro', North Carolina.

<sup>2</sup> Gillmore, Appendix H.

On neither occasion did he engage the forts. A reconnoissance, with some firing, was made by him about noon on the 31st of August, the Patapsco and Weehawken exchanging shots with Sullivan's Island, and later in the day, when they were joined by the Passaic and Montauk. The rough weather on the night of the 30th again prevented his movement. At last, on the night of the 1st of September, after a very heavy cannonade all day by the land-batteries, the admiral came in, but yet no nearer than DuPont came in daylight on the 7th of April—viz. eight hundred yards off the eastern angle of Sumter and fully a half mile from the dreaded obstructions. But his captains could now with impunity occupy a position from which they had before been driven.

About half-past eleven o'clock six monitors, the admiral having his flag on the Weehawken, took position at from 700 to 1500 yards off the fort and opened heavily upon it. They were joined two hours later by the New Ironsides, coming within 1500 yards, and seen dimly from the fort through a moonlight much obscured by clouds. The guns from Sullivan's Island quickly responded to them, and for five hours the firing was vigorously sustained. In that time the squadron "fired 245 shots and received in all 71 hits; of these the Ironsides fired 50 and received 7; the Passaic was hit seven times, the Montauk five times, and the Patapsco, among several hits, received one severe, penetrating shot on her deck." A round shot from Fort Moultrie, striking the base of the Weehawken's turret, "drove in a fragment of iron, which struck Fleet-Captain O. C. Badger on the leg and broke it short."

Fort Sumter had cause to remember this night-attack. The east wall was now much battered and shaken by the heavy blows of the XI-inch and XV-inch shells thrown by the armored vessels. Every casemate on that side, both upper and lower, was breached, and the filled chambers exposed more or less to view revealed to observers in the fleet the white sand within their recesses. Four shells entered and exploded in these filled chambers, but with little effect. Many others took the western ramparts and casemates in reverse, adding to the ruin already there. But the most dangerous fire was delivered on the western magazine with shells

thrown over the eastern angle and searching the magazine in reverse. Three or four of these were alarming. One burst in the outer passage of the upper magazine, whence all powder had been removed, but sent its blast down the spiral stair-tower into the outer passage of the lower magazine. Both doors of copper being closed no harm was done. Another shell, about to enter the arched passage from the parade to the magazine and hospital, was effectually stopped by the sand-covered blindage erected at its entrance some days before.

Colonel Rhett in crossing the parade had a narrow escape from the bursting of a large shell, which wounded slightly his orderly walking just behind him.

The squadron withdrew at daybreak of the 2d, two of the monitors lingering as if to look for the effects of their fire. This attack upon Fort Sumter, in the time of its duration and the weight of metal thrown at the fort, was twice as severe as that of the 7th of April. But how different the receptions met by the squadron! Instead of a crashing response from Sumter's batteries there was no reply. In grim silence the fort took these blows of assassination, for there was not left now a single gun to fire in its defense. The only two 10-inch columbiads left on the right flank had been put over the shattered parapet the night before, and the garrison detail was preparing to do the same with the XI-inch (Keokuk) gun when the squadron appeared. Being blocked up, out of fighting gear, it could not be used.

The condition of the fort after this severe attack by the iron-clad squadron was worse than ever. Not only had it narrowly escaped an explosion that might have resulted from three shells striking in close proximity to its only magazine then in use, where several thousand pounds of powder yet remained stored, but the actual loss of material, from the battering and disintegration of the eastern scarp-wall in particular, reduced very seriously the chances of protecting the garrison from that direction. True, the fire in reverse which so threatened the magazine had been provided against by careful planning and the completion of massive sandbag work just in time: true, the falling away of great blocks and masses, showered down from

the exterior of the eastern wall when the XV-inch shells would strike and explode, served but to reveal to the observer in the squadron the sand-filling of the upper and lower casemates, finished four months before, and capable now of prolonged resistance; but yet the return, night after night, of such terrible agents of destruction, harassing to the garrison as well as damaging to the fort, was something to be dreaded. Why such attacks were not of regular and frequent occurrence in conjunction with the day firing from the land-batteries, and so the wearing out of the fort and its defenders hastened, as it surely would have been, cannot be conjectured. Perhaps the navy felt all the while that its real mission was to push past those *obstructions*—that the pounding of poor old, battered Sumter after the army had silenced it was as inglorious a work as the bearding of a lion in his den after his teeth and claws had all been extracted.

This night-attack of the monitors and the New Ironsides may well be taken as the ending of the first bombardment of Fort Sumter, occupying, from the morning of the 17th of August to the morning of the 2d of September, a total of sixteen days.<sup>1</sup> There were but few places in the fort at this date that could be called safe: these were four lower casemates of the left or western flank, used for the hospital and head-quarters, adjacent to the south-western angle of the work, both the two lower magazines on the gorge,<sup>2</sup> the splinter-proof blindage on each side of the old sally-port, and two or three casemates of the right face contiguous to the eastern angle. The slope of débris on

	Shot and shell.
<sup>1</sup> Total firing first great bombardment, first period . . . . .	5009
" " " " " second " . . . . .	1819
Total . . . . .	6828

	Killed and wounded.
Total casualties, first period . . . . .	1 k., 42 w.
" " second " . . . . .	1 k., 8 w.
Total . . . . .	2 k., 50 w.

<sup>2</sup> Their "inner faces" were not "battered," as stated by the writer of General Beauregard's *Military Operations*, vol. ii. chap. xxxii.



the exterior of the gorge was practicable for assault, but that on the sea-front was not yet so ; and the filled casemates of that quarter and of the gorge were standing firm and unhurt.

The fort had now lost all offensive character, but it had been firmly decided by the general commanding to hold it in a defensive way to the last extremity ; and it will be seen in the next chapter how well the new policy was inaugurated.

---

*General Orders,* } ADJT. AND INSPECTOR-GENERAL'S OFFICE, }  
*No. 64.* } RICHMOND, VA., August 10, 1864. }

I. The following Roll of Honor is published in accordance with Paragraph I. General Orders, No. 131, 1863. It will be read to every regiment in the service, at the first dress-parade after its receipt :

\* \* \* \* \*

**BATTERY WAGNER, CHARLESTON HARBOR.**

- Captain C. S. Hill, acting chief of ordnance.
- Captain C. E. Chichester, acting chief of artillery.
- Captain J. T. Champneys, acting chief of engineers.
- Sergeant J. T. Respass, Company B, Sixty-first North Carolina troops.
- Private Henry Winemore, Company F, Sixty-first North Carolina troops.

**BATTERY GREGG, CHARLESTON HARBOR.**

- Sergeant J. E. Edgerton, Company A, Twenty-fifth South Carolina Infantry.
- Private E. H. Martin, Company K, Rutledge Cavalry (Fourth South Carolina Cavalry).
- Private W. D. Du Barry, Company E, Charleston battalion.
- Private A. Grimball, Marion Artillery.
- Private F. K. Huger, Company F, Aiken's Partisan Rangers (Sixth South Carolina Cavalry).

The above-named non-commissioned officer and privates are on detached service with the Signal Corps.

\* \* \* \* \*

By order : S. COOPER,  
*Adjutant and Inspector-General.*

## CHAPTER VIII.

### MORRIS ISLAND EVACUATED—FORT MOULTRIE ATTACKED —FORT SUMTER ASSAULTED.

**September 4-9, 1863.**

THE ARTILLERISTS UNDER COLONEL RHETT RELIEVED AFTER THEIR EXHAUSTING SERVICE—HIGH COMPLIMENTS PAID THEM IN GENERAL ORDERS—MAJOR STEPHEN ELLIOTT SUCCEEDS TO THE COMMAND OF FORT SUMTER—HIS GARRISON THE CHARLESTON BATTALION OF INFANTRY—FORT WAGNER'S LAST BOMBARDMENT—THE BESIEGERS APPROACH THE DITCH—ASSAULT IN BARGES MADE ON CUMMING'S POINT QUICKLY REPULSED—THE CONFEDERATES EVACUATE MORRIS ISLAND SKILFULLY AND SUCCESSFULLY—ANTECEDENTS OF MAJOR ELLIOTT, THE NEW COMMANDER—REAR-ADMIRAL DAHLGREN DEMANDS THE SURRENDER OF FORT SUMTER—BEING REFUSED, HE ORGANIZES A NAVAL ASSAULT WITH ARMED LAUNCHES—GENERAL GILLMORE PREPARES ANOTHER FROM MORRIS ISLAND—GROUNDING OF THE MONITOR WEEHAWKEN—SQUADRON MOVES UP AND ENGAGES WORKS ON SULLIVAN'S ISLAND—AGAIN THE NEXT DAY, MORE SEVERELY THAN EVER BEFORE—PREPARATIONS FOR ASSAULT ON SUMTER COMPLETED BY NIGHTFALL—MAJOR ELLIOTT'S DISPOSITIONS FOR DEFENSE—TWO COLUMNS OF BOATS FROM THE FLEET ADVANCE ON THE FORT AFTER MIDNIGHT—THEY ARE MET BY HOT FIRE OF INFANTRY, GRENADES, ETC.—AFTER A STRUGGLE OF TWENTY MINUTES THE BOATS RETREAT, LEAVING A LARGE NUMBER OF THEIR MEN TO BE CAPTURED—EXTRACT FROM THE REPORT OF COMMANDER STEVENS—THE DEFENDERS OF FORT SUMTER AND THE HARBOR MUCH ENCOURAGED BY THEIR SUCCESS.

It need scarcely be said that the duties of the garrison before and during the first bombardment were arduous and fatiguing. Obligated to receive the enemy's fire for sixteen days, with little opportunity of returning it; to work hard, whether under fire or not; to see around them nothing but an hourly increasing destruction; and to feel all the dispiriting influences of the

scene,—they began to suffer from exhaustion and to need relief. Enlisted and disciplined as regular troops, the first regiment of South Carolina Artillery, like the first regiment of South Carolina Infantry, acting as artillery and doing duty on Sullivan's Island, had been brought, under a fine body of officers, to a high degree of soldierly excellence. Much was expected of the command stationed at the most prominent post in the harbor of Charleston and subjected to a severe ordeal. In no spirit of boasting or detraction from the brave defenders of Morris and Sullivan's Islands, or from the troops afterward garrisoning Fort Sumter, the first regiment of South Carolina Artillery may be said to have worthily deserved the commendation of the commanding general.<sup>1</sup> And special resolutions of encomium, passed subsequently by the State, were transmitted to Colonel Rhett as a tribute to himself, his officers, and the men of the garrison of Fort Sumter.

As one company after another would be ordered away to make up the complement necessary for the new batteries arming within the harbor, the regiment must have been loth to turn its back upon the noble fort whose days of strength and order it had so well illustrated, but whose enduring trials of adversity it was no longer to sustain. More than any other officer, the colonel commanding must have felt the stern reality of the change. The fort was no longer an artillery post, and his command was needed elsewhere. On the night of the 1st of September, when the

<sup>1</sup> "HEAD-QUARTERS OF SOUTH CAROLINA, GEORGIA, AND FLORIDA, }  
CHARLESTON, S. C., August 27, 1863. }

GENERAL:

\* \* \* \* \*

The commanding general has witnessed with genuine pride and satisfaction the defense made of Fort Sumter by Colonel Rhett, his officers, and the men of the first regiment of South Carolina Regular Artillery, noble fruits of the discipline, application to their duties, and the soldierly bearing of officers and men, and of the *organization* of the regiment. In the annals of war no stouter defense was ever made, and no work ever before encountered as formidable a bombardment as that under which Fort Sumter has been successfully held.

Respectfully, your obedient servant,

(Signed)

THOMAS JORDAN,

*Chief of Staff.*

To BRIGADIER-GENERAL RIPLEY, commanding First Military District  
S. C., Charleston, S. C.

first bombardment closed with the naval attack on the silent fort, only two companies (B and C) of artillerists remained on duty, the garrison being made up of infantry detachments from the Twenty-seventh Georgia volunteers.

So it happened that on the night of the 4th of September the old gave place to the new order of things. Colonel Rhett was put in command of the inner line of fortifications, while Major Stephen Elliott succeeded to the command of Fort Sumter. At the same time, the garrison was relieved by the Charleston battalion (infantry), 320 strong, temporarily under Major Julius A. Blake, commanding.<sup>1</sup> This command, already distinguished at Secessionville in 1862 and on Morris Island in the protracted defense of Wagner, was made up of six companies—viz. A, Lieutenant James C. Saltus, commanding in absence of Captain W. Dove Walter; B, Captain Thomas Y. Simons; C, Captain James M. Mulvaney; D, Captain J. Ward Hopkins; E, Captain F. T. Miles; F, Captain Samuel Lord. (For Major Elliott's general order on assuming command, see Appendix.)

About this time another change also occurred at the post. Lieutenant John Johnson, who had been engineer in charge since the 7th of April, was on the 2d of September obliged to leave the fort on account of the aggravated condition of a wound received on the 17th of August. For several days F. Marion Hall, assistant, afterward lieutenant of engineers, was in charge until the arrival of Captain J. T. Champneys of the Engineers.

All through the second period of the first bombardment the siege of Battery (or Fort) Wagner was proceeding with greater and greater difficulties.

It has been mentioned that the approaches to Battery Wagner were very much impeded by the sharpshooters stationed behind a low sand-ridge about two hundred and forty yards in advance of the work. Already one effort to dislodge them had failed, and again another, made at dusk on the evening of the 25th, was unsuccessful. At length a sudden bayonet-charge, with large force, on the evening of the 26th, captured the rifle-pits

<sup>1</sup> Its commander, Lieutenant-Colonel P. C. Gaillard, had been recently disabled by the loss of a hand in the defense of Fort Wagner.

there, and secured for the enemy a new and stronger position.<sup>1</sup> But now began, over the remaining distance, the most perilous part of the Federal approach. It became impossible "to push forward the sap in the narrow strip of shifting sand by day, . . . while the brightness of the prevailing harvest moon rendered the operation almost as hazardous by night." For besides the increasing effectiveness of the artillery fire from Wagner and the distant flanking-batteries on James Island, the sappers now encountered "an elaborate and ingenious system of torpedo-mines, to be exploded by the tread of persons walking over them." Sixty loaded shells and water-tight kegs of two gallons' capacity were so placed. Six were exploded by the sappers, with twelve casualties. Yet, though the daily losses were increasing and the progress was almost arrested, such were the powers of the attack, its resources and skill, that the order had only to be issued for the entire weight of army and navy artillery to be brought down upon the devoted little fort to have it perfectly silenced and the siege allowed to proceed to its conclusion. Thus, General Gillmore decided to concentrate on Wagner the tremendous fire of one 10-inch rifle, four 8-inch rifles, nine 6-inch rifles, and ten 30-pounder rifles—in all twenty-four rifle-guns, together with seventeen mortars. These were to be supported by the powerful batteries of the New Ironsides and the other vessels of the armored squadron, adding to the land fire at least twenty more of the heaviest naval guns ever used in warfare. The grand total would reach between sixty and seventy guns and mortars,<sup>2</sup> against Wagner's twelve effective guns.

<sup>1</sup> The larger part of the picket force, about seventy, were taken prisoners; they were of the Sixty-first North Carolina regiment. The charge was made by the Twenty-fourth Massachusetts volunteers, Colonel F. Osborne commanding, supported by the Third New Hampshire volunteers, Captain Randlett commanding, total about 1500, and gave no time for escape, the lines being only some twenty-five or thirty yards apart at one point.

<sup>2</sup> For the week preceding this final bombardment of Wagner the engineer in charge, Captain J. W. Gregorie, reported as follows: "The parapets of this work are in as good condition to-day as at any time since I have been on duty at this post. I consider all the magazines and bombproofs secure from direct or vertical fire—the guns all in working order, except the 10-inch columbiad in the northernmost chamber. It requires a working-party of 200 men every night and 1000 sandbags to keep the fort up to its present standard." The

Accordingly, at daybreak on the morning of the 5th of September all this artillery opened upon Fort Wagner, and in a short while silenced it. The garrison, about 900 men, could not stand to the guns, and betook itself to the best cover to be found. It is a mistake to suppose it was, as a whole, sheltered in the bombproof; hardly one-half could have endured the heat and crowding of those close quarters: a portion, about two hundred, were stationed without and to the rear in the low sandhills affording some natural cover. All that day and night, the day after, and some part of the night following, the garrison, suffering considerable loss and constantly increasing discomforts almost as great as dangers, continued firm in its heroic fortitude under a fire seldom if ever before equalled in severity, and certainly never before directed at so small an object. The land-batteries threw 1663 rifle projectiles and 1553 mortar shells. The New Ironsides contributed 488 shells in the same time, and, together with that of the monitors, the total fire must have been little short of 4000 shots in forty-two hours. In addition to this, a boat-attack, planned to capture Battery Gregg and Cumming's Point in the rear of Wagner, so as to cut off the retreat of the garrison, was made in force on the night of the 5th of September, and signally failed with considerable loss. It was to have been made the night before, but some alarm was given by the musketry firing attending the capture of a Confederate picket-boat, and Battery Gregg was found too ready.

The second attempt was more of an affair, but was not more successful. Colonel L. M. Keitt prepared for it by sending that morning Captain Henry R. Lesesne, First South Carolina Artillery, to take command of Battery Gregg, and by reinforcing the point with infantry after dark. While the troops were taking position two valuable lives were lost, Captain J. R. Haines, Twenty-eighth Georgia, and Lieutenant R. A. Blum, Twenty-fifth South Carolina volunteers, being killed by a mortar shell. Two monitors shelled Battery Gregg heavily from dark till about one o'clock. Then, within a half hour, a column of

armament at this date was fourteen heavy, two light guns, and one mortar. The garrison of Morris Island, for the same period, varied from 1000 to 1500 men.

some twenty barges filled with soldiers and manned by sailors from the fleet was discovered approaching the point through Vincent's Creek, on the western side of the island. Captain Lesesne, waiting for them until they were within one hundred yards of the shore, opened with his 10-inch gun, followed by the howitzers, and the infantry commenced firing shortly afterward. "The enemy returned the fire with their boat-howitzers and musketry. A few succeeded in landing, but quickly returned to their boats. After the fire had been kept up for about fifteen minutes the whole force returned." (Captain Lesesne's report. See *Appendix*.) The Union force was to have been 500, but only about one-third embarked. They were commanded by Major O. S. Sanford, Seventh Connecticut. The artillery of the battery was supported by Major James Gardner, Twenty-seventh Georgia, commanding infantry, and by two field-howitzers stationed to the right of the work, where they were served by Lieutenant E. W. Macbeth, First South Carolina Infantry, "with gallantry and skill."

A calcium light stationed at the left of the second parallel was used by the attack with great success to illuminate the parapet and higher parts of Wagner, so as to deter from any effort at repairing by night the damages of the day. It was hardly necessary. In the effort to repair damages on the night of the 5th, Colonel Keitt reported a loss in killed and wounded of sixty to eighty men of the working-party alone. So plain was the crisis now become that Brigadier-General Gillmore decided to assault the work at nine o'clock on the morning of the 7th, and all preparations were made for that end.

The sappers, though unmolested by the fire of the work itself, were made to suffer by the long-range fire of the flanking-batteries on James Island until the approach became so near as to endanger the garrison. This period was reached when the sap was about to push by the south face toward the close of the second day. Thenceforward the sappers had nothing to fear, not even any longer the torpedoes; but, entirely under cover of the east or sea-front, they advanced nearly to the flank of that front, where they finished their labors and entered the ditch about ten o'clock that night (September 6th).

As might have been expected, the effect of such a bombardment (forty-two hours) was to damage the work more seriously than ever before, to put an entire stop to all repairs, and to disable guns. But, though neither the magazine nor the bombproof quarters for the garrison had been breached, the endurance of the sturdy little fort was finally coming to be questioned. Lieutenant-Colonel Harris, chief engineer, visited the island under the fiery storm of the 6th with special orders from General Beauregard to inspect damages and give his opinion. He advised its immediate evacuation, and orders were issued to Colonel L. M. Keitt, commanding at Battery Wagner, about 4 P. M., to effect it that night. This very delicate and critical operation was carefully planned at head-quarters, and carried out with almost perfect success. The two Confederate iron-clads assisted with their boats, under Lieutenant W. H. Ward, of the Palmetto State, together with Lieutenants C. L. Stanton, C. H. Hasker, and W. H. Odenheimer; and Colonel Keitt, ably sustained by Lieutenant-Colonel O. M. Dantzler, Twentieth South Carolina, in charge of transportation, by Lieutenant-Colonel J. G. Pressly, Twenty-fifth South Carolina, and Major Henry Bryan, A. A. General, had the satisfaction of completing the movement shortly after midnight. Two or three boats containing forty-six soldiers and sailors under Lieutenant Hasker were captured by the Union pickets. (For Colonel Keitt's full report and Captain Huguenin's graphic journal see Appendix.)

Thus terminated the siege of Battery Wagner, memorable for its duration of fifty-eight days, for the persevering skill displayed in the attack, and for the sturdy resistance of the defense. History will promote it from a battery to a fort, but it was always known to the Confederates as "Battery Wagner." In conjunction with Battery Gregg at Cumming's Point, it had repulsed three assaults of the enemy, and stood without any serious damage to the last one of the heaviest bombardments on record. (For a tabulated statement of details, see p. 273, "Résumé and Conclusion.") The highest compliments were paid to the commander of the Union forces by his superiors at Washington.<sup>1</sup>

<sup>1</sup> "General Gillmore's operations have been characterized by great profes-



And yet the Confederates were not without their satisfaction also in having made a stand for the protection of Charleston that availed them to the end of the war. For the conquest which they left to the enemy was fruitless; the barren island was but a barren trophy.

The hardships of defense in Wagner were certainly greater while they lasted than those endured in Sumter. They have been well described by Major Gilchrist in the *Charleston Year-Book* (1884), an extract from which is given in the note below.<sup>1</sup>

sional skill and boldness. He has overcome difficulties almost unknown in modern sieges. Indeed, his operations on Morris Island constitute a new era in the science of engineering and gunnery." (Report of Major-General Halleck, general-in-chief, 15th of November, 1863.)

<sup>1</sup> "From the 20th of July was a period of simple endurance on Morris Island. Night and day, with scarcely any intermission, the hurtling shell burst over and within it. Each day, often from early dawn, the New Ironsides or the monitors, sometimes all together, steamed up and delivered their terrific broadsides, shaking the fort to its centre. The noiseless coehorn shells, falling vertically, searched out the secret recesses, almost invariably claiming victims. The burning sun of a Southern summer, its heat intensified by the reflection of the white sand, scorched and blistered the unprotected garrison, or the more welcome rain and storm wet them to the skin. An intolerable stench from the unearthed dead of the previous conflict, the carcasses of cavalry horses lying where they fell in the rear, and barrels of putrid meat thrown out on the beach, sickened the defenders. A large and brilliantly colored fly, attracted by the feast and unseen before, inflicted wounds more painful, though less dangerous, than the shot of the enemy. Water was scarcer than whiskey. The food, however good when it started for its destination, by exposure, first on the wharf in Charleston, then on the beach at Cumming's Point, being often forty-eight hours *in transitu*, was unfit to eat. The unventilated bombproofs, filled with the smoke of lamps and the smell of blood, were intolerable, so that one endured the risk of shot and shell rather than seek their shelter.

"The incessant din of its own artillery, as well as the bursting shells of the foe, prevented sleep. . . . The casualties were not numerous, and yet each day added to the list of killed and wounded. Amputated limbs were brought out from the hospital and buried in the sand. Often bodies followed them. Only as a special favor, or where high rank claimed the privilege, were the dead carried to the city for interment. There were few in the battery who could not tell of some narrow escape where a movement of position only had saved life. Nor can we specify the instances of personal heroism where all were brave: so often was the flag rescued and remounted that orders were issued by the commanding general forbidding it; flags were many, but men were few. Thus the days lengthened into weeks, the weeks into months, while

After the 17th of August, when the breaching-batteries of Morris Island were opened on Fort Sumter and its demolition assured, the holding any longer of the northern end of the island by the Confederates might appear to have been an unnecessary effort. General Gillmore says truly: "Neither Fort Wagner nor Battery Gregg possessed any special importance as a defense against the passage of the iron-clad fleet. They were simply outposts of Fort Sumter. Fort Wagner, in particular, was specially designed to prevent the erection of breaching-batteries against that work. *It was valueless to the enemy if it failed to accomplish that end*, for the fleet in entering was not obliged to go within effective range of its guns." Why, then, it may be asked, was the northern end of Morris Island held by the Confederates for three weeks after it had been demonstrated that Wagner was valueless to them as an outpost of Sumter? The answer is, General Beauregard estimated it, if no longer an outpost of Fort Sumter, as indeed an outpost of the city of Charleston, and he held it long enough to enable him to gain three weeks in perfecting the defenses of James Island and the inner harbor.

The strategy of the Confederate commander, determined by the difficulty of maintaining communications with Cumming's Point, appears to have been rather to keep the Union army

the brave and patient defenders individually stood face to face with death and endured in many instances what was worse.

"Nor was the garrison inactive. For the blows received blows were given. Several monitors retired worsted from the encounter, and were not seen again. Explosions in the advancing works of the enemy showed the accuracy of the Confederate fire; while every night, through the weary hours lengthening into new days, the working-parties swarmed over the fort to repair the damage done to bombproof, parapet, and traverses. Fighting from early morn to set of sun, and working through the livelong night, comprised their sum of life and daily experience.

"It was not possible for human endurance to stand this mental and physical strain long. As each command became exhausted it was relieved, and fresh troops took its place. Six days was the longest period of any command; the infantry served only three days at a time. And no greater proof can be had of their courage and devotion than that, with personal knowledge of the perilous nature of the service, the same commands returned time and again, with full ranks, and even greater *esprit de corps* as the fierce struggle grew more intense."

occupied with the struggle for Morris Island than to contest its advance *in that quarter* with much seriousness. A diversion from the unfinished defenses of James Island and the inner harbor was to his mind so desirable an object that to gain it he gave up the outlying works of Morris Island with little hesitation after having derived from them for Charleston the benefits they failed to give Fort Sumter. He appears to have thought, If an army must threaten Charleston it had better be allowed to operate on the exterior, in the long *cul-de-sac* of Morris Island, than on the interior in the broad and spacious ranges of James Island. No one will deny that the sequel justified this opinion. With this principle of defense kept in view, it may be candidly admitted that in two particulars, pointed out by General Gillmore, the special defense of Battery Wagner was faulty—viz. the disuse of vigorous night-sorties and of mortar-firing. From numerous admissions in the reports of Federal officers, it is plain that if even the single mortar occasionally fired from Wagner had been well served upon the sappers they would have been seriously delayed ;<sup>1</sup> while, if the Confederates had mounted four or five mortars to the rear of the gorge under cover of its parapet, and had served them with any spirit, it is highly probable that the approach of a sap over that narrow front could have been entirely arrested, notwithstanding the immense preponderance of the enemy's artillery.

Now that Morris Island was evacuated and destined before long to be fortified by the Federals up to the northern limit, Cumming's Point, it became evident that Fort Sumter was more than ever on "the perilous edge of battle." Henceforth it was to be the nearest of all the forts and batteries to the enemy. From having been a citadel, it had become an exposed outpost, an advanced work in ruin. Brave officers, who had watched it day by day crumbling under the heavy fire and losing all its fair proportions, grew disheartened at the sight, and gave it as their candid military opinion that the holding of it any longer would be impossible or would amount to a mere sacrifice of the garrison. But this was little in accord with the mind and purpose of General Beauregard. He had from the first opening of the

<sup>1</sup> See Gillmore, pages 213-216.

bombardment determined to withdraw the artillerists from the work, and to supply their place with infantry ; but he kept it a profound secret, not wishing to discourage or reflect upon the old garrison, composed of as true and gallant officers and men, from their colonel down to the last private, as he had ever seen.

The decision of the commanding general to hold Fort Sumter with no thought of surrender was received with enthusiasm by the people of South Carolina, and generously adopted by her sister States of the Confederacy. The defense assumed from this time greater importance than ever. Pride and sentiment were enlisted in it. The military spirit of the troops around Charleston was stirred and stimulated. The fort was henceforth regarded as the post of honor.

It has been mentioned in this chapter that the new commander, Major Stephen Elliott, entered upon his duties only two days before the evacuation of Morris Island. This officer, at the earliest period of the war captain of the Beaufort (Light) Artillery, saw his first service in November, 1861, when Commodore DuPont captured the forts at Port Royal Entrance, South Carolina. Later, in the next year, he took an active and prominent part with his light battery in the repulse of the Union force at Pocotaligo in the same vicinity. With his superior officers he stood well ; and General Beauregard, from knowing him personally and hearing his good report for gallantry and self-reliance, sent for him. Being asked by the general if he was willing to assume command of the ruins of Fort Sumter on condition that his garrison should be limited to a certain number, and that the Federal flag should never be seen floating over the spot while the department was under himself, Major Elliott's eyes brightened, and he answered the general that he would be happy to do so. He was then told that before making his definite answer he would be expected to go there for twenty-four or forty-eight hours to know *exactly* "what he would be ordered to encounter." He went, and returned in less than twenty-four hours, saying that he was "anxious to have the position," and that he "would carry out my instruc-

tions or die in the attempt. His orders were given him at once."<sup>1</sup>

Having been informed before daylight of the 7th of September by Brigadier-General Gillmore that the Confederates had evacuated the island, the rear-admiral sent in a flag of truce demanding the surrender of Fort Sumter. It was met by a boat from the Palmetto State,<sup>2</sup> and the demand taken by the officer in charge, Lieutenant Robert J. Bowen, C. S. N., to Major Elliott, commanding, about 8 A. M. The answer sent was that a definite reply would be returned as soon as he could communicate with the commander of the department. The definite reply came in these terms: "Inform Admiral Dahlgren that he may have Fort Sumter when he can take and hold it."

Captain F. T. Miles of the Charleston battalion was the bearer of the reply from Fort Sumter, and was, through some misunderstanding, fired upon repeatedly by the batteries on Sullivan's Island. He resolutely persisted, however, in his course, and the fire after a time ceased. The rear-admiral had told both Brigadier-General Gillmore and the Secretary of War that he meant to follow up the demand, if refused, by instantly moving on the fort and obstructions with all his vessels. But this purpose was changed on second thought, and another substituted for it—viz. a night-assault with marines and sailors in launches from the fleet.

Several events of interest occurred before the new project could be tried. While the messages by flag of truce were in

<sup>1</sup> The above is from a private letter written by General Beauregard to the author, dated September 10, 1869. Major Elliott (born 26th of October, 1830) was at the time of assuming command of Fort Sumter about thirty-three years old. He was promoted to be lieutenant-colonel in November, 1863. He continued in command of the fort until ordered to Virginia in command of a regiment, May 4, 1864. Serving chiefly in front of Petersburg, he soon (20th of May) arose to be brigadier-general; was severely wounded at the "Crater fight;" returned to South Carolina and commanded a brigade in the battles of Averysboro' and Bentonville, North Carolina. His health failing after the war from the effect of his wound, he died in Aiken, S. C., February 21, 1866.

<sup>2</sup> General Beauregard had some days before asked Flag-Officer Tucker to take position with his iron-clad vessels between Battery Bee, Sullivan's Island, and Fort Sumter.



Brigadier-General STEPHEN ELLIOTT, P. A. C. S.  
Commanding Fort Sumter 1863-64.  
From a Photograph.



transmission the monitor Weehawken, Commander E. R. Colhoun, was carrying out some order when she grounded in eleven feet of water in the narrow channel between Fort Sumter and Cumming's Point. This was on the morning of the 7th and on the ebb of the tide. Efforts to get her off at high water in the afternoon failed, although the accident did not become known to the Confederates until the next morning. Meanwhile, the rear-admiral ordered the New Ironsides and the monitors to move up about 6 P. M. and engage the batteries of Sullivan's Island. This they did heavily, the Ironsides alone firing 152 shots at Fort Moultrie and receiving a severe return, the Patapsco also being badly damaged by Battery Bee; the Weehawken being present, but fast aground. The firing ceased when it grew too dark to see, about nine o'clock, and the vessels retired to render all possible assistance to their disabled comrade.<sup>1</sup>

The lookout from Fort Sumter discovered early the next morning (8th of September) what the condition of the Weehawken really was, and Major Elliott soon communicated the intelligence to the other posts. By half-past eight o'clock Fort Moultrie, distant 2000 yards, opened upon the stranded monitor, now exposing nearly the third part of her hull above water; Battery Bee joined in the firing, and Battery Simkins also, from Shell Point, James Island, sent compliments to the same inviting object. But, though dangerously exposed, the monitor was neither disabled nor non-combatant. So far from it, Commander Colhoun made a very gallant fight under all his disadvantages. The second shell fired by him at Fort Moultrie from his XV-inch gun<sup>2</sup> "struck the muzzle of an 8-inch columbiad and glanced into some shell-boxes," producing an explosion that killed sixteen and wounded twelve men of the garrison;<sup>3</sup> and altogether in the course of the day the doughty officer fired eighty-two times at Sullivan's Island and Fort Sumter. But

<sup>1</sup> Colonel William Butler, commanding the artillery, reports the loss of First Lieutenant E. A. Erwin at Beauregard Battery, killed in this engagement.

<sup>2</sup> *Armored Vessels*, Ex. Doc., page 235.

<sup>3</sup> Colonel Butler's report, September 12, 1863, Appendix.



his escape from destruction was due to the diversion made in his favor by the other vessels of the squadron ; for his monitor was hit twenty-four times, and the damages required sixteen days for repair : three of the crew were wounded ; the vessel was got afloat again about 4 P. M. (See Appendix to this chapter.)

The diversion made by the rear-admiral to cover his endangered monitor began about 11 A. M., and led to what was probably the severest naval engagement in American history up to that time. The *New Ironsides*, together with the *Patapsco*, *Lehigh*, *Nahant*, *Montauk*, and *Passaic*, came to anchor from 1400 to 900 yards distant from Fort Moultrie, and for nearly three hours delivered by far the heaviest cannonade heard from the naval force off Charleston harbor. The Confederate works suffered no damage of much importance : of about thirty engaged, two guns were dismounted, and, mainly, the casualties were those already mentioned in connection with one shell fired by the *Weehawken*. The total killed were 19, and wounded 27 ; among the latter was Lieutenant D. B. DeSaussure.

To a looker-on from Fort Sumter that day the Federal navy seemed to have altogether the best of it ; for the stranded monitor got off with flying colors, and the Confederate batteries appeared to be silenced more than once. Colonel Butler, commanding the artillery on Sullivan's Island, reported that his fire was weakened on account of the scant amount of ammunition on hand. Nevertheless, the fight made by both sides was equally determined if not equally furious. Captain S. C. Rowan, who commanded the *New Ironsides*, testified in his report : "The fire of the forts slackened down to an occasional gun, when I directed a slow fire kept up to economize shell. The moment the enemy discovered this he jumped from behind his sandbags and opened rapidly. I renewed our rapid fire and silenced him again." (*Armored Vessels*, page 240.)

In fact, this ship never did so well before or after : her powerful batteries of XI-inch guns thundered with a rapidity and a weight of metal that far surpassed the fire of the monitors. She fired 183 rounds, was hit 70 times, and yet her captain thinks of no damage worthy to be reported.

The effect of the explosion of that pile of loaded shells in

Fort Moultrie must have been terrible and trying in the extreme. Nearly all of Captain R. Press Smith's company were killed or wounded by it,<sup>1</sup> the captain himself narrowly escaping by leaping into the ditch in front of the fort. To supply its place, another company of the same regiment (First South Carolina Infantry, regulars), under the command of Captain Burgh S. Burnet, was led, under the severe fire, from Battery Beauregard to Fort Moultrie, a distance of about eight hundred yards. (See Confederate reports in Appendix to this chapter.)

Two circumstances remain to be wondered at in the chronicle of this engagement. One is, that the Confederate gunners suffered the Weehawken to escape; and the other is, that the Federal squadron did not push on past the batteries up to and beyond the obstructions. To the close of the war the obstructions appeared to be more dreaded by the navy than the batteries which commanded them. The squadron never again made such an attack as this of the 8th of September. It must be said, however, that the obstructions of rope-nettings with torpedoes at this date were incomparably superior to those without torpedoes on the 7th of April of the same year, when Fort Sumter was attacked by Rear-Admiral DuPont, and Captain John Rodgers in the lead declined to use his torpedo-raft upon a threatening array of floating beer-barrels. The moral effect of these invisible dangers will always be felt in torpedo-warfare, whatever may be the provision made to meet them;<sup>2</sup> but it is very strange that the nature of those at the entrance to Charleston harbor, together with their constantly recurring derangement and inefficiency, continued for nearly two years undiscovered by the United States navy.

It appears from the *Diary* of Rear-Admiral Dahlgren that while the iron-clad squadron was so heavily engaged with Fort

<sup>1</sup> A parallel occurred in the Union batteries on Morris Island, July 25th of the same year. General W. W. H. Davis mentions the wounding of twenty-one men by the exploding of a Confederate shell "in the midst of a fatigue-party mounting a 200-pounder." The same officer is authority for stating the fact that nine men in the trenches were killed by the bursting of one shell fired from James Island, August 27, 1863.

<sup>2</sup> Some one has well described the torpedo as being a weapon which attacks both matter and mind.

Moultrie and the supporting batteries, he was engaged, then and "all day, arranging to assault Sumter." The expedition, composed of five divisions of boats carrying four hundred and fifty picked men, was organized from the blockading fleet of wooden gunboats. It embraced one hundred marines, and the rear-admiral reported that "great care was taken in organizing the column of attack: there were no better men on hand, and they were led by officers whose standing fully justified their selection." The whole was put in charge of Commander T. H. Stevens.

Late in the day, September 8, 1863, when the admiral sent to borrow some boats from General Gillmore, it became known to the navy that the army also was preparing for a like assault the same night. Concert of action was thereupon arranged, or at least was supposed to be arranged, on the authority of Lieutenant Preston reporting to the admiral. But the two attacks were yet to be each under its own leader. Simultaneously with the thronging and jostling of launches, cutters, and steam-tugs outside among the fleet there was a crowding of barges in Vincent's Creek, west of Cumming's Point, where the army was making its rendezvous. With two small regiments General Gillmore thought his force strong enough without the co-operation of the naval column, but he evidently distrusted the want of unity in attack, and, as the event proved, took no part in it.<sup>1</sup>

Meanwhile, orders had been given in the fleet for the boats to assemble by 10 P. M. alongside of the tug expected to tow them up within eight hundred yards of the fort. It was not until after twelve o'clock that they reached the station, and were cast off apparently in some disorder, haste, and confusion. The night was uncommonly dark, and favored the defense, apparently, as much as the attack; for the plan of having one division to move in and around to the north-western front of

<sup>1</sup> From Judge Cooley's book, page 109:

SEPTEMBER 8TH.

ADMIRAL DAHLGREN: I deem it of vital importance that no two distinct parties should approach Sumter at the same time, for fear of accident. I will display a red light from the fort when taken; I ask you to do the same if your party mounts first. Our countersign is "Detroit;" let us use it in challenging on the water.

(Signed)

GEN. GILLMORE.

the fort by way of a diversion, while another column should advance on the south-eastern front of the fort, was all deranged by haste and darkness. Not more than two divisions out of five seem have taken part in the actual landing at the fort.

Major Elliott had become quite possessed with the idea of an assault by night, and had protested on the morning of the 8th against a threatened reduction of his force. He further procured that day from the city a full supply of hand-grenades and fire-balls. The dispositions customarily made for each night at this period were as follows: Captain Hopkins's company, forty-three men, lay on their arms on the crest of the gorge, that being approached by a practicable slope from the water's edge: in case of alarm the right of this line was to be supported by Captain Lord's company, forty-two men, occupying the rampart of the south-western angle; the left of the gorge-line was to be supported by Lieutenant Saltus with a small detachment of his company. Lieutenant Harris, with twenty-five men, was assigned to the north-east angle, being the left of the sea-face, at that time not presenting a practicable slope, as it subsequently did, but showing a number of breaches into the casemates, which had been filled with sand months before. There was a formidable breach on the north-western face, and there Captain Miles was stationed with his company. Captain Mulvaney was to support him, and Captain Simons was assigned to the defense of the western casemates and the wharf. Detachments in charge of Signal-Officer F. K. Huger were posted at three points on the wall to throw hand-grenades and fire-balls. The old stone wharf on the gorge was mined and made ready for instant explosion.

It was one hour after midnight when Major Elliott, on the lookout himself, had his attention directed by a sentinel to a line of barges advancing toward the north-eastern angle, and soon after a second line was discovered moving upon the south-eastern angle. With the coolness of a veteran the commander cautioned the sentinels not to fire; then, placing men in position along the ruined parapet of the sea-face, he put Captain Hopkins in charge of these, in addition to his own company on the crest of the gorge, and ordered up three other

companies within supporting distance. By this time a division of boats under Lieutenant E. P. Williams was advancing on the north-eastern angle with considerable dash, and began to deploy preparatory to landing. Orders had been given to reserve the fort's fire until this moment, and when the leading boats were in the act of landing they were surprised by a rapid and effective discharge of rifles and hand-grenades. The outer boats, filled with marines, replied rapidly for a few minutes. The sailors who had effected a landing fired a few times from their revolvers, but for the most part sought refuge from the galling fire in the embrasures and breaches or under the large masses of débris at the base of the wall, only to be dislodged by the searching of hand-grenades and fire-balls, and even by the throwing down of fragments of the brick masonry from the parapet. The other division of boats observed to be advancing on the south-eastern angle was under the command of Lieutenant G. C. Remy. It seems that only two boats of this division ever touched the fort, and they, finding themselves unsupported, soon pushed off and joined their wavering or retreating comrades.

But the rattling fire of infantry from the walls of Fort Sumter had already given signal to the batteries of James and Sullivan's Islands and to the iron-clad gunboat *Chicora* stationed north of the fort. These allies opened with all promptness in the dark night, guided by the fringe of fire on the sea-front of the fort, and chiefly by their own lines for pointing, established by careful practice in the day-time. Shot, grape, canister, and shell were thus sent ricocheting and exploding along the water at the base of the fort on three of its exposed fronts, and must have contributed in some measure to the dispersion of the flotilla. For dispersed it was indeed by this time. The attack had been a feeble one, and it was all over in twenty minutes. The following abstract from Commander Stevens's report will make this clear :

“Lieutenant Higginson was directed to move up to the north-west front of the fort with his division, for the purpose of making a diversion, while the remainder of the divisions were ordered to close up and wait for the order to advance upon the south-east front. My intention was

to wait until we had the full benefit of the diversion Lieutenant Higginson was directed to make in our favor; but, mistaking his movement, doubtless, as intended for a general one, and in that spirit of gallantry and emulation which characterizes the service, many of the other boats dashed on; finding it too late to restrain them, the order was given to advance. As soon as the boats were discovered they were met with a fire of musketry, hand-grenades, lighted shells, and grape and canister; and simultaneously, at a signal from the fort, all the enemy's batteries surrounding us, with one of their gunboat rams, opened fire. Several of the boats had by this time effected a landing, but the evidences of preparation were so apparent, and the impossibility of effecting a general landing or scaling the walls so certain, that orders were given to withdraw. All who landed were either killed or taken prisoners, and serious casualties occurred in the boats near the fort."

Among the officers here captured were Lieutenant-Commander E. P. Williams, who afterward perished with the ill-fated *Oncida*; Lieutenants S. W. Preston and B. H. Porter, who were killed at Fort Fisher, the former of whom was attached to Admiral Dahlgren's staff; also Lieutenant C. H. Bradford, marines, mortally wounded, and Lieutenants G. C. Remey and E. G. Dayton. Not a man in Fort Sumter had been hurt. The Federal loss was 6 killed, 2 officers and 17 men wounded, and 25 missing, while 10 officers and 92 men, with five launches, were captured and sent up to the city; total loss, 124.

The prisoners told Major Elliott that they scarcely expected any resistance, it having been generally concluded in the fleet that the breaches seen in the wall of the sea-front were easy of access from the base of the fort and afforded direct communication with the interior. When they came to examine for themselves, they found those breaches easy of access, but impenetrably stopped with twenty feet thickness of white sand. Looked at from the fleet, these fillings of the lower casemates appeared as blank openings in the dark brick wall, and ready to admit all visitors by day or night. But the great mistake of the assault was in not attacking on the side of the gorge, where a practicable slope, though of very rough footing, would have favored them. Had two divisions of the boats made that their place of landing, or, better still for the Federals, had General Gillmore's assault with troops from Vincent's Creek west of Cumming's Point

been made in concert with the naval attack, so that while the latter was occupying the garrison on the northern and eastern fronts, the former could have threatened the gorge, there might have been a very different result for the fort. As it was, the easy victory of the Confederates confirmed them in their resolution to hold their ground to the last. The repulse of this boat-attack was felt to be a reassuring event in the history of the fort, as well as a new honor worthily to be borne by its brave defenders.

## CHAPTER IX.

### THE SECOND GREAT BOMBARDMENT OF FORT SUMTER.

September 9 to December 6, 1863.

THE FORT, IN A RUINED CONDITION, HELD AS THE OUTPOST OF THE HARBOR—GENERAL GILLMORE FORTIFIES THE NORTHERN END OF MORRIS ISLAND—FORT SUMTER'S RESPITE OF SIX WEEKS—THE FIRST MINOR BOMBARDMENT—BOMBPROOF QUARTERS CONSTRUCTED, AND THREE HEAVY GUNS MOUNTED IN CASEMATES OF NORTH-EASTERN FACE—OPENING OF SECOND GREAT BOMBARDMENT, OCTOBER 26TH—MORTAR SHELLING FOR THE FIRST TIME—THE MONITORS ASSIST THE LAND-GUNS—FREQUENT CASUALTIES—LOSS OF A WHOLE DETACHMENT BY FALLING OF BARRACKS—THE EXTERIOR SLOPES REQUIRE OBSTRUCTION AGAINST ASSAULT—THREATENED ASSAULTS DISCOVERED—CALCIUM LIGHT THROWN UPON THE FORT—INTERIOR OF THE FORT ARRANGED FOR LOOPHOLE FIRING—DEATH OF CAPTAIN HARLESTON—THE FLAG-STAFF SHOT AWAY, AND REPLACED WITH GALLANTRY ON SIX OCCASIONS—SECOND GREAT BOMBARDMENT ENDS DECEMBER 5TH—IT RESULTS IN CHANGE OF DIMENSION AND LOSS OF MATERIAL—STATEMENT OF SHOTS RECEIVED AND CASUALTIES SUFFERED—INCREASED DETERMINATION ON PART OF DEFENSE.

MAJOR ELLIOTT had now demonstrated to both friends and foes that Fort Sumter could not be had for the asking. The repulse showed, by the vigilance and spirit of the garrison and by the concentrated fire of the harbor-batteries and gunboats, that the fort could have been equal to a much severer test of its strength. Yet, with all the encouragement growing out of this latest success, there came the irrepressible thought that Fort Sumter was still in an exceedingly critical condition. With scant and most uncomfortable quarters, the garrison and working force might be subjected at any moment to the shelling of land guns by day and naval guns by night, calculated to harass the work-



ing-parties, exhaust the garrison, and ruin entirely the few remaining hiding-places.

But properly to appreciate the actual condition, as well as appearance of the fort, it will be necessary to consult the illustrations of this date, and bear in mind the explanations which, it is hoped, will make them to be understood.

During the heavy cannonade of Sullivan's Island by the iron-clad squadron on the 8th of September an artist from Charleston, Mr. G. S. Cook, was engaged in taking photographs of the interior of Fort Sumter. A comprehensive view of the interior was obtained by him from a point in the parade looking northward to the chief salient. Beginning on the left, one sees the upper casemates of the northern half of the western or city front open and exposed to the naval fire coming over the eastern wall. The western barracks are nearly levelled to the first story. The parapet and terreplein are badly cut up and shattered. The single gun in barbette is pointing toward the city, and is at the north-western angle. The next feature that arrests the eye, moving to the right, is the large breach in the scarp-wall of the north face. This breach gives a good idea of the destructive power of the long-range and heavy Parrott rifle-guns used by General Gillmore from Morris Island, and taking this face of the fort in reverse. It grew to its present size from an enlargement of one of the closed embrasures of the upper casemates, and its prominence beyond all other places damaged, except a corresponding breach on the gorge-wall, was due to its being on the line of fire from Morris Island, which passed *centrally* through the fort, and so marked the passage of the greatest number of projectiles discharged at the fort from that particular direction. It indicated, so to speak, the converging aim or focus of all the breaching-guns as they were, from all positions on Morris Island, trained upon the mass of the fort. The northern angle or principal salient is marked by the open and ruined stair-tower, narrower than any of the casemate openings. Centrally in the parade a shell has just fallen and burst, after having passed over the gorge-wall, discharged by the monitor Weehawken aground most of this day off Cumming's Point, but firing as many as forty-six times at Fort Sumter. To the right





of the shell are some uninjured casemates, of which the upper ones were in a month or two destroyed, but of which the lower ones continued to be used, and even armed, to the end of the Confederate defense, their guns bearing on the channel nearly opposite to Fort Moultrie. On the ramparts is seen the flag, flying temporarily in that position close up against the brick traverse erected almost a year before to protect the barbette guns of the north-east front from a naval fire. The view is closed on the right by the eastern barracks, having their third story and interior very much damaged. It was in one of the lower rooms of these barracks that later a fatal accident occurred through the falling of the ruins upon a detachment of sleeping soldiers.

By eight o'clock of the morning after the assault the rear-admiral sent in a flag to communicate with Fort Sumter. It was met and declined until explanations were made concerning a recent firing upon a Confederate flag. Then it appears from Major Elliott's journal<sup>1</sup> that two flags were sent from the fleet on the 9th. The second, about 4 P. M., brought "baggage belonging to the captured officers and conveniences for the wounded." In return, a flag from the fort, about 6 P. M., conveyed to the fleet the bodies of its dead. On the same day the commander and his garrison were warmly complimented on their brilliant success by a despatch from General Beauregard.

Looking down from the walls of Fort Sumter on the shores of Morris Island, one could not help seeing the changes that were going on at the northern end. The Federals, allowing themselves a little time to admire the solidity of the captured works,<sup>2</sup> began actively to transform them and turn them upon

<sup>1</sup> In the *Memoir of Dahlgren* no entry whatever appears in his diary between the 8th and 13th of September.

<sup>2</sup> Major-General Gillmore reported Wagner "a work of the most formidable character," and its bombproof "remained practically intact after one of the most severe bombardments to which any earthwork was ever exposed." (*Operations*, page 74.) His chief of staff and artillery, Brigadier-General J. W. Turner, said the same: "Notwithstanding the heavy fire of this bombardment, together with all the fire Fort Wagner had been subjected to since the commencement of our attack from land and naval batteries, its defenses were not materially injured." (*Operations of Gillmore*, Appendix.)

their late defenders. During the six weeks spent by them in accomplishing these changes their working-parties could be seen all day and heard by night busily engaged, in disregard of the fire of James and Sullivan's Islands. Occasionally a well-directed shot would be seen to take effect among the men or teams employed, but as an observer watched these determined and persistent laborers it was felt to be exceedingly mortifying that no more opposition could be made to their advance. Scarcity of ammunition was the reason given for the slack firing of the Confederates, and the ranges were extreme for their smoothbore guns.<sup>1</sup> But with this picture of unmolested hostility under his eyes for more than a month, Major Elliott could report very significantly to head-quarters: "The working-parties (on Morris Island) suffer greatly from the want of being shelled."

By the third week in October the armament was nearly ready in the new batteries of Morris Island. Fort Putnam was the name given to Fort Wagner; Battery Strong took the place of Battery Gregg; and a third, Battery Chatfield, was constructed at a point nearly midway between the captured works, while near the southern end of the island Fort Shaw was built. Up to this time no mortars had been used by the attack against Fort Sumter. But henceforth they were to enter largely into the bombardment. As many as sixteen mortars, among them two of 13 inches, the remainder of 10 inches, together with a total of twelve Parrott rifles, 100-, 200-, and 300-pounders, and one 10-inch columbiad, making a total of 29 guns and mortars, were mounted for the next grand effort. Besides this heavy

<sup>1</sup> Unexpected testimony to the accuracy and effectiveness of this fire is given by General W. W. H. Davis: "At times the accuracy of the enemy's fire was wonderful when we consider the distance. In one period of twenty-four hours, out of 235 shells fired at Wagner, 185 burst inside the fort, killing and wounding sixteen men. Another day 150 shells struck inside the same work. Now, when we consider that the guns which fired these shells were at the distance of about two miles, and that the space they were dropped within embraced an area of less than an acre, we must come to the conclusion that the shooting was remarkable." (*History One-Hundred-and-Fourth Pennsylvania.*)

"We were near enough Charleston to tell the time of day by their clocks on the church-steeple, and people could be seen walking in the streets. The workmen on a new iron-clad at the wharf were plainly to be seen with a glass." (*Ibid.*)

artillery, there were several rifled pieces of the 30-pounder class.

The garrison in Fort Sumter had been enjoying a relatively long season of quiet, for, with the exception of six days at the end of September, they were unmolested for nineteen days prior to that, and for twenty days after that firing. The six days' firing (September 28th to October 3d) was a minor bombardment, the first of its kind. The aggregate shots fired were 567; the casualties were 1 killed and 1 wounded. The damage was hardly perceptible. Practically, the garrison had the opportunity given it during six weeks to improve its condition, and it did so. The need for more bombproof accommodation than the few remaining casemates could afford was felt to be urgent. Accordingly, by covering in the vacant archway of the old sally-port in the gorge, ventilating and connecting it by galleries with the parade on the interior of the fort, the engineers provided additional quarters for one hundred men.

Major Elliott had not been three weeks in command before he wrote to Brigadier-General Ripley at head-quarters of the military district, urging that he should be allowed to put the fort again on at least some footing of offensive strength. His letter, copied from his post-book, will be found in the Appendix of this chapter.

Four of the lower casemates on the north-eastern front, next to the eastern angle, had been so covered from the Morris Island batteries by the mass of the sea-front as to escape with but little damage from reverse fire, though they had been injured externally by the monitors. It was advised that these casemates should be now made perfectly secure against the fire in reverse by throwing up a massive protection of sand and débris, so as to close their arches opening on the parade, and then that they should be armed with heavy guns to cross fire with the batteries of Sullivan's Island bearing on the channel and guarding its obstructions. After inspecting with particular care the condition of the piers and arches, the engineers pronounced favorably on the plan, and worked upon it until it was executed. But this was not done immediately, as the great difficulty was to provide for the necessary ventilation of the battery

and at the same time guard against descending mortar-shells. However, by the middle of October sufficient protection had been given to warrant the mounting of guns, and two 10-inch columbiads, with one banded and rifled 42-pounder, were placed in position. This "three-gun battery," as it was called, was afterward strengthened by a cribwork of pine and palmetto logs on the exterior of the wall, which had been much battered by the naval fire; and it continued to the end to be an effective adjunct to the defense of the channel, although its guns were never brought into action. A photographic view of the exterior showing the cribwork of this battery, the three embrasures faced with palmetto, and the surrounding evidences of shattered masonry, was obtained later, and affords one of the most typical representative pictures of Fort Sumter refitted under fire. (See page 203.) Thus, while the Federals were fortifying the northern end of Morris Island, the Confederates were strengthening Fort Sumter and perfecting the batteries of the inner harbor.<sup>1</sup>

At length, on the 26th day of October, began the second heavy bombardment, lasting without intermission, day and night, but with varying severity, for forty-one days, or until the 6th of December. The cause and object of it, as given by Major-General Gillmore, were as follows: "In consequence of the reports of prisoners and deserters from time to time that the enemy were at work remounting some guns on the south-east (*sic*) face of Sumter," and also with the intention "to cut down that face so as to enable us, with the fire from our guns, to take more completely in reverse the casemates on the channel fronts."

To describe the progress of this bombardment in as much detail as the first would not be a profitable task. The damages were less observable and the aggregate results less important. Yet its duration was more than twice as long as the other,

<sup>1</sup> *Reconnaissance of Long Island*.—This was attempted several times in October, 1863, under orders from General Gillmore, with a view to opening up "a basis of operations for a new attack." In charge of this duty, Colonel W. W. H. Davis, One-Hundred-and-Fourth Pennsylvania, says: "In each instance we were foiled by the watchfulness of the enemy. Pickets were stationed on the shore and armed boats patrolled the water. . . . The enemy was always on the alert."

and it differed widely in character from the former, being at close range for the rifle-guns and easy range for mortars, which were now for the first time employed by the enemy. In fact, these mortars seemed to predominate in the firing. Another prominent difference also was the constancy and vigor of the night-shelling.

But the leading events of the period are well worthy to be reviewed. The heaviest firing occurred in the first week or ten days of the bombardment. On two of those days more than one thousand projectiles per diem were discharged at the fort. The gorge and the sea-face appeared to be the parts aimed at by the rifles, and they soon began to show the effects of the fire. Its destructiveness was increased by the cross-firing of the monitors, two of them being under orders every day to co-operate with the land-batteries. They would take their station off the eastern or sea-face, and while the land-batteries were forced to deliver only a slant fire on the fort, they would throw against it, squarely, heavy rifle as well as smoothbore projectiles. In consequence, the ramparts and arches of the upper casemates were soon cut down, and the débris, falling outside, formed now, for the first time, a practicable slope for assaulting-parties landing in small boats on this sea-face as well as on the gorge; while the ruins of the barracks, accumulating on the inside, gave the garrison in some places an easy ramp for ascending to the crest of the wall. The two angles, however, at the respective extremities of the sea-face, maintained their original height, lessened only by the destruction of the parapet. The crest of the gorge, though not reduced in height, except at one place, was much worn away and sharpened. A remark occurring in the *Diary* of the rear-admiral at this date is highly descriptive: "The heap of rubbish at the gorge looks invincible."

As might be supposed, this period was marked by frequent casualties. Sentinels would be struck down at their posts at night, exposed more particularly on the lookout ladders. Mortar-shells sometimes found their way into the casemates of the three-gun battery before these could be made perfectly secure, and were very fatal in such close quarters. But the loss of life occurring at three o'clock on the morning of October 31st was



of a still more distressing character. One of the detachments, posted at night for the ready mounting of the sea-wall in case of alarm, was ordered to sleep with arms and accoutrements in the lower story of the eastern barracks near to their northern end. Both the upper stories of this building had been badly damaged by this time; but the rubbish accumulating on the second story seemed to be well sustained by the flooring of brick arches resting on heavy iron girders built into the walls for that purpose. So it happened that under this hitherto undisturbed shelter thirteen men, posted in what was thought a comparatively safe place, were sleeping on their arms when a shell brought down the overloaded floor upon them, and instantly killed them. This loss, with its attending circumstances, was deeply felt in the garrison and in the city of Charleston, whence most of the soldiers had come. With one exception they belonged to Company A of the Washington Light Infantry and were attached to the Twenty-fifth South Carolina regiment. The names of the killed will be found in the note below.<sup>1</sup>

A few days after the bombardment set in a change was made in the harbor commands. Brigadier-General Ripley, to whose head-quarters Major Elliott had been reporting, was put in charge of a larger district, and Colonel Rhett, the former commander of Fort Sumter, was once more installed in close though advanced relations to his old post. This arrangement continued for some considerable length of time, Major Elliott reporting the remainder of his term of service to Colonel Rhett, acting as brigadier-general.

<sup>1</sup> Sergeants W. C. Owens and J. A. Stevens; Privates O. J. Burn, S. L. Burrows, F. M. Burrows, S. C. Anderson, James Calder, W. E. Gibson, J. W. Jones, L. S. Lee, and W. L. Patterson, all of Company A, Washington Light Infantry. In addition to these were Private W. Martin of Twelfth Georgia battalion and Mr. Mathewes, overseer of hands.

Later, 21st of November, a similar accident occurred, and is described in the engineer's diary as follows: "At 5.20 A. M. a remnant of the terreplein arch, east centre of gorge, was struck by a Parrott shell, and, falling inwardly into the parade below upon a working-party, buried ten of them in the ruins. I had used every endeavor before dark to pull down the arch with ropes, but could not succeed. Two white men were wounded, two blacks killed, and six wounded by the fall; but three of the wounded are severely hurt; the others are only slightly injured.

Resort was had at this period to a novel measure of offensive operation. Some very fine Whitworth rifles with telescopic sights had been obtained through the blockade, and after a little practice were found to be quite effective from the walls of the fort upon the artillerists of Morris Island. Although the range was fully thirteen hundred yards to Cumming's Point, the sharpshooting with four of these rifles was quite satisfactory and the effects on the enemy's detachments evident. The disparity in weight of metal was prodigious.

But the chief concern of the commander was to be found ready for another assault by night with small boats. This he had every reason to apprehend from the fury of the bombardment in its first period and the darkness of the nights. Besides using a continual vigilance, personally visiting and inspecting the posts and guards every few hours, he caused to be prepared at the fort several devices for obstructing the practicable slopes on the exterior of the gorge and sea-face. These obstructions were of spiked plank, wire entanglements, and chiefly sections of *fraises*, presenting a bristling array of wooden pikes held together by a light scantling frame and supported by feet on the lower side. The placing and recovering of these last obstacles every evening at dusk and every morning before daylight was a task of no little danger and difficulty. They were necessarily placed far enough below the crest not to interfere with the infantry fire behind and above them, and the exposure of the squads charged with this duty was frequently attended with casualties.

From among the detailed men, mechanics, of the Engineer force, Private John H. Houston, Company B, Twenty-fifth South Carolina volunteers, was selected to superintend this work. For a year or more, night after night, he continued to perform this special duty with skill, thoroughness, and distinguished bravery. (For further illustration of his valuable services see the next chapter, note on page 204.) He was promoted the following year to be second lieutenant in the Second regiment of Engineer troops.

The wire entanglements also, placed in sections near the foot of the slope, were taken in every morning to prevent destruction.

In addition to these, a boom of logs and iron chains was maintained about thirty yards off from the fort, to impede the boats in the act of landing. As this had to stand the day as well as the night firing, it was often cut up and required to be repaired. Mountain-howitzers were now first mounted on the crest of the exposed slopes, but were withdrawn in the day-time.

Frequent alarms kept the garrison on the alert and justified every measure of caution or defense. Although there were furnished nightly two or more picket-boats from the Confederate naval force in the harbor to guard the approaches to the fort on the sea-face and on the gorge, the Federal scouts would occasionally pass in between them and row quite around the fort.<sup>1</sup>

It must have been by eluding the water-picket that a daring reconnoissance was made immediately after dark on the evening of the 2d of November. Three scouts in a small boat from Morris Island landed at the south-eastern angle, and when discovered were mistaken for Confederates and hailed by the sentry. As soon as they sprang for their boat the alarm was given and some shots were fired at them, but they escaped in the darkness. The leader was a "Captain Ferris, commanding the boat-infantry." Soon after dark in a small boat with two men he pulled over to the fort and landed with one man. He climbed up the battered wall part of the way, when the boat was discovered and challenged. "The man in it had the good sense to parley with the sentinel a few minutes, which gave the captain and the other man time to get down into the boat before they were fired upon;" one of them was then wounded. (*History of the One-Hundred-and-Fourth Pennsylvania Regiment*, by W. W. H. Davis, ch. xxii. page 290.)

On the night of the 17th, again, there were as many as four alarms caused by small boats reported quite near the fort; and on the night of November 19th-20th, Major Elliott, having become suspicious of attack and made all preparations, was not disappointed. For at 3 A. M. "barges, variously estimated at from four to nine in number, approached within three hundred yards of the fort and opened fire with musketry." The garrison

<sup>1</sup>*Operations, etc.*, Gillmore Correspondence, page 348. This service was attended with great hardship and exposure in gales and wintry weather.

returned the fire, wounding three men in the boats, and disconcerting them from further advance. This was a planned attack by the army-barges, carrying two hundred and fifty men, but it seems to have had little determination in it. As before, on the night of the 8th of September, the batteries of Sullivan's Island and Fort Johnson on James Island came to the assistance of Sumter. The ricochet practice from Sullivan's Island was reported "very handsome" by Major Elliott. It appears that this was a reconnoissance in force commanded by Major Conyngham of the Fifty-second Pennsylvania regiment. "The instructions were to make such demonstration against Fort Sumter as to induce the garrison to use their musketry-fire on the boats, and thus ascertain its strength. An assault was not to be made upon the fort unless it was evident that it could be easily taken. . . . The garrison appeared to have been on the watch. The boats were fired on from Fort Sumter, James and Sullivan's Islands, and by a steamer, probably a ram, that lay behind the angle of the fort toward Charleston." —(W. W. H. Davis.)

The calcium light has been mentioned as used by General Gillmore with success in his siege of Battery Wagner. It was now put to use again, and very often, from Cumming's Point, lighting up the water between Morris Island and Fort Sumter well enough to discover small boats, but failing to illuminate the fort as brightly as it had done the battery. Toward the middle of this second bombardment, on the night of the 11th of November, the light was displayed at Battery Gregg for the first time. It was not so bright as the full moon, but one could read by it at the fort the large capitals of a newspaper. It was thought at first that the enemy's purpose might be to discover the parties working at repairs or placing obstructions on the slopes, or possibly to detect the passage of the transport-boats to and from the fort. But observation decided that the use of the calcium light was rather for defensive purposes, to reveal the approach of hostile boats from the Confederate side. The importance of the light in warfare cannot be too highly estimated. At Fort Sumter the defense might have been very greatly simplified by its use; but the shining mark it would have afforded

the enemy was enough, at this period of short-range firing, to condemn it.

This calcium light was a great annoyance to the sentinels, for it seemed to fascinate their gaze, diverting them too much from the proper objects of their watch; and, in fact, it blinded them no little by interposing its plane of illumination with dazzling effect between their eyes and the dark waters of the harbor around them. The appearance of the light would sometimes be striking and beautiful, as from a focus of the intensest brilliancy the rays would appear to dart forth and flash upon an expanse of inky blackness; then, touching or tipping the crest of the gorge, they would stream across the empty darkness of the interior, to be caught and reflected by the jagged pinnacles of the northern wall, standing out for the time in bold relief against the midnight sky above and the gloomy crater of the fort below.

In fact, the view of the fort by night was at all times most impressive in its strange, silent grandeur. To a beholder looking down from the rim of the ruin, all within seems alike dark and gloomy, save when a chance shower of sparks, blown out from a smouldering fire left in the parade, lights up for a moment some great, rugged blocks of brickwork and the pool of stagnant water into which they were tumbled from the battered walls some days before. Lanterns here and there glance across the spacious enclosure as, borne by unseen hands, they light the way—some for long files of men toiling with heavy timbers or bags of sand over the roughest footing and up steep, crumbling, dangerous slopes; some to direct the heaping of material over damaged hiding-places, repaired for perhaps the fiftieth time since the firing began, or to secure a new and better shelter for the garrison; others, flashing through chance crevices in the ruined casemates, tell of secret galleries of communication burrowing deep and mining their way slowly under hills of rubbish to give unity to the work and confidence to its defenders.

Halfway up the sloping ruins of the fort, which resemble most the interior of an ancient amphitheatre, the guards are posted in groups, dimly seen wrapped in blankets, sitting around a little fire allowed to warm, but to give no light. Higher yet

are the sentinels peering into the night over the remains of the old fort's ramparts, while last, though not least, is the solitary "lookout," exposed full length to the dangers of the firing at the top of some ladder put up at the most critical breach.

Even in the midst of this heavy bombardment a new system of interior defense was instituted and carried out. It was with the purpose of contesting every foot of the parade and casemates against an enemy so bold or successful as to drive the garrison from the walls. Every quarter from which a view of the interior could be had was now carefully loopholed for infantry fire, and at a favorable position near the north-western angle a 12-pounder howitzer protruded every night from under a low-browed arch, in readiness to sweep the parade with grape and canister. It was part of the plan also that, should the necessity ever arise, the harbor-batteries would, by signal given from Fort Sumter, open upon the assailants within the walls, exploding or dropping shells among them, until they were forced to leave. This "best-laid scheme," however, was never realized; nor was it much talked about, for fear of begetting distrust in the far more advantageous plan of battle from the walls. It was only reserved for a last resort.

Among the officers of the First regiment of South Carolina Artillery, who continued to perform with their companies occasional duty at the fort, no one was more efficient and acceptable to the commander than Captain Francis Huger Harleston of Company D. In a despatch of November 20th, Major Elliott writes: "I respectfully request that, if practicable, Captain Harleston be retained here until the dark nights have entirely passed by. His removal just at this time will be a great misfortune to me, as I am greatly dependent upon his watchfulness and ability." It was only three nights after this testimonial was given that Captain Harleston's valuable life was sacrificed willingly and heroically to the cause he was defending. Quartered with his company in the armed casemates of the north-eastern angle, he had been put by the commander in additional charge of the adjacent sea-face, battered down to half its original height, and presenting, in places, even a practicable slope for assaulting forces of the enemy. The night of the 23d-24th of Novem-

ber was one of those occasions when vigilance was especially needed. The enemy's fire, usually limited at night to shelling with mortars and 30-pounder rifles, had been heavier than the average rate, and toward morning the tide and wind together began to rise and beat with violence on the crumbling débris of the eastern slope. One of his sentinels reported to Captain Harleston (4.30 A. M.) that the waves were threatening to wash away some of the sections of fraises placed for obstruction half-way down to the water's edge. Instantly responding to the report, the active young officer climbed over the crest and began to pass along the line of obstructions, inspecting as he went from one end to the other, accompanied by J. H. Houston of the Engineer department. While so engaged he was mortally wounded by a 30-pounder rifle shell passing between Houston and himself, striking him, apparently before bursting, in both thighs and one arm at the elbow. Being lifted and borne in great pain to the hospital, he lingered, and died six hours after he fell at the post of duty,<sup>1</sup>

For instances of gallantry in replacing the flag under fire this second bombardment more than equalled—it surpassed—the first. It seemed almost as if the spirit of 1776, so bravely illustrated by Sergeant Jasper in the battle of Fort Moultrie with the British fleet, had been for nearly a century preserved “in the air” of Charleston harbor and cherished in the bosoms of all who defended it.

The first occasion of this kind is thus recorded in Major Elliott's despatch of October 29th, being the third day of the bombardment: “The flagstaff was shot away this morning. Private William A. Dotterer and Privates James Silcox and George H. Force, and Sergeant Robert A. McLeod of the

<sup>1</sup> He was a graduate with first honors of the South Carolina Military Academy, class of 1860. Distinguished there, he made good the promise of cadetship by active and efficient service in Charleston harbor. Prominent in every action from the beginning of the war, he won the praise of all who served with him, for he combined in remarkable degree the best qualities of a spirited, sagacious soldier with those of a true and gentle friend. This accomplished officer fell before completing his twenty-fourth year. His State lost him from among the flower of her youth, and the Confederacy had no better young soldier in all her armies.



Captain F. H. HARLESTON, First Regiment S. C. Artillery,  
Killed at Fort Sumter, November 24th, 1863.  
From a Photograph.





Washington Light Infantry, assisted by Captain James M. Carson, officer of the day, gallantly replaced the flagstaff under a very heavy fire from Gregg."

The second and third occasions, recorded by both the major commanding Fort Sumter and the rear-admiral whose monitors were pounding the fort, belong to the same day, the 31st of October. The flag was at this time flown at the south-west angle from a staff planted in the massive covering of sand heaped over the spiral stairway. This covering of a vital part of the work was, throughout its defense, maintained with peculiar pride at its original level, the highest point in the fort—viz. forty feet above the water. The rear-admiral says: "The Patapsco and Lehigh firing very well, scarcely missing. The flag-pole (at south-west angle) shot away twice, once by the Lehigh. A man got out on the wall and put it up."<sup>1</sup> The mention at Fort Sumter was by the commander in the following terms: "The flagstaff was shot away twice, and replaced by Sergeant Graham, Corporal Hitt, and Private R. Swain, all of Company F, Twelfth Georgia battalion. The flagstaff was so cut up that it was necessary to raise the battle-flag of the Twelfth Georgia battalion in the place of the flag."

The fourth instance was on the 6th of November, and is thus chronicled in the post-book of Fort Sumter: "The flagstaff was shot down to-day, and was replaced by Sergeant W. D. Currie, Company D, and Corporal S. Montgomery, Company C, Twenty-fifth South Carolina volunteers." It appears that this was a new flag and staff (raised only the day before) on the south-eastern angle, nearest to Morris Island.

The fifth was entered under date of the 12th of November, and mentioned in these terms: "The flag was replaced by Sergeant G. H. Mayo, Company B., and Private Robert Antry, Company C, Twenty-eighth Georgia volunteers."

The sixth and last occasion during this bombardment was more memorable than the rest, because of the difficulties as well as dangers encountered and overcome. The flag had now been kept flying at the south-eastern angle for some time, where its staff was partly protected by a parapet of sandbags arranged to

<sup>1</sup> *Memoir of Dahlgren*, page 421.

give some shelter to the sentinel posted there by night and day. On the morning of the 27th of November, "Private James Tupper, Jr., shot-marker Company D, Twenty-seventh South Carolina volunteers (Charleston battalion), seeing that the flag had been shot down, walked along the whole extent of the gorge-wall on the parapet" (there was no parapet left there, only a thin, ragged crest) "and endeavored to raise it: finding that the staff was too short, he procured an additional piece of spar, and with the assistance of C. B. Foster of same command, and Corporals W. C. Buckheister and A. J. Bluett, Company B, same corps, succeeded in splicing and planting the staff under a very heavy fire directed at them. One shot cut the flag from their hands. It was a most distinguished display of gallantry."<sup>1</sup> The time occupied must have been fully fifteen minutes. The men were more than once hid from view by the smoke of bursting shells and the sand thrown in clouds about them. Their escape from all hurt was very remarkable. At the conclusion of their daring feat two of the party mounted the little parapet of sand-bags and waved their caps at the enemy in triumph. The bravery of Tupper and his comrades was made the subject of a complimentary order by General Beauregard; they were all mentioned by name and their example commended to the whole department.

As December came on the bombardment began to wane. On the 6th, for the first time in forty-one days, no shot was fired against the fort, and so its second great ordeal was passed.

The results were briefly these: The sea-face or right flank of the work had lost the greater part of its upper casemates, the débris having formed large accumulations, with occasional practicable slopes, both within and without. From its original form, a perpendicular wall forty feet high, it was changed to an irregular mass of rubbish averaging twenty feet in height above tide, and showing a rugged crest of about six feet in width on the top. But the lower casemates, all filled with sand, were still forming the bulk of this barrier. The angles of the fort at either extremity of the sea-face still retained the level of the old terreplein of the ramparts. As the northern wall had been heavily battered in

<sup>1</sup> Post-book, Major Elliott's despatch.

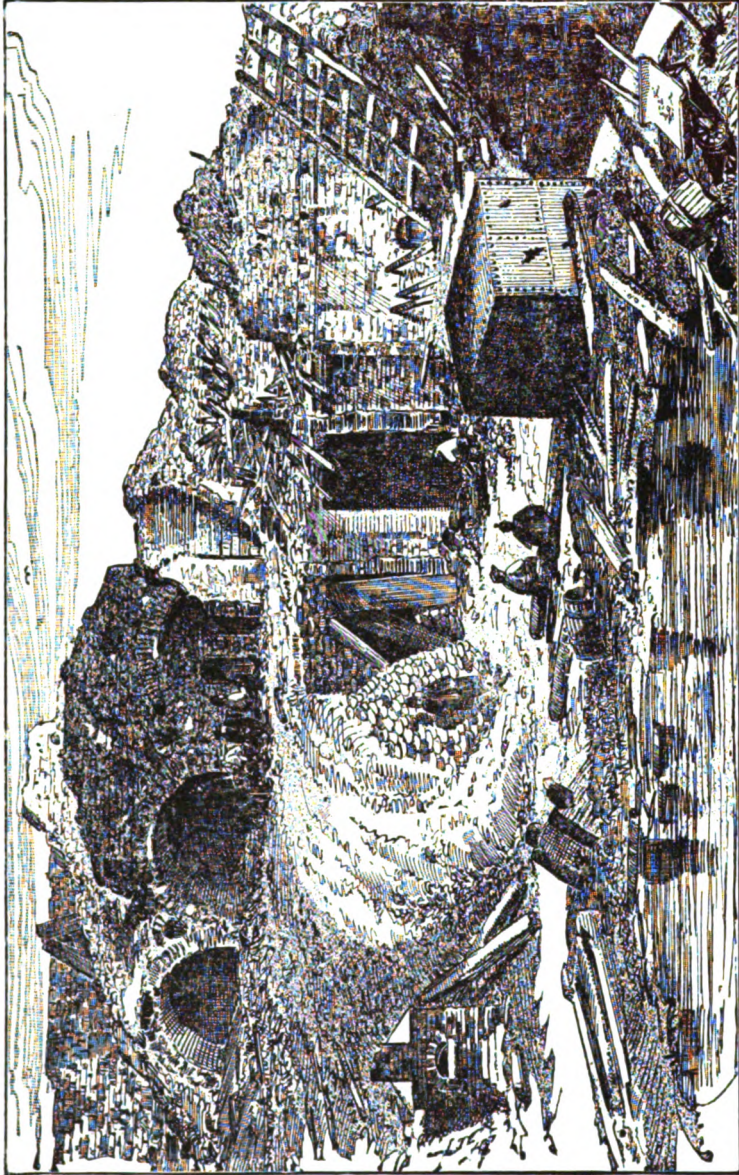

**FORT SUMTER: Interior of the Eastern Angle of the Sea-face, December, 1863.**  
(From a drawing by Lieutenant John R. Key.)

reverse, it now presented the appearance of a range of rocky mountains, with an average height of twenty-five feet above the water, but no slope of débris on the exterior was protective of the lower casemates. The gorge had been changed in only one particular: as, on the northern wall, the focus or line of converging fire was well marked by a large breach made by missiles coming in reverse, so there was a large semicircular gap in the crest of the gorge about midway between its centre and its eastern extremity, caused by the same converging fire on the mass of the fort.

On the other hand, the Confederates had preserved and improved their quarters and perfected a system of interior defense. The great end striven for by the enemy—the destroying of the “three-gun battery” on the channel front—had been defeated: the guns were all in good condition and the casemates practically serviceable.

As a general thing, the soldiers of the garrison were spared fatigue-duty, the better to fit them for vigilance and activity at night. The labor and exposure of repairing damages, filling in and over weak places, setting and recovering the obstructions, making changes and improvements and accommodation, fell properly to the working-force, consisting at this time of one hundred negroes and a gang of ten white mechanics, organized under directions of the engineer in charge. The negroes were relieved every fortnight, were securely sheltered and rested in the day-time; but as night came on they would be put to work and continued at it until daylight. Necessarily more exposed than the garrison, though never unduly so, they suffered casualties in proportion when at work, but never in quarters, as the garrison more frequently did.

Captain J. T. Champneys served faithfully and efficiently as engineer in charge from September 3d to November 6th, being the twelfth day of the bombardment just concluded. On this night of the 6th–7th of November he was relieved by the return of Captain John Johnson to his old post. So important had now become the regular furnishing of the fort with sufficient materials for defense that great care had been taken by Lieutenant-Colonel Harris, chief engineer of the department, to secure for Fort Sumter the requisite supplies of sand, gabions, timber,

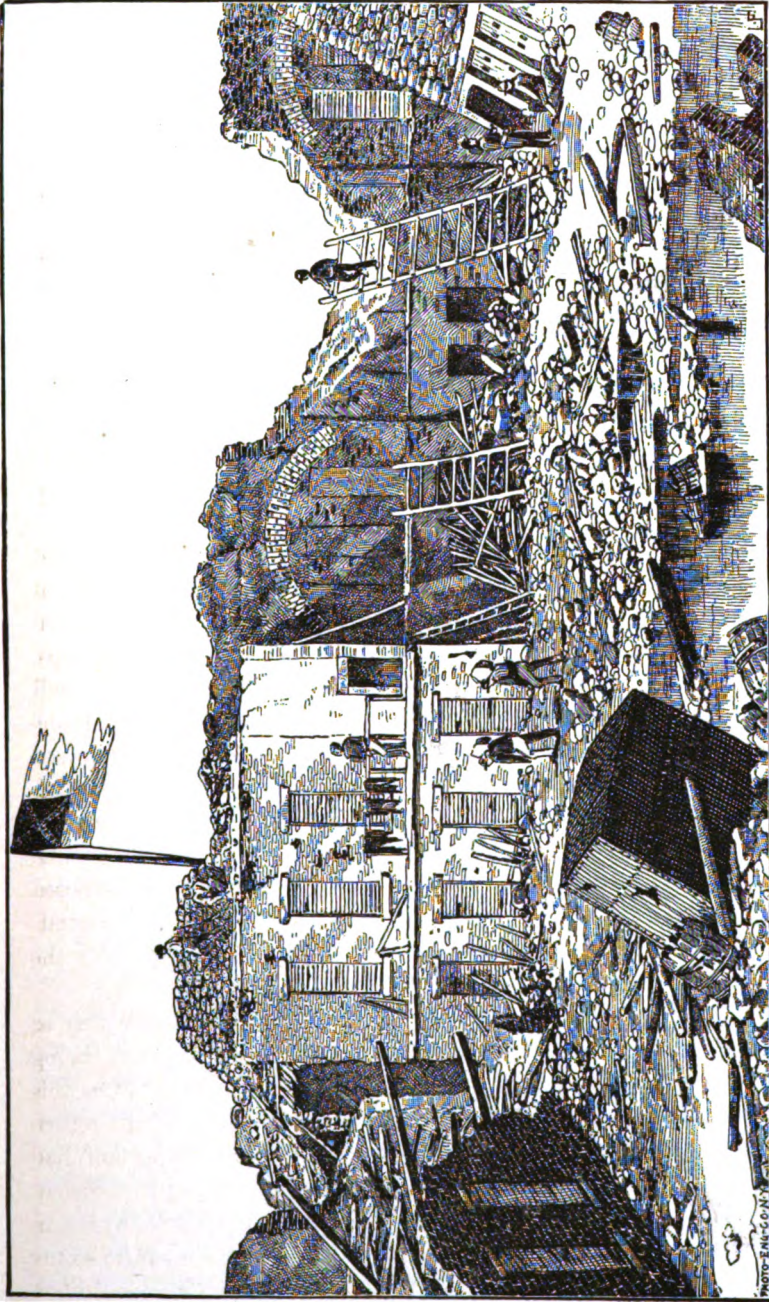

**FORT SUMTER : Interior of the Eastern Angle of the Gorge, December, 1863.**  
(From a drawing by Lieutenant John R. Key.)

irons, implements, and tools ; the preparation and transportation of these every night, except in stormy weather, was entrusted to a special officer in Charleston, Lieutenant W. Gourdin Young of the Engineers, who long continued to forward the work with skill and diligence.

The services of Mr. (afterward Lieutenant) F. M. Hall as assistant engineer at the fort were also at this period and for many months longer very valuable.

It was at this stage of the defense of the fort that the absolute necessity of regular nightly communication by boats with the city became apparent. Despatches, reliefs, provisions, supplies of material, demanded a regular service of transportation. The quartermaster department, under Major M. A. Pringle, was often in great straits for boats, small and large, and sometimes apparently for captains willing to land at the fort under any fire at all. But there were some who distinguished themselves by a faithful performance of these duties all through the various bombardments of the fort. Prominent in devoted and long-continued service was Lieutenant Thomas L. Swinton (of the quartermaster department), put in charge of the mail-boat more particularly ; and among the commanders of steamboats was Captain W. T. McNelty of the *Etiwan*. Frequently the shelling would be so severe as to require the steamboats to lie off three hundred yards from the fort and send supplies in small boats to the wharf. One of the boats during the first bombardment was blown up by a shell exploding the boiler as she was discharging at the wharf, and barges were frequently injured in the same service.

In reporting the aggregate of shots fired at Fort Sumter during these forty-one days and nights, resort must be had to the counting and registering of them at the fort itself, as no record of them has been found among the Union army authorities. The comparison of the two estimates in the case of the first bombardment showed the Confederate to be slightly greater than the Federal count. In the case of the second grand bombardment the total shot and shell fired by rifles and mortars was 18,677.<sup>1</sup> (For particulars, see Appendix A, Calendar, etc.)

<sup>1</sup> The *naval* fire included in this total was not less than 1000, so far as reported, and was delivered by the monitors *Lehigh* and *Patapsco* with rifles and smoothbores. (Ex. Doc., *Armored Vessels*, page 280.)

## SECOND GREAT BOMBARDMENT OF FORT SUMTER. 185

The casualties for the same time were 30 killed and 70 wounded; 13 of the former were caused by the falling of a floor in the eastern barracks, as previously described. Among the slain, besides Captain Harleston, was an estimable young officer, Lieutenant A. P. Brown, Company A, Twelfth Georgia battalion, who was killed by the naval fire on the second day.

The large number of night-alarms was a feature of this period, and served to train the garrison to the utmost vigilance and promptness. So many small boats as were seen from night to night could only have been under orders to reconnoitre the fort with a view of attempting a second assault. As always happened, the garrison was found to be on the alert and not to be surprised in this manner. The discovery may have deterred from the attempt.



## CHAPTER X.

### EXPLOSION OF MAGAZINE AND FIRE IN FORT SUMTER.

December 6, 1863—May 4, 1864.

VIEWS OF THE FORT TAKEN AFTER THE SECOND GREAT BOMBARDMENT—A BRIEF SEASON OF REST—THE SMALL-ARMS MAGAZINE BLOWN UP BY ACCIDENT, DECEMBER 11TH—DEATH OF CAPTAIN FROST, WITH TEN OTHERS, AND MANY WOUNDED—HEAVY SHELLING (SECOND MINOR BOMBARDMENT)—WESTERN CASEMATES CATCH FIRE FROM EXPLOSION—EXTENT AND SEVERITY OF INJURIES—CRITICAL CONDITION OF THE FORT FROM SCARCITY OF SHELTER—REBUILDING OF TOWER-STAIRS—CONSTRUCTION OF A LONG GALLERY BY MINING THE RUINS OF THE NORTHERN CASEMATES—A CHRISTMAS DINNER IN THE "THREE-GUN BATTERY"—THE THIRD MINOR BOMBARDMENT—GALLANT REPLACING OF THE FLAGSTAFF—OPERATIONS ON JOHN'S ISLAND—SINKING OF HOUSATONIC BY TORPEDO-BOAT—WASHINGTON'S BIRTHDAY CELEBRATED WITH A BANQUET—ALARM BY BELL-RINGING ARRANGED IN THE QUARTERS—FOURTH MINOR BOMBARDMENT—GUNS MOUNTED IN THE WESTERN CASEMATES—FIFTH MINOR BOMBARDMENT—GENERAL BEAUREGARD GOES TO DEFEND PETERSBURG, VA.—MAJOR-GENERAL SAMUEL JONES SUCCEEDS TO THE COMMAND OF THE DEPARTMENT—LIEUTENANT-COLONEL ELLIOTT PROMOTED AND TRANSFERRED, AFTER EIGHT MONTHS' SERVICE IN FORT SUMTER, TO THE ARMY IN VIRGINIA.

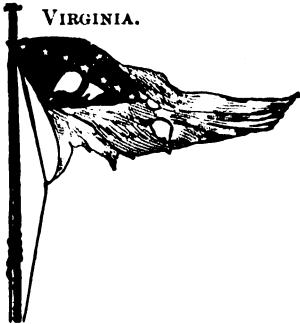

FORT SUMTER'S FLAG, JANUARY 29, 1864.

(From a sketch by the author.)

It has been mentioned that the second great bombardment came to an end December 5, 1863, after a duration of forty-one days and nights.<sup>1</sup> The fort enjoyed, through the greater part of December and January, a quiet that was highly favorable to repairs and improvements, while it was visited at the same time with a calamity more destructive than the enemy's fire could have been.

<sup>1</sup> On the next day the monitor *Weehawken* foundered at her anchorage off Morris Island. (For particulars see Appendix of this chapter.)

Previously to this, however, on the night of the 7th of December, Lieutenant John R. Key of the Engineers, and Mr. Chapman, artist on duty in the chief engineer's office at Richmond, arrived under orders to execute sketches and take views of the historic ruin. The period was well chosen, for, besides being at the close of a severe bombardment, it marked also what was the most picturesque stage of the fort's ever-changing appearance. The bold and striking outlines of the northern wall had only been produced by the recent firing; and they were soon to be lost in the changes which attended the gradual conversion of Fort Sumter from a brick- to an earth-work. In the same way, the scene of confusion all over the parade was to give way before long to more orderly arrangements.

The view presented is one of two drawn with great accuracy by Lieutenant Key, copies of which were photographed, mounted, and sent with autograph presentation by General Beauregard to both Lieutenant-Colonel Elliott, the commander, and Captain Johnson, the engineer in charge—a gift and compliment, as might be supposed, very highly appreciated by them.

The observer is looking eastward, with his back turned to the city of Charleston. The sea-line of the horizon is at a high level before him; the shores of the entrance to the harbor and the expanse of water within and beyond the bar are spread beneath his eye. The blockading fleet, and more particularly the iron-clad squadron, are visible in the distance. In the foreground is Fort Sumter, its flag flying from the south-eastern angle, nearest to Morris Island, its gorge extending from that point to the south-western angle, where the sentinel stands at the passage down the spiral stairway. The eastern or sea-face, beginning at the flagstaff, runs toward Sullivan's Island as far as the square door-head seen near the ruined arches in that direction. Just below, in the parade, is seen one of the hot-shot furnaces, almost covered by the foot of the large mound which protects the "three-gun battery" from the reverse fire of the Federals. About the centre of the next or north-eastern face will be noticed two arches of the lower casemates which adjoin the battery, and are loopholed for infantry-fire upon the interior and the crest of the gorge. The northern wall is marked by peaked

and jagged masses of remaining masonry, and extends to the vicinity of the two lower arches, covered with gabion-work and opening toward the parade. Under the observer the casemates of the city face are situated; here are located soldiers' quarters, the hospital, sally-port, head-quarters, and the telegraph office. Midway on the gorge, outside the fort, is seen the original stone wharf, while within appears the rounded covering of the "centre bombproof," as it was called. The ladders observed at various points are necessary to the manning of the walls in case of assault by night. The wrecks of platforms and gun-carriages, the dismantled guns half buried in the ruin,—the picture of destruction, in a word, is not in the least exaggerated.

Since the bombardment, matters at the fort had begun to settle down into something like quiet, and even comfort. The soldiers of the garrison would sun themselves with great enjoyment on the cold days, and the working-force was kept steadily engaged at something more like progressive improvement than their late nightly employ of filling the furrows ploughed by the rifle-shots on the exterior slopes or the more regular craters made by the mortar-shells dropping all over the fort. The carpenters were busy in the quarters, making them more comfortable for the winter, and everything betokened a sense of relief from troubles past and a brave spirit of endurance for the future. At this juncture a disaster of the most serious and distressing nature befel the post.

• Inconsiderable as were the necessities of the fort, there had been for some time past three magazines stored and ready for use. It was convenient, and it seemed wise, to separate the ammunition as much as was consistent with safety. The arrangement was as follows: a service magazine adjacent to the "three-gun battery," a reserve magazine in the recesses of the "centre bombproof," and a third, for the small-arms and howitzer ammunition, in the inner chamber of the original magazine of the south-western angle. This was the lower pair of chambers, those belonging to the upper casemates having been long since abandoned and partially filled with sand. The small-arms magazine, then, as it was called to distinguish it from the others,

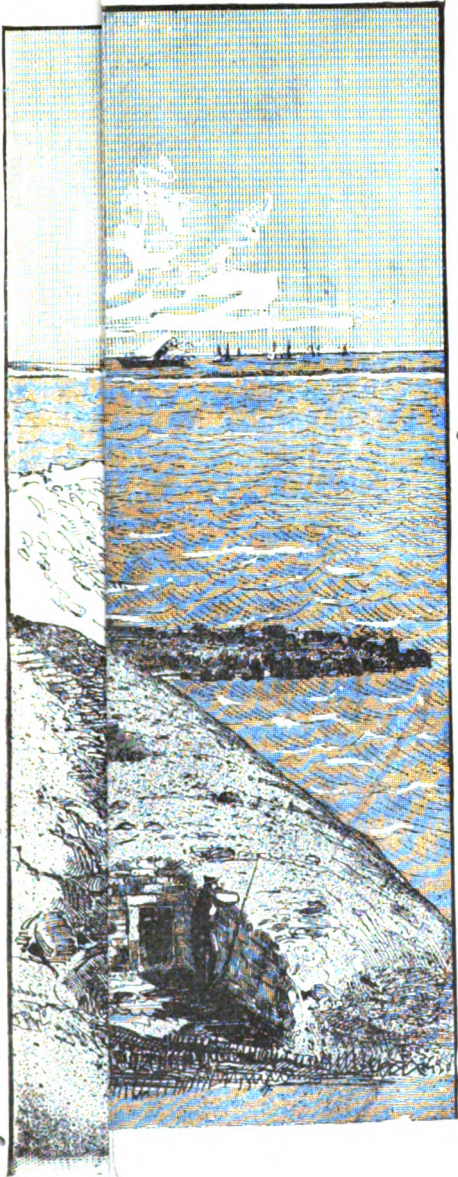



lay secure behind the massive protection of brick and stone, together with the fallen débris afforded by the exterior of the gorge in that vicinity. It was next to the spiral stair-tower in the south-western angle, and adjoining the western or city face of the fort. But both chambers were not in use for purposes of a magazine: the limited accommodations of the post furnished no secure place for the commissary stores, and they were accordingly kept in the outer chamber of this magazine. It was known to be hazardous so to divide the use of the two chambers, but there seemed to be a necessity for it in the straitened circumstances of the fort. The contents of the inner chamber consisted of an incongruous assortment of rifle-cartridges, fixed ammunition for howitzers, hand-grenades, fire-bottles, signal-rockets, sensitive tubes for priming, shells and torpedoes, etc. etc. Perhaps three hundred pounds of powder would have made up the explosive total.

This magazine was blown up at half-past nine o'clock on the morning of the 11th of December, with many casualties and much damage to the fort. The enemy had not fired a shot for several days, and the sentinel at the look-out reported no gun fired at the fort that morning before the accident. The safety of this particular locality from all kinds of shelling had never for a moment been questioned. All who could have told the cause perished in the explosion. There were 11 killed and 41 wounded, only 9 of the latter being dangerously so.

Among the killed, having fallen at his post in the commissary store, was Captain Edward D. Frost, A. Q. M., serving as post-commissary. This officer had but recently reported for duty, but was well known for business capacity and esteemed for his fine traits of character. Unfortunately, the commissary store and the passages communicating with it were at the hour of explosion crowded with soldiers drawing rations, while the narrow limits of the chambers and galleries adjacent, together with the impossibility of the powder-blast finding much expansion upward, will account for the large number of sufferers.

But the results extended beyond casualties. Outwardly, there was little effect visible to the enemy: the noise was too dull to have reached them, and they could have been made aware of

the explosion only by noticing at the instant the upheaval and subsidence of the *débris* above the magazine. This displacement left no change in the appearance of the gorge-slope, so far as they could see; but high up, near the crest, a pit eighteen feet square and about ten feet deep had been made, as the whole superincumbent mass fell into the open space below. Yet by the smoke the accident was discovered, and the batteries opened with guns and mortars on the fort within ten minutes after the occurrence. Inside, the effects were immediate and violent, followed by others more serious and destructive. The noise of the explosion was not loud, but accompanied by the heavy, crashing sound of falling masses. The blast from the magazine rushed into the adjoining commissary store, where the morning issues were going on, and thence into the passage communicating on the one hand with the circular stair and the casemates of the western front, and on the other with the gallery leading out into the parade. In its course the occupants of these thoroughfares were instantly killed; and its violence, with concussion and scorching, was transmitted even up the stairway and into the nearest casemates of the second tier, where several companies of the garrison were quartered.

At this early stage the aspect of affairs was most alarming. All the localities just mentioned required constant lighting, and were now plunged in total darkness. At the lower casemate on the city front,<sup>1</sup> occupied by Lieutenant-Colonel Elliott and Captain Johnson, it could not be immediately divined what had happened, nor could it for some minutes be determined. The principal noise was that made by heavy bodies falling to the ground, and although the smoke of powder came with it the explosion was attributed not at first to the magazine, but to the chest of hand-grenades and combustibles kept in readiness to repel assault at the top of the spiral stairway. These, it was thought, might have been reached by a chance shell from the batteries of Morris Island. And even when, upon pushing through the throng of terrified and wounded men making for

<sup>1</sup> This was next to the postern and near to the scene of the accident. A few months later the head-quarters casemate was one about midway on the city front, and so remained until the end.

the open air, it was seen that a furious fire was already raging in the commissary storeroom, the true cause was not conjectured, for it was feared that this fire would blow up the magazine at any moment. Those who could have told the true story were lying dead in the chambers and passages, and nothing trustworthy could be obtained from the lips of the wounded men. It was only as the flames increased and the explosion was placed beyond a doubt as already past, that the real nature of the occurrence could be understood.

But the relief of mind, if relief it was, could not last long. Already the flames, fed by the combustibles of both the ordnance and commissary stores, were defying control. Hot air and dense smoke were filling all the passages, forcing out the men in the lower and cutting off those in the upper casemates. In this extremity numbers of the latter were passed down by ladders, outside of the city front, through an opening recently made for a *machicoulis* gallery in that vicinity. A determined effort made by Captain Alfred S. Gaillard and some of his men of the First South Carolina Artillery to barricade the passage-way leading into the western casemates, by the free use of wet sand-bags piled in haste to arrest the flames, was, after a struggle for breath, defeated. Nothing remained but to reduce the draft by obstructing all the available openings, the embrasures, the doorway of the stair-tower on the ramparts, the postern near the south-western angle, and the gallery leading from the magazine into the parade. This was little, but it was all that could be done, and the fire was left to expend itself.

It has been said above that the enemy opened on the fort soon after the explosion.<sup>1</sup> Some casualties occurred from this firing, the commander being slightly, and Percival Elliott, acting adjutant of the post, being severely, wounded. During the firing, which lasted for some hours, there was required to be constant exposure in crossing the parade and communicating around the

<sup>1</sup> It is difficult to avoid making the comparison here between the war-spirit exhibited in this and the generosity in that action of General Beauregard in April, 1861, when, seeing Major Anderson's barracks set on fire and his magazines endangered, he offered to send fire-engines to the fort; which offer was declined. (*Military Operations*, vol. i. p. 46.)



outside of the fort between the burning casemates and the "three-gun battery," where now the commander established his headquarters. Among those who rendered valuable service at this juncture and obtained honorable mention in the official report of the day were Captain M. H. Sellers and Lieutenant L. A. Harper of the Twenty-fifth South Carolina volunteers, Mr. W. R. Cathcart, telegraph operator,<sup>1</sup> and a boat's crew with water-buckets sent to the fort under fire from the Confederate ram lying off Fort Johnson. Besides these, a detachment of Georgians worked bravely in the parade, and Lieutenant Logan of the Twenty-fifth South Carolina volunteers distinguished himself. This shelling continued for several hours.

By noon the flames had consumed everything combustible in the upper casemates adjoining the south-western angle, and had begun to destroy the upper flight of wooden steps in the same locality, and finally the valuable bombproof timbers which covered and secured the stair-tower itself. Their progress was slower in the casemates of the first tier, and not until nightfall was the woodwork in them consumed, the fire stopping at the howitzer platform in the casemate of the new sally-port. In the other direction, from the magazine inwardly to the parade, the principal thoroughfare gallery of timber construction was destroyed until about midway of its length, where the caving-in of sand from above arrested the flames.

Access to the upper casemates was obtained by copious watering in time to provision and reinforce the weary garrison that night. No communication with the wharf could be had through

<sup>1</sup> General Beauregard, in department general orders, commended Mr. Cathcart for "remarkable courage and energy" exhibited on this occasion. Driven by the smoke and flames to abandon his office, this young operator acted with great coolness in disengaging all his wires and moving his instrument in safety to a more distant point; but from that also he was driven after having established himself for a short time. Finally, a place of safety was found, and the submarine communication was restored in two days by the use of additional cable. Mr. Cathcart served long at Fort Sumter—from the opening of the first bombardment under Colonel Rhett to the close of Lieutenant-Colonel Elliott's command, upward of ten months. The obligation of the other branches of military service to both the telegraph operators and the signal corps was constant; and it gave general satisfaction to see the complimentary notice taken of the operator at Fort Sumter.

the lower casemates or the sally-port ; the gates of the latter were burnt away, and the bricks within as hot as though in an oven. It was found necessary to ascend by ladder from the wharf to the opening in the wall already mentioned, through this into the yet smoking casemates of the upper tier, and out of these, by ladder again, up to within three feet of the crown of the arch ; thence finally down fully thirty feet by the rough footing of the débris slope into the parade. Fresh water was supplied by hose passed through an embrasure of the east battery from the water-boat outside. To such straits was the fort suddenly reduced. (For particulars see the commander's report in Appendix of this chapter.)

The lower casemates continued at a high heat until gradually cooled by water during the next two days ; while the commissary store, where the fire originated, was only brought to view after two more days spent in removing the sand caved and fallen to a depth of ten feet in the stair-tower, and in quantities sufficient to fill up the passages. Entrance into the store-room itself was not effected until the tenth day spent in cooling its red-hot walls. The effect of the fire on the masonry here, and elsewhere in less degree, was exceedingly injurious. The arch of the inner chamber or magazine proper had fallen in, entirely filling the space with débris brought down with it from the slope of the gorge. The arch of the commissary room was hanging in the most precarious condition, the cracking of the bricks being audible during the process of cooling. The bricks in the stair-tower from bottom to top were burnt and friable to the depth of an inch and a half. So were the bricks in all the casemates through which the fire had passed. In the second tier the scarp-wall had started away from the piers, in one place a full inch. The pier arches of the lower tier were all cracked at the crown and haunches.

If the particulars of this combined explosion and fire may seem to have been related in too great detail, the reason is that the extent and severity of the fort's injuries have never before been made public ; and, in fact, they were not adequately appreciated by all who knew them at the time. It was not alone the damaged masonry or the desolated quarters, with their urgent

call for immediate attention to the refitting of them and the restoring of all communications, that gave alarm at this juncture ; it was more especially the crowded, uncomfortable, and unhealthy life at the fort which followed upon the disaster, and threatened the abandonment of the post. So much was this the case, that if the enemy had chosen to maintain for one week the heavy fire opened for a few hours on the morning of the explosion the evacuation of the fort might have been necessarily brought about. If the first crisis in Fort Sumter's history had been at the close of the August bombardment, when General Beauregard decided, against the opinion of some, to approve his chief engineer's advice and hold the ruins with infantry to the last extremity, the second crisis was surely this of the 11th of December following. Through default of such harassing fire as the Federals, combining their land and naval artillery, might have kept up for a week or more at this time, the defense of Fort Sumter was successfully prolonged.

A few nights after the catastrophe the fort was visited for the purpose of inspection, and at the request of the engineer in charge, by General Beauregard, accompanied by Colonel Rhett and Lieutenant-Colonel Harris, chief engineer. By their orders the most vigorous measures were immediately taken to restore the burnt quarters and communications of the interior. The furnishing of materials for construction, the transportation, the supply of labor, all received new impulse from this date, and the difficulties seemed only to have stimulated to new and stronger resolves. A magazine was again prepared in the place of the exploded one, by dividing the commissary room, where the fire originated, into two halves of a triangular section, the upper filled in over heavy logs slanted diagonally from top to bottom of the room ; the lower half secured in this way to accommodate the ordnance supplies needed in that precinct of the fort. The brickwork overhead in this chamber was so cracked and damaged as to make the transformation a work of extreme peril until the injured arch was relieved by the sand-filling over the logs.

Stout planks and heavy timber took the place of sandbags, hitherto used in the lower casemates to retain the slopes of the

protecting counterfort. The pier-arches of the same locality were all strengthened with timber frames and centring. The upper casemates of the burnt district were narrowed to receive a framed chamber, eight feet square in section and extending through four or five of them, with sand filled above and around the timbers. These changes in the upper and lower casemates afforded quarters altogether superior to those in use before the accident.<sup>1</sup>

A task of labor and patience was the clearing out and refitting of the stair-tower in the south-western angle, filled for one-third of its total height of thirty-four feet with rubbish, broken stone steps, charred timbers, and sand. Three flights of stairs, capped with the heaviest of timber roofing and covered with six feet of sand, put this most important thoroughfare once more into good condition. From the same tower there had to be entirely rebuilt galleries of communication with the new bombproof quarters of the second tier and with the parade of the fort in the interior of the south-western angle. This latter thoroughfare gallery required to be mined through the sand-filling of two rooms to its opening into the parade, close under cover of the "indestructible" gorge. This work was greatly hindered by the caving and sliding of the sand.

But the undertaking that called for most perseverance and arduous labor was the putting into some order, and even turning to useful purpose, the ruins of the northern and north-eastern faces. The illustrations have shown how utterly demolished these parts were outwardly to the casual observer, but no idea could be conveyed of their inward destruction. With the ex-

<sup>1</sup> It was in this region of the fort that one of the most picturesque effects was produced by the combination of ruin and repair. About midway on the western face one of the upper casemates lay partly open to the reverse fire of the iron-clad ships, and was not used for quarters. But next to it, and communicating with it over the top of a barrier of sandbags, was another casemate where a detachment of the garrison found very good shelter, though but little comfort. This latter became known as the "Robbers' Cave." Everything within and without was of the wildest form and composition. To stand by night where one could spy through the outer casemate, close under its battered arch, over the barrier and down into the dark recesses of the inner chamber, where a flickering fire alone lighted up the soldiers asleep or on guard, was to be living among the mountains of romance.

ception of those used for the "three-gun battery," all the casemates, upper and lower, of these two faces of the fort were either badly damaged or entirely shot away, and the whole series buried in débris of the most compact, ponderous, and incongruous nature. Huge masses of brickwork or concrete, tons in weight, splintered and broken beams of wood, bars and rails of iron, sometimes entire, heavy guns, carriages, chassis, and platforms, wedged tight with wrecked packages of quartermaster or commissary stores, constituted altogether as chaotic a pile as could be conceived.

It was determined to build a gallery through this mass, so as to bring the north-eastern angle of the fort, where the armed casemates bore on the channel, into communication with headquarters on the western front. There was only one way of doing this, and that was by mining or tunnelling through the long ridge of ruins that lay between the sally-port on the west and the "three-gun battery" on the east. This bold plan was forthwith put in execution, and, although four weeks were required for its construction, the gallery was pushed, through innumerable obstacles, to its successful ending. With a section three feet wide and six feet high it was built, for the most part, of heavy plank, but where the arches of the lower casemates had been crushed in, heavy timber was substituted for the plank. Immovable blocks of solid masonry were cut through; gun-carriages had to be sawed or chopped out of the way; caving of ruined masses had to be encountered, and all manner of delays endured before the work was done. It was two hundred and seventy-five feet in length. Another gallery of the same plan, but of less importance, was conducted by mining at the same time through some of the basement rooms of the gorge, to communicate with the abandoned south-eastern magazine from the direction of the "centre bombproof." The execution was through wet sand and through wetted cotton-bales, except on approaching the magazine, where a pier of solid brick five feet in thickness was met and passed through before the gallery attained its full length of fifty feet. The two chambers of this abandoned magazine became, from this date to the end of the

defense, valuable places of reserve, being used for the storage of provisions.

On the exterior of the fort the mass of *débris* thrown down by the battering of the eastern wall was constantly exposed to the action of the waves, and at times so reduced in bulk as to contribute nothing to the protection of that flank of the work. In rough weather the breakers would dash their spray over the crest of the wall, which was in places not more than twenty feet above high water. To stop the loss of valuable material in this direction a line of iron girders, once flooring-joists, was planted at the water's edge, the irons being set perpendicularly in the crevices of the rocks, and serving, like the posts of a fence, to retain other irons laid horizontally and piled one upon another, so as to retain the *débris* in a kind of permanent footing for the slope above. This retaining wall of irons and solid masses of brick masonry about four feet high proved to be a durable adjunct to the stability of this much-exposed flank. The upright irons were made also to carry lines of wire entanglement above the retaining wall.

In all this time, as the year was drawing to a close, the enemy maintained no more than a weak, desultory fire upon the fort. It was done with 30-pounder rifles from Cumming's Point and mortars from their middle battery. Such firing was always recorded with the severer sort, but it need have no further reference made to it in this history. It served but to mark in its way the ordinary climate of the post.

The commander, always ready to inspire with something of his own buoyancy the minds of his comrades and the garrison, announced his purpose to make preparations for spending a merry Christmas in Fort Sumter. The surroundings were not likely to lend the project aught of the "grace of congruity." Festivities were rare enough at the fort. Nevertheless, some extras were arranged for the soldiers, and the several messes of the officers were gladdened by the receipt of well-packed boxes and hampers from their homes. A notable dinner was spread for the occasion in the head-quarters casemate of the "three-gun battery." For a table the chassis of a 10-inch columbiad, run forward into battery, furnished three irregular lines of support to dishes and plates; for

chairs, it was found that carpet-bags, sandbags, valises, stands of grape, and even round shot, could be used ; while with plentiful supplies of roast turkey, wild ducks, oysters, sweet potatoes, etc. the hardships of life were greatly alleviated. But there was a reminder of grim-visaged war presented that day in the centre-piece of the banquet. It was nothing less than the half of a monstrous shell, fifteen inches in diameter, set in a flattened sandbag and serving for a punch-bowl to the dinner-party.

The Confederates on John's Island had for some time been preparing a Christmas visit to the gunboats lying in Stono off Legaréville. But when they opened on the Marblehead at early dawn of the 25th with some light and some heavy siege-guns, it soon became evident that the navy was not to be caught napping this time, as when the *Isaac Smith* was captured a year before. Though considerably damaged, the *Marblehead* fought well, and, being joined by the *Pawnee* and a mortar-schooner, the three brought the action to a close within an hour, defeating the Confederates, and causing them to leave behind two 8-inch siege-howitzers for a prize to the victors.

About the middle of January, 1864, Lieutenant-Colonel Elliott, for the first time since assuming command of Fort Sumter four months previous, sought a brief respite of one week's absence, leaving Captain Francis T. Miles of the Charleston battalion (Twenty-seventh South Carolina volunteers) in his place. Short as it was, this officer's term of command was distinguished by an occurrence as unexpected as it was agreeable. This was a visit paid the fort by a small party of ladies under the escort of an officer of high rank. Threading the labyrinth of galleries and damaged casemates, clambering over ruined arches up to the very crest of the battered walls, the venturesome party seemed to enjoy the incident. Favored by mild weather, by a clear, moonlight night, and no firing at all, the visit could not have been better timed.

A few nights later and they would have been too roughly greeted, for while the transport-steamer was unloading at the wharf on the night of the 28th of January the enemy opened with mortars quite seriously, following after daylight with heavy rifles and columbiads. The battering fire was first directed at

the south-eastern, and afterward at the south-western, angle. This lasted continuously for three days, or until the 1st of February, and may be recorded as the third minor bombardment. The second was that opened on the fort when the magazine exploded (December 11th). The total of shot and shell fired was 583, as may be more particularly seen in the Calendar of the Appendix. Considerable material was lost by the fort, but repairs every night restored it.<sup>1</sup>

It was during this minor bombardment that another of those gallant feats of flag-raising was performed for which the post was becoming distinguished. As the despatch of the commanding officer well describes the scene, it is best to give it here in full: "At 3 P. M. (January 30th) the flagstaff (at the south-eastern angle) was shot down. It was first replaced upon a small, and afterward upon a larger, staff by Private F. Shafer, Company A, Lucas's battalion, who stood on the top of the sand-parapet and repeatedly waved the flag in the sight of the enemy. He was assisted by Corporal Brassingham and Private Charles Banks of the same corps, and by Mr. Henry Bentivoglio Middleton of the Signal Corps, who is acting as adjutant of the post in the absence of the regular officer. They were exposed to a rapid and accurate fire of shells. At the close of the scene, Shafer, springing from the cloud of smoke and dust made by a bursting shell, stood long waving his hat in triumph. It was a most gallant deed, and the effect upon the garrison was most inspiring." This scene occurred on the same spot as that recorded in the case of Private James Tupper two months previous, and the same remarkable absence of casualty attended it. Like the former, this feat also was made the subject of a general order.

While Sumter was allowed a respite at this time, General Gillmore prepared an invasion of Florida, and made part of his plan to be a diversion in considerable force on John's Island, South Carolina. On February 9th, while he was landing

<sup>1</sup> General Gillmore's head-quarters were at this time removed to Hilton Head, Brigadier-General Terry was established at Folly Island, and Colonel W. W. H. Davis, acting brigadier, was in command of Morris Island with 5000 men and nearly 100 guns.



5000 men under Brigadier-General T. Seymour at Jacksonville, Florida, the Union troops appeared, 2000 strong, on John's Island. They were met a mile above "the haul-over," and resisted stubbornly by Major John Jenkins, commanding a small force, mostly cavalry, and with two guns of Parker's battery (Marion Artillery). On the two following days the Confederates, reinforced by a Virginia brigade under Brigadier-General Henry A. Wise and by a portion of Colquitt's Georgia brigade *en route* to Florida, made a stand at Fripp's house, from three to four miles from "the haul-over," with about 2000 men. The Confederate artillery engaged consisted of two light batteries, Parker's and Charles's, which were effectually served. But it was apparent that the movement was ending on the part of the invaders, for they withdrew from John's Island on the 12th, covered by the fire of their gunboats. Their loss is unknown; the loss of the Confederates was only 17. To favor General Wise, the harbor-batteries were ordered to open vigorously upon Morris Island, and they did so. The concentration of troops by the Confederates, notwithstanding this diversion on John's Island, was so complete in Florida that the victory of Olustee or Ocean Pond on the 20th of February well rewarded General Beauregard for his pains and preparations in defense of his military department.

Another demonstration with the same purpose was made on Bull's Bay. Of 1000 men but few were landed, on account of stormy weather: this was March 8th, and attracted little attention (Davis).

A more serious event of this period was the sinking of the blockader steam-sloop *Housatonic*, carrying eleven guns, off Charleston harbor, February 17th, by a "fish," or diving, torpedo-boat fitted out in Charleston and commanded by Lieutenant G. E. Dixon of the Twenty-first Alabama regiment. This daring officer and his crew of six perished in the attack.<sup>1</sup> After the war the "fish" boat was found at the bottom close to the

<sup>1</sup>The men's names were "Arnold Becker, C. Simpkins, James A. Wicks, F. Collins, — Ridgway, all of the Confederate navy, and Corporal C. F. Carlson of Captain F. W. Wagener's company of artillery." (*Scharf*, page 761.)

wreck of the larger vessel. Captain Pickering of the *Housatonic* was seriously bruised by the explosion, and five others were drowned: Ensign E. C. Hazeltine, C. O. Muzzey, John Williams, Thomas Parker, and John Walsh.

Before operations in Charleston harbor were resumed with any earnestness there was chronicled on the calendar of Fort Sumter one of those pleasant incidents which serve to break through the clouds of war as with a gleam of light and peace. It is mentioned by the authorities of both sides that the 22d of February, 1864, was celebrated with becoming military salutes, the Federal fleet and the batteries on Morris Island joining with the forts, gunboats, and fortifications of the Confederates in commemorating the birthday of George Washington. At Fort Sumter there were doing duty at this time, under Captain James M. Carson, parts of two companies of the Washington Light Infantry (Twenty-fifth South Carolina volunteers). As the day was likewise the anniversary of their organization, it was celebrated by them with the permission of the commander of the post. They banqueted with toasts, songs, speeches, and the music of their favorite brass band (Muller's Eutaw); altogether, with more elegance and completeness, in the then refitted casemates of the western flank, than the head-quarters mess had done two months before when they ate their Christmas dinner in the crowded battery in the opposite quarter of the fort. Doubtless, there were many such festive gatherings under the Union flag that day—significant all that when hostile camps concur in such an observance they are preparing unconsciously for pacification and reunion.<sup>1</sup>

This was the period marked by the introduction of something quite new in the defense of fortresses. A post so advanced as Fort Sumter had become since September was perilously isolated, and on the dark nights greatly exposed to capture from assault. Everything in such a case depended on the promptest manning of the walls to repel attack; and to effect this General Beauregard suggested that a system of bell-ringing be used

<sup>1</sup> The same saluting on both sides distinguished the 22d of February, 1861. Castle Pinckney opened early with a salute of thirteen guns, and at noon the guns of Sumter fired a national salute. (*Genesis of the Civil War*, Crawford.)

throughout the fort to communicate the alarm from the lookout sentinel on the wall or in the breach to the commanders of detachments in the bombproof quarters of the garrison. The plan ordered was executed without delay, and from four points on the crest of the ruins the signal of danger could be transmitted by the sentinel or his officer touching a bell-pull. This at once rang the alarm in the soldiers' quarters down below in the cavernous recesses of gallery and casemate, otherwise only to be reached with a delay that might have proved fatal. The system was maintained in perfect working order from this time in February to the end of the defense in the same month of the following year. It was a mode of alarm as startling as it was complete, and few of the surviving defenders of Fort Sumter in those long watches of the night will be apt to forget the use of those bells, with the turning-out of the garrison to meet a threatened assault.

The spring of 1864 began with a minor bombardment, the fourth of its class. The 15th day of March was signalized by a battering fire of 143 shots directed at the east angle of the fort; and this was the occasion of it: The three armed casemates in this quarter were but poorly protected by their scarp-wall, it having been much damaged in places by both the land and the naval fire. The wall had been strengthened during the winter by a cribwork or grillage on the exterior, ballasted with débris and adding ten feet to its thickness. The material used for the lower coursing was pine timber; for the upper, including the embrasures, palmetto.<sup>1</sup> This work had been prosecuted with as much secrecy as possible, owing to the fact of its being discoverable by the monitors in their most advanced position off the eastern angle. It had no sooner been finished than the discovery was made. The reconnoitring monitor signalled to the batteries of Morris Island, and they opened with their heavy rifles a slant fire upon the extreme right of the structure, where it was built up highest after the manner of a flanking traverse. But, although they splintered and partly demolished it, they did no real damage to the main work, which the traverse was designed

<sup>1</sup> Iron plating had been applied for, but the Navy Department declined to furnish it.

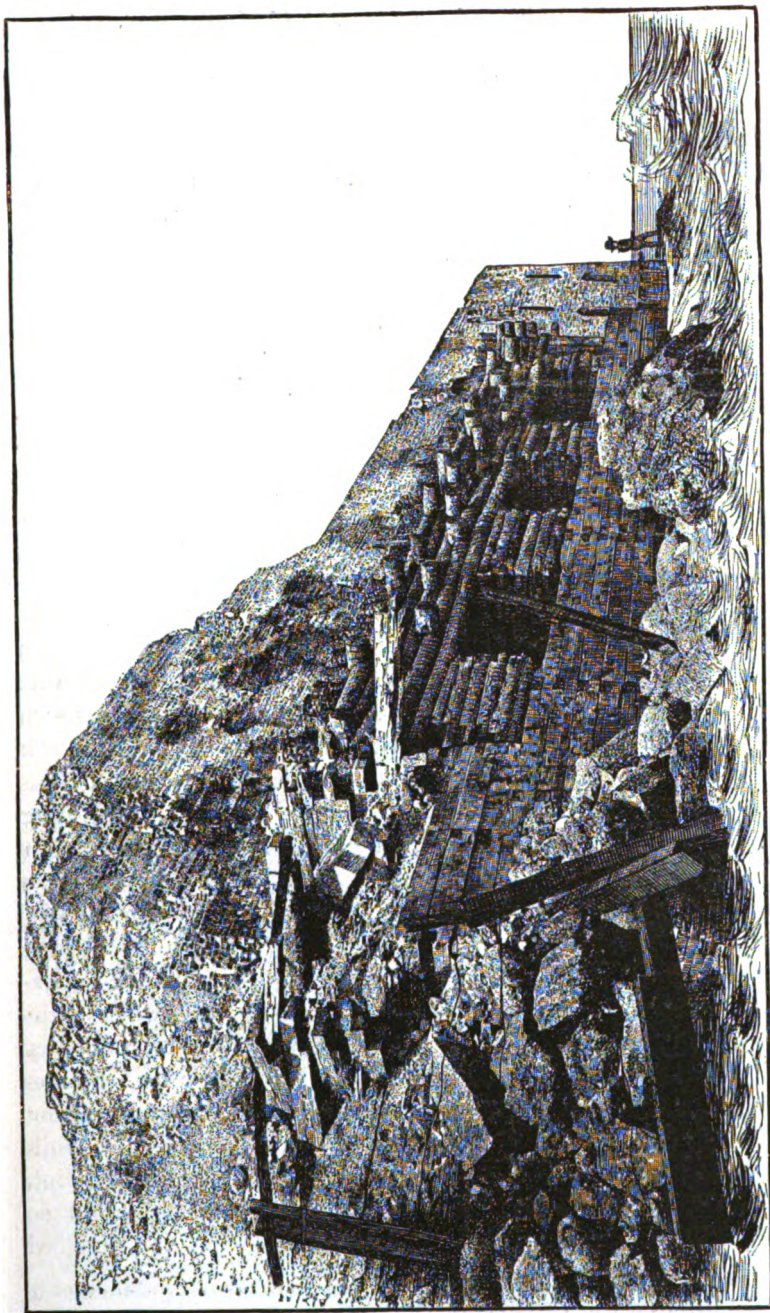

**FORT SUMTER: View of "East Battery" with its Palmetto Shield, March, 1864.**  
(From a photograph.)

to protect.<sup>1</sup> An excellent view of this cribwork is presented among the illustrations, showing the splintered and the unhurt parts. It remained in good serviceable condition till the last. In the foreground, on the left, may be seen the wires and iron girders used for fence-posts to carry the wires by way of obstacles and entanglements to an assaulting enemy. The masses and piles of broken masonry at the water's edge attest the serious demolition of the fort.

Advantage was taken of the comparative quiet at this season to effect at least three important improvements :

1. The ventilation of the casemates of the "three-gun battery," just mentioned, had hitherto been too free for comfort during times of heavy mortar-shelling. It was now, by a covering of stout timber framing and sufficient sand, made to be thoroughly bombproof. The great sand counterfort, or *parados*, covering these casemates from fire in reverse, was raised ten feet higher, so as to protect both the ventilator and the open arches of the second tier of casemates. The battery, in this state protected in front, in rear, and overhead, remained intact and unchanged to the end.

2. The casemates on the city front, next to the north-western angle and the new sally-port, had once been the resort of too many shells from the land and naval guns. In consequence, they became disused and their guns dismantled, and were thoroughfares much littered and encumbered with rubbish. But in honorable exception to the casemates of this vicinity that one on the *pan-coupé*, or truncated angle, was occupied by an indomitable old smoothbore 32-pounder. This gun had served faithfully through all the fort's ordeals, being known as the "evening gun," and being fired to salute the flag when it was lowered every evening at sun-down. It was for seven or eight months the only gun fired in the fort. Its report after sunset on calm evenings would be caught up by the echoing shores of the

<sup>1</sup> It was during this firing that some alarm was felt for the safety of the service-magazine in this quarter. Smoke seemed to be coming forth from its entrance after the explosion of a shell on the outside; and the order was given to John H. Houston, a foreman of the Engineer department, to take twelve men with him and remove the powder; which he did with as cool daring as was ever recorded in war. His services and promotion have been already noticed in Chapter IX.

inner harbor and mellowed in the distance, with somewhat of the sentiment of its own isolation, endurance, and fortitude. In the clearing up and rearranging of this quarter of the fort, made necessary by the explosion and burning of the 11th of December, it was decided to protect and arm these casemates in the vicinity of the "evening gun;" for it was found that with three heavy guns mounted in them a section of the harbor could be covered that was not entirely commanded by either Battery Bee on Sullivan's Island or by Fort Johnson on James Island. Accordingly, the "evening gun" gave place to a banded and rifled 42-pounder; another, of the same calibre, was mounted next on the left; while in the casemate next south of the sally-port a double-banded and rifled 8-inch columbiad was duly installed. These armed casemates were also ventilated, as well as protected, by a covering mass of heavy earthwork on the side of the parade or interior of the fort. Since there were at this time two distinct batteries of three guns each, the old one was henceforth called the "East Battery," and the new one the "West Battery." This latter was completed on the 12th of February.

3. The condition of the parade at one time threatened very seriously the health of the post. Reduced by the excavations to a level three feet below high-water mark, it began to collect in some of its pits stagnant and offensive water.<sup>1</sup> The drainage necessary for sanitary purposes was obtained by sinking a shallow well in the north-western region of the parade, by directing the water of the area through two cross-drains into the well, and drawing out thence, by a pump which emptied through a convenient embrasure into the harbor, all the superfluous or stagnant water in the interior of the fort. These measures were found corrective of the evil; and they were further made effectual by gradually filling up the parade to within two and a half feet of its former level.

The months of March and April passed with very few incidents at the fort. Besides the one day's firing (15th of March) already described, there was one entire night (3d of April) of

<sup>1</sup> Whether from this cause or the crowded quarters, after the explosion and fire in December the garrison was threatened with an epidemic of cerebro-spinal meningitis during the winter of 1863-64.

heavy mortar-shelling, and then, later, at the close of April, several days were distinguished by a novel discharge of mortars, eight or ten in number, firing in volleys, all together, at irregular intervals, and with considerable annoyance to the garrison.<sup>1</sup> This peculiar form of sharp practice was continued into the month of May. By this time the important operations around Petersburg and Richmond were reducing the Confederate army of Northern Virginia. Already, on the 20th of April, General Beauregard had been called away to assist General Lee in front of Petersburg—a service rendered with brilliancy more distinguished than history has yet acknowledged. He resigned the command of the department of South Carolina, Georgia, and Florida to Major-General Sam Jones, a meritorious officer of the armies of Virginia and Tennessee. New officers and troops were daily required for the same field around the Confederate Capital, and the commander of Fort Sumter, himself promoted to the full colonelcy of an infantry regiment near Petersburg, and soon after made brigadier-general, was relieved on the night of May 4, 1864, by Captain John C. Mitchel of the First South Carolina Artillery.

Colonel Elliott had thus performed eight months of arduous service at the post of honor in the entrance of Charleston harbor. He found it a dismantled and silenced fort, a ruined habitation, an exposed outpost, a perilous command. He left it a formidable earthwork, armed with six heavy guns and furnishing comfortable quarters for three hundred men—an outpost still, and much exposed to assault as well as bombardment, but with a proud record of endurance, a long list of brave defenders, and his own name carved high on its invincible front. Inside the harbor preparations of resistance were wellnigh complete: the fortifications perfected by Beauregard and his chief engineer, Colonel Harris, the artillery and garrisons disposed and prac-

<sup>1</sup> On the 13th of April, during some practice between the Federal batteries on Cumming's Point and the Confederate works on James Island, a promising young member of the Signal Corps, Joseph P. Huger, was looking on from the most conspicuous part of the fort, the south-western angle, and thoughtlessly waved his cap when the Confederate gunners made a hit. The action instantly drew upon him the fire of a 30-pounder Parrot rifle from Cumming's Point; the shell exploded with great precision and took off his head.

tised by Brigadier-General Ripley and Colonel Rhett, were without exaggeration models of sea-coast defense, and, for their day, the finest in the world. So must have thought the enemy; for the Federal commanders of both land and naval forces were now hesitating what plan of attack they should next adopt, and even at Washington the heads of departments appeared to be altogether baffled and disconcerted by their want of success before the strongholds of Charleston. (*Memoir of Rear-Admiral Dahlgren*, pages 431, 436, 443.)

*Joint Resolution of Thanks to General Beauregard and the Officers and Men of his Command for their Defense of Charleston, S. C.*

*Resolved by the Congress of the Confederate States of America*, That the thanks of Congress are eminently due, and are hereby cordially tendered, to General G. T. Beauregard and the officers and men of his command for their gallant and successful defense of the city of Charleston, S. C.—a defense which, for the skill, heroism, and tenacity displayed by the defenders during an attack scarcely paralleled in warfare, whether we consider the persistent efforts of the enemy, or his almost boundless resources in the most approved and formidable artillery and the most powerful engines of war hitherto known, is justly entitled to be pronounced glorious by impartial history and an admiring country.

*Resolved*, That the President be requested to communicate the foregoing resolution to General Beauregard and the officers and men of his command.

Approved February 8, 1864.

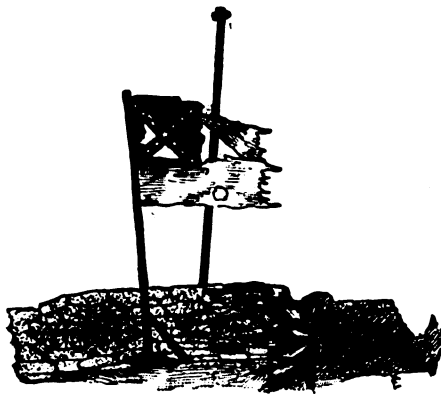

FORT SUMTER'S FLAG, FEBRUARY 2, 1864, AS SKETCHED BY THE AUTHOR. (This was a new one, substituted for the flag of the 29th of January, and torn as above in four days' use. It was flown at the eastern angle of the gorge.)



## CHAPTER XI.

### FORT JOHNSON ATTACKED—FORT SUMTER'S THIRD GREAT BOMBARDMENT.

May 4-July 20, 1864.

THE NEW COMMANDER OF FORT SUMTER, CAPTAIN MITCHEL—GENERAL GILLMORE TRANSFERRED TO VIRGINIA—REAR-ADMIRAL DAHLGREN'S SECOND COUNCIL OF WAR ADVERSE TO ATTACK—SIXTH MINOR BOMBARDMENT—FORT MOULTRIE DISABLES A MONITOR—GENERAL FOSTER SUCCEEDS GENERAL GILLMORE—FLAGSTAFF REPLACED WITH GREAT EXPOSURE—SEVENTH MINOR BOMBARDMENT—GENERAL FOSTER'S PROJECT OF COMBINED OPERATIONS AGAINST CHARLESTON—SKIRMISH ON JAMES ISLAND—ATTACK IN BARGES ON FORT JOHNSON QUICKLY REPULSED—SKIRMISH ON JOHN'S ISLAND—THE MONITORS IN STONO THREATEN BATTERY PRINGLE—CONFEDERATES CONCENTRATE ON JOHN'S ISLAND—SUCCESSFUL ATTACK UPON THE UNION INTRENCHED POSITION, FOLLOWED BY COMPLETE ABANDONMENT OF THE ISLAND—THIRD GREAT BOMBARDMENT OPENS JULY 7TH—SMALL WORKING-FORCE IN SUMTER UNABLE TO REPAIR DAMAGES AT THE FORT—MEN AND MATERIAL REQUIRED AND FURNISHED IMMEDIATELY—CAPTAIN MITCHEL, COMMANDING FORT SUMTER, MORTALLY WOUNDED ON THE FOURTEENTH DAY—RESISTANCE OF THE FORT STUBBORNLY MAINTAINED.

THE new commander of Fort Sumter was Captain John C. Mitchel. A son of the Irish patriot and exile, he had shared with his father the life in Australia and with him escaped to America. Soon after arriving in the Southern States he learned of the approaching hostilities, and, repairing to South Carolina, was commissioned lieutenant by Governor Pickens in the regular artillery of the State service. His first duty was in Fort Moultrie, under Lieutenant-Colonel (afterward Brigadier-General) R. S. Ripley, assisting in the reduction of Fort Sumter, April 12 and 13, 1861. As captain in the First Regiment South Carolina Artillery (regulars) he took part in the capture of the

Federal gunboat Isaac Smith in the Stono River, and later was in command of the works on the southern end of Morris Island when the Federal army and navy combined to capture them. He had become worthily distinguished in the military district, and the choice was generally regarded as promising well for the growing honor of the post. Captain Mitchel was only in his twenty-fifth year at this date. His promotion to a majority had been warmly recommended and was daily expected.

Meanwhile, there had been a change of commanders on the Federal side also. About the 1st of May, Major-General Q. A. Gillmore, after ten months' active service, turned over the operations on Morris Island to his subordinates, Brigadier-General J. P. Hatch and Brigadier-General A. Schimmelfennig, and went North, taking with him troops from this department to a more active theatre of war. But the naval force appears to have not been reduced; the iron-clad squadron of eight vessels was "in good fighting order," and the rear-admiral evinced some disposition to renew the attack. Yet being undecided as to the plan and magnitude of the movement, he convened the captains of his armored vessels on the 10th and 12th of May to consider the question: "Is it advisable to attack Sumter and reduce its power, offensive and defensive, with the present force of seven monitors and the Ironsides, having reference to all the questions involved?" The vote given was seven in the negative to two in the affirmative, and the admiral soon after informed the Department in Washington "that a council of war decided against attacking even the remnant of Sumter."<sup>1</sup> What could have been so formidable in Sumter at this date is hard to conjecture. Yet this decision was the same as that of a previous council held in the fleet October 22d of the year before.<sup>2</sup>

A feeble demonstration only came out of the admiral's aggressive temper at this period. On the 13th, 14th, 15th, and 16th he sent in two monitors each day to take position off the sea-face of the fort, while the land-batteries on Morris Island combined with them in cannonading the work. The fire was kept up at night with the lighter rifles and the mortars, a total of 1140 shots being discharged in the four days, and the casualties

<sup>1</sup> *Memoirs*, Dahlgren, pages 453, 454.

<sup>2</sup> *Ib.*, page 419.

amounting to 1 killed and 4 wounded. This may be called the sixth minor bombardment.

Its effects were confined to the eastern or sea-face, and amounted to some weakening of that quarter, but to no extent beyond repair. Two arched passages adjoining the stair-tower in the eastern angle were required to be filled up entirely to prevent their being breached. One of them had been used as headquarters during the crowding of the garrison in the previous December, and was then protected on the interior, or parade side, by the loopholed blindage of logs shown in the view of that locality (page 181).

But the leading feature of this minor bombardment was the stop put to the monitors by the very effective fire from the batteries of Sullivan's Island. This was altogether done in less than an hour on the fourth day by the timely unmasking of some heavy guns kept in reserve at Battery Bee until that moment. The surprise and chagrin of the Federals were very noticeable, as they had been having an easy time during the previous days. They retired, making signals with the admiral in the most animated manner; one of the monitors having the conical roof of the pilot-house so wrecked and lifted as to present the appearance of a damaged umbrella on a stormy day. Other injuries must have been inflicted, as the practice of the batteries was remarkably exact. This was the last occasion of any fire from the monitors upon Fort Sumter, and, in fact, the last fire of any kind they permitted themselves to receive at the hands of the harbor-batteries.<sup>1</sup>

About this time operations were resumed, rather timidly, by the Union army on the coast. With the purpose of cutting the Charleston and Savannah Railroad where it crossed the Ashpoo River, Brigadier-General Birney embarked sixteen hundred men, mostly colored troops, on three transports, and obtained some gunboats from the admiral to make diversion

<sup>1</sup> Judge Cowley (*Afloat and Ashore*) says: "The last shot at the naval branch of the siege was fired from a rifled gun in Moultrie at the *Canonicus* on the 4th of February, 1865. The projectile was an 8-inch shell, and struck the ship just abaft the smokestack, exploding on the impact, but doing no other harm than cutting away a boat-davit."

for him up the Pon-Pon (or Edisto) River. The expedition occupied two days, May 23d-24th, and terminated in failure, with the entire loss of the finest transport, the *Boston*. This vessel got aground in the Ashpoo, and, being fired on by Earle's Confederate battery, was abandoned in panicstricken haste by her troops, and set on fire by order of the general, sacrificing the lives of sixty horses by this act of desperation.

Toward the end of May three or more attempts were made by small boats at night to reconnoitre the waters of the harbor between Fort Sumter and Fort Johnson; whether to examine the shallow soundings there or to search for the submarine cable of the telegraph, and cut it, could not be determined. The boats were discovered off the south-western angle of Fort Sumter on three several occasions; and once, when fired on, they returned the fire with their howitzers, sending a few harmless shells high over the fort.

General Gillmore's actual successor proved to be Major-General J. G. Foster, formerly the captain of Engineers in charge of Fort Sumter under Major Anderson, sent now to reclaim, if possible, for his Government the prize it had lost three years before. He arrived at Port Royal on the 26th of May, 1864, and immediately conferred with Rear-Admiral Dahlgren concerning their future operations.<sup>1</sup>

An important reduction in the naval force occurred early in June. This was the departure from the blockading fleet of the iron-clad frigate *New Ironsides*. She had been on the station off Charleston since April, 1863, and left finally on the 6th of June for the North. Ever since the attempt, made in October, eight months previous, to destroy her with a torpedo by Captain Glassel of the Confederate navy, great care had been taken to protect the ship against such another danger. The injuries, at first thought to be slight, developed in time and caused her withdrawal from the fleet.<sup>2</sup> There remained of the armored

<sup>1</sup> General Foster was a native of New Hampshire, graduated at West Point in the Engineer corps 1846, was engaged as brigadier-general of volunteers in the capture of Newberne, N. C. He was subsequently brevetted a brigadier-general in the army and major-general of volunteers. He died in 1874.

<sup>2</sup> *Mem. Dahlgren*, page 426. See also Appendix B, under the head of "*New Ironsides*."

vessels seven monitors, two of which were out of order. The rear-admiral writes in his diary at this date that there were *four* iron-clad gunboats opposed to him within the harbor of Charleston. In this he was mistaken, as only three, the *Chicora*, *Palmetto State*, and *Charleston*, were ever in actual service: two or three others were under construction at later dates. (See Chapter I., page 34.)

An instance of great coolness and bravery occurred at Fort Sumter on the 20th of June. The flagstaff had been cut so often by the expert artillerists of Morris Island that a new one had been placed on the crest of the gorge, nearly at its centre and about ten feet above the large bombproof in that quarter. The new staff attracted attention, and, after receiving the compliments of two or three shells from the sharpshooting 30-pounder rifles, it shared the fate of its predecessors. The stump remained fast in the crest of the gorge-wall, while the splintered spar, bearing the flag, was thrown downward upon the top of the "bombproof." In such cases the orders provided that the sergeant of the guard should immediately plant a small battle-flag in the place of the fallen colors. But some little delay occurring, the state of things was observed by Lieutenant Charles H. Claibourne, of the First South Carolina (regular) Infantry, who made for the spot and mounted the ladder with the colors in his hand. Here, in full-length view of the enemy, he began to lash the two parts of the spar together with the halyards, while the enemy, seeing the action, began firing as rapidly as the two cannon could be served.

At this critical moment the ropes, blown about by a high wind, became entangled, and the spectators below were fearing to see the brave officer's life sacrificed by the delay. But two generous and high-spirited men of the Engineer department instantly sprang to the aid of the lieutenant. One, Sergeant N. F. Devereux, mounted the wall and assisted him in the lashings, while the other, Corporal B. Brannon,<sup>1</sup> sitting on the top of the ladder, held the slack of the halyards until the work was successfully achieved. Five or six shells burst close overhead and about their feet or flew past them, but no hurt was

<sup>1</sup> Detailed from Eighteenth South Carolina volunteers, Company G.

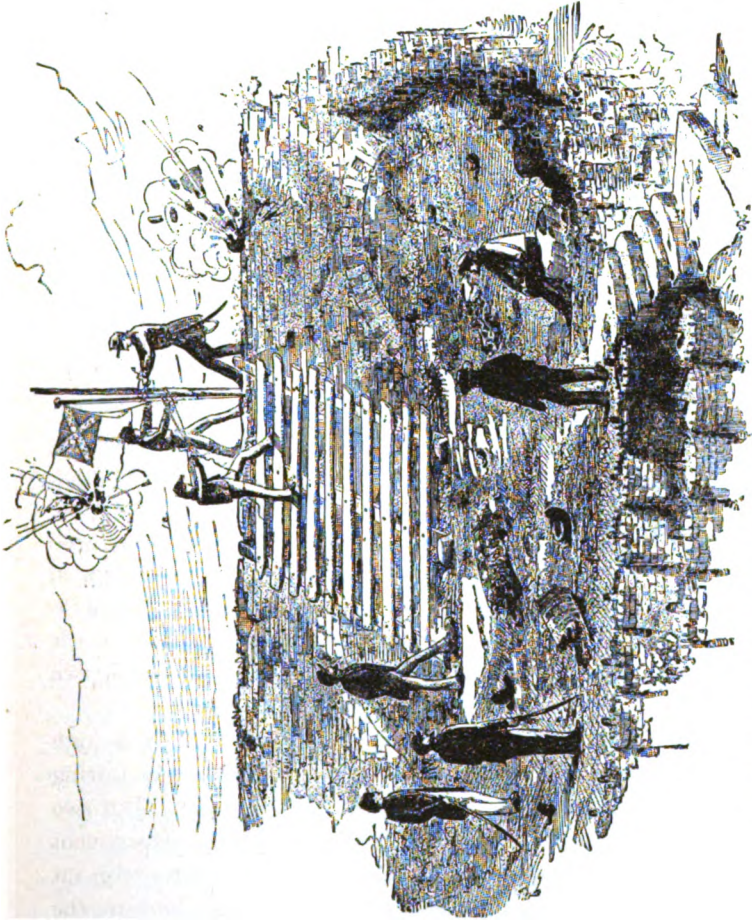

**FORT SUMTER: Replacing the Flag on the Gorge-wall, June 20, 1864.**  
(From a sketch by the author.)

received. The aim of the skilled gunners may have been disturbed by their extreme haste, but the exploding of the shells was not equally under their control, and the preservation of life, due to a higher Power, was remarkably impressive. The actors in this scene were heartily congratulated by Captain Mitchel and others who awaited their descent, and they were, besides, honorably mentioned in department general orders. Among the many like instances at Fort Sumter this case was conspicuous on account of the greatest and longest exposure of person.

The flag was again cut down on the 24th and 27th, and replaced without much risk. But on the 26th of June it was restored under circumstances very like those above narrated, the actors being Privates Walter Steele, Gist Guard, and D. E. Badger, Company I, Twenty-seventh South Carolina volunteers. They were also commended by name in department general orders.

During the next six or seven days the firing upon Fort Sumter was increased to the extent of another minor bombardment—the seventh—being sustained with mortars and the occasional service of the 300-pounder rifle from May 30th to June 5th. Four casualties occurred, but the fort suffered no damage.

The Federal commanders were consulting about this time as to their new plans of combined attack. Once they discussed a project of threatening James Island with the naval force on the Stono River, and at the same time seizing a position on the main land to the rear of Sullivan's Island. This was proposed by the admiral, but opposed by the general. Then, it appears, an expedition against Darien on the coast of Georgia was almost determined on, but soon abandoned. A third enterprise was to cut the Charleston and Savannah Railroad near the Ashpoo River, and then attack in force between Port Royal and Savannah. This too came to nothing. Finally, a concerted movement of some magnitude, having for its object the capture of Fort Johnson and Battery Simkins on the James Island shore of the harbor of Charleston, was planned and adopted. While the fort and battery were to be assaulted, demonstrations were to be made on James Island, John's Island, and the railroad be-

tween Charleston and Savannah. With abundant transportation and the powerful support of the navy, Major-General Foster had at length resolved on a very serious attempt on Charleston itself. The position of Fort Johnson and its adjoining works was on the southern shore of the harbor, which, if occupied by the Union army, would give it at once the key to the whole military situation.

Accordingly, steps were taken in the end of June to organize the plan in five parts. To the navy was assigned the duty of engaging, with two monitors and some gunboats, the heavy battery known as "Pringle," which, in advance of old Fort Pemberton, had been built to dispute the Stono against the armored vessels. It occupied the right of the new and powerful lines built by order of General Beauregard before he left the department. The rear-admiral was expected in this way to lend his strong support to two columns of troops, one operating on John's Island with 5000 men, under Brigadier-Generals J. P. Hatch and R. Saxton, the other moving on James Island with about 2500 men, under Brigadier-General A. Schimmelfennig, who was also charged with preparing the attack on Fort Johnson. The expedition by North Edisto to cut the Charleston and Savannah Railroad was intrusted to Brigadier-General W. Birney. Thus the whole project was of greater importance than any operation on the coast since the siege of Battery Wagner in the previous year.

The movements began with the advance of troops on the southern point of James Island early on the morning of the 2d of July. They were under Colonel William Heine, One-Hundred-and-Third New York volunteers, and had been drawn from Morris and Folly Islands for the purpose of weakening the garrison of Fort Johnson by this diversion. They were met at Rivers's Causeway with a determined resistance by a small force of infantry pickets under Major Edward Manigault of the siege-train, supported by a section of Blake's light battery, under Lieutenant T. M. DeLorme, and held in check obstinately for nearly an hour; but by outflanking the guns before reinforcements arrived they succeeded in capturing them; then, ad-



vancing toward the lines, they intrenched themselves at a safe distance in their front. This movement found the Confederates so weak on James Island that Brigadier-General Taliaferro could not attack, but was forced to do what the enemy desired—withdraw a hundred men from Fort Johnson and wait for reinforcements. To strengthen him a naval brigade from the harbor under Lieutenant W. G. Dozier volunteered, and even the fire department of the city was sent for and temporarily employed on the lines.

While the defenders of James Island were thus called away from the real point of attack on the harbor of Charleston, preparations for it were made at Morris Island by embarking troops in barges on the night of the same day. These, from the command of General Schimmelfennig, were the Fifty-second Pennsylvania volunteer infantry, Colonel H. M. Hoyt, and the One-Hundred-and-Twenty-seventh New York volunteer infantry, Major E. H. Little, together with sixty men of the Third Rhode Island Artillery—a total of nearly 1000 men under command of Colonel William Gurney of the One-Hundred-and-Twenty-seventh New York regiment.

Operating in the narrow, tortuous channels and the shallow waters of this approach to the harbor, their success depended very much on the closest concert of action, and especially on taking advantage of the time of high water. A delay of two hours gave the expedition a bad start. It was near daylight before the boats, obliged to make a circuitous approach to the attack, were in the right position to advance and land the troops. They had been ordered to proceed well within the harbor, and when north of the beach between Fort Johnson and Battery Simkins to “move by the left flank, pull vigorously to land, and assault with the bayonet.” Some of the boats got aground, and were not up with the main body when day began to break and the alarm was given at Fort Johnson.

Lieutenant-Colonel Joseph A. Yates, of the First South Carolina Artillery (regulars), was in command of the post, with a garrison reduced the day before by the withdrawal of a hundred men. He had a hundred left sleeping at the guns of Fort Johnson, and thirty more doing picket-duty at Shell Point, the site

of Battery Simkins, distant in advance south-easterly eleven hundred yards, at the extremity of a low, narrow sand-spit. The main power of Fort Johnson was in its water-battery of seven heavy guns, bearing only on the harbor and entirely un-

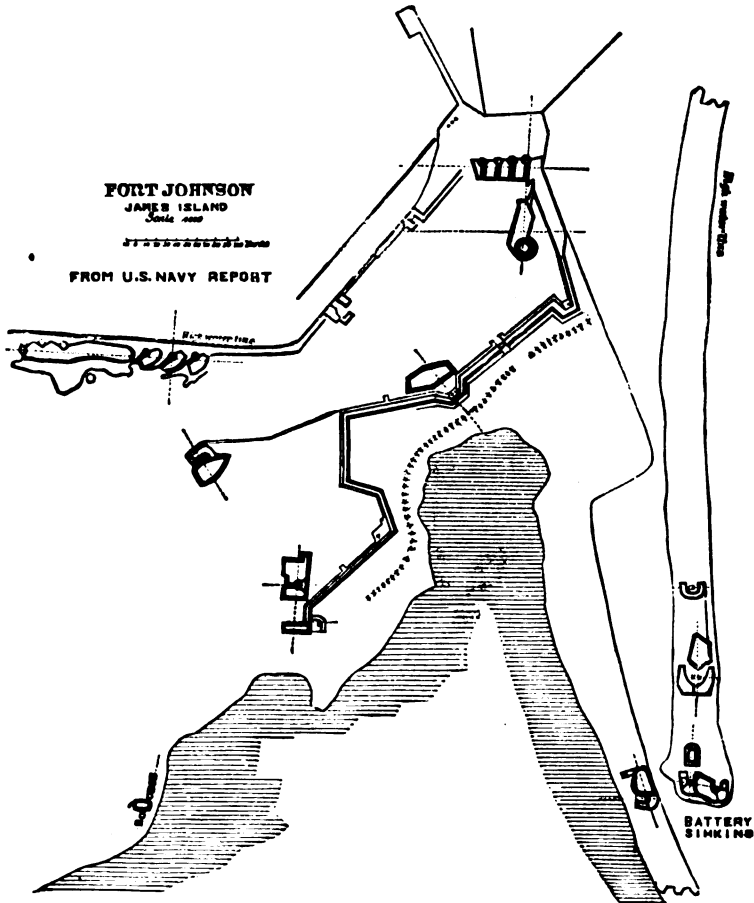

PLAN OF FORT JOHNSON.

fitted to take part in such a defense as was now required. But on the flank about to be attacked were some unfinished parapets for infantry and positions for light artillery. Two 30-pounder Parrott rifles, together with some field-pieces, were mounted

there, and with these fire was opened on the advancing barges. Although suffering little from this fire, the barges were thrown into great confusion, and it is doubtful whether more than half of them really landed their troops. It appears that only the boats commanded by Colonel H. M. Hoyt, Lieutenant-Colonel Conyngham, Captain Camp, Lieutenant Stevens, and Lieutenant Evans, all of the Fifty-second Pennsylvania, and most of the Rhode Island artillerists, the boats commanded by Captain Henry and Lieutenants Little and Abercrombie, all of the One-Hundred-and-Twenty-seventh New York regiment, were brought to shore. The rest wavered and fled. Colonel Hoyt and his men, to what number at that moment is uncertain, moved bravely to the assault of Fort Johnson, having cut off Lieutenant E. Lowndes, in command of the pickets at Battery Simkins.

But by this time the Confederate fire of infantry, as well as artillery from Colonel Yates's little garrison, was beginning to tell on the advance. The fire of the pickets under Lieutenant Lowndes was opened on their rear, adding to the confusion. Their desertion by their friends was soon after discovered, and, although some of their number gained the parapet and fought hand to hand, it was not long before they surrendered.

A large number of those who had landed, however, escaped to their boats and joined their comrades, already retreating on the water. The results were, that 140 Federals, including Colonel Hoyt and five commissioned officers, were made prisoners, five or six barges were captured or destroyed, and the casualties in the assault were 7 killed and 16 wounded.<sup>1</sup> To these must have been added others occurring on the water or concealed by removal to the boats in the act of retreating. The defenders lost 1 killed and 3 wounded in the affair. But the embarrassment with the Confederates was that they were now outnumbered by their prisoners. Lieutenant-Colonel Yates had to order them into his bombproof quarters and fortify himself against their sudden rising. He had more Federals than Confederates in Fort Johnson until the arrival from Charleston of the Citadel Cadets, sent in the emergency to act as a guard for him.

<sup>1</sup> According to general order No. 153, Hilton Head, November 7, 1864.

According to the report of Brigadier-General Taliaferro, the participants in this brilliant affair were Company G, First South Carolina Artillery, Lieutenant T. D. Waties; Company K, of same regiment, Captain Alfred S. Gaillard; detachments of Company E, Lieutenant R. L. Cooper, and of Companies A and E, Second South Carolina Artillery, Lieutenants M. P. Halsey and G. F. Raworth. A company of infantry sent to reinforce the fort and a force of sailors from the armored rams in the harbor are mentioned as having arrived during the action. It has been claimed that the "naval brigade," under Lieutenant Dozier, took the chief part in this fight, but the authority has not been given. The brigade did excellent work in the other operations on James Island, particularly on the Stono River; and its valuable services were acknowledged with complimentary mention by Major-General Sam Jones, commanding the department.

The escaping boats, seen in broad daylight quite distinctly from Fort Sumter, drew on themselves the fire of heavy guns from Battery Cheves on the eastern shore of James Island, and even at long range from the works on Sullivan's Island. Their retreat was extremely hurried while they disappeared up Schooner Creek toward their landing on Morris Island. For a blow aimed skillfully at an important place, and amounting to a surprise in point of numbers, it was delivered with utter feebleness. For a plan well conceived and arranged it was attended with entire failure. Censure was officially passed upon the officers and men who had misbehaved, the commander not escaping for his neglect to accompany the expedition or even to inform his second in command, Colonel Hoyt, of the fact. On the other hand, the vigilance of the Confederates under Lieutenant-Colonel Yates, their spirited defense and complete success, were fitly complimented by Major-General Jones, commanding. They had thwarted an attempt which came very near deciding the fate of Charleston. (See reports, *Southern Historical Society's Papers*, vol. ii.)

But this discomfiture on the 3d did not terminate the operations of Major-General Foster. Directing the movement on John's Island, he landed that same morning at three points

with as many columns converging toward the Stono, so as to gain a position on the right flank, and even to the rear, of the James Island lines. His advance was observed on the 3d and 5th by Major John Jenkins, commanding a small force of cavalry, with artillery under Captain E. L. Parker, subsequently reinforced by some companies of regular infantry from Georgia, under Major R. A. Wayne. But for the gallant resistance of these the artillery might have been captured. Major Jenkins then attacked the rear of their column, marching up the Stono road, at Huntseum's Corner, but hearing of their progress in spite of the cavalry left in their front, he counter-marched eleven miles in haste, and took position to dispute the way at Grimball's Waterloo Place, in the northern part of the island and about a mile from the Stono River.

While this was passing the Federals on James Island were forced back to the southern end by order of Brigadier-General Taliaferro; the naval fire from the Stono upon Battery Pringle and the lines being maintained with vigor "unremittingly for eight days and nights." (*Report of Brigadier-General Taliaferro.*)

The expedition under Brigadier-General Birney, moving up the North Edisto to cut the railroad, had completely failed after landing at White Point and meeting some opposition from cavalry and artillery at King's Creek, below Adam's Run. Hastily withdrawn, these troops passed over to John's Island, where they took part in larger operations.

The Stono batteries on James Island, commanded by Major J. J. Lucas, were kept busily employed with the monitors, gun- and mortar-boats. Battery Pringle lost the temporary use of some guns, but the hard-worked garrison was relieved by fresh artillerists from the forts of the harbor under Major O. Blanding, bringing with them a favorite Brooke rifle, which soon told on the distant boats and obliged them to shift their station. As a last resort, the Federals sent up stream on the night of the 9th, with the tide, three fire-rafts for the purpose of destroying the unfinished bridge across the Stono intended to connect James with John's Island; but the rafts were arrested and the danger averted by the prompt assistance of a detachment from the naval

battalion under Lieutenant W. G. Dozier, who took to the water, boarded the rafts, and brought them to the shore.<sup>1</sup>

On John's Island, at the Waterloo Place, the fighting was resumed on the 7th, and became more serious than anywhere

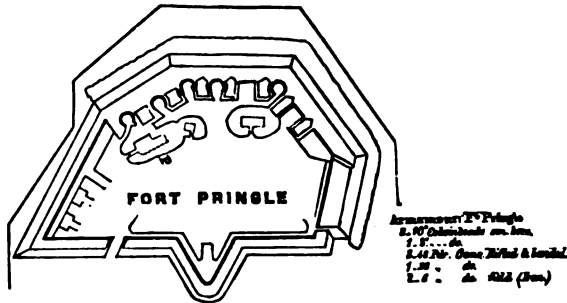

[The Confederate lines of James Island rested on the Stono River at Fort Pringle and Battery Tynes.]

else. The Federal force under Brigadier-General Hatch consisted of 5000 infantry, 100 cavalry, and two sections of artillery at this time. The forenoon was occupied with a sharp engagement between the artillery of both sides, Parker's and Charles's batteries distinguishing themselves for excellent practice, and the afternoon with a flank movement of the Federals. This threatened at first to be successful, but, being bravely and stubbornly resisted by Major R. A. Wayne, commanding the First Georgia regulars, and some detachments of the Second South Carolina Cavalry, under Captains T. H. Clark and A. H. Dean, and by the light batteries of Walter, Charles, and Parker, it failed in its purpose.<sup>2</sup> At length, by order of Brigadier-General B. H. Robertson, who had been sent by Major-General

<sup>1</sup> The officers at the Stono batteries, under Majors Lucas and Blanding, were Captains T. B. Hayne and J. G. Richardson of Lucas's battalion; J. M. Rhett and McM. King of First South Carolina Artillery; Lieutenants W. G. Ogier, W. D. Martin, W. W. Revely, T. E. Lucas, and J. D. Ford of Lucas's battalion; and H. M. Stuart, First South Carolina Artillery. "Lieutenant Ogier is particularly mentioned for his gallantry." (General Taliaferro's report in *Southern Historical Society's Papers*, vol. iii.)

<sup>2</sup> Major Jenkins mentions in his report that Captain Clark held his ground with 21 men, until 7 were killed and 6 wounded, being more than half his company.

Jones to take command of the defense on John's Island, a general assault was made, early on the morning of the 9th, on the intrenched position of the Federals. From this position, dangerously menacing with enfilade the Confederate lines on James Island, the invaders were driven after some resistance. They fell back, rallied, and made a determined stand nearer to their gunboats, but the finishing blow had been given to their campaign. In this assault, while all did well—the artillery as above under Lieutenant-Colonel DeKemper, the cavalry<sup>1</sup> under Major John Jenkins—it was the brigade of infantry from Georgia, the Thirty-second and Forty-seventh regiments and Bonaud's battalion, all under Colonel George P. Harrison of the Thirty-second regiment, that won for itself special commendation for the dash and thoroughness of its work. The Union troops left John's Island that night. The forces of the army and navy were withdrawn from James Island and the Stono on the next day, and only one other attempt on the Confederate works was made.

This was to try again Battery Simkins on Shell Point, in advance of Fort Johnson. About 8.30 P. M. on the 10th of July, the first anniversary of the Federal descent on Morris Island, the work was heavily shelled and attacked by troops in small boats; but only three of these effected a landing, while the affair was speedily ended by small-arms and field-pieces of LeGardeur's battery from Louisiana.

Thus the combinations of Major-General Foster for the capture of Charleston by the way of Fort Johnson, though well conceived, were badly executed. Concerning the ten days' fighting and manœuvring, Rear-Admiral Dahlgren expressed himself very plainly in his diary as having been "utterly disgusted." First, the attack on Fort Johnson failed; then Birney's expedition up the North Edisto failed; then the naval attack on Stono failed, with its connected demonstration on James Island. Finally, the movement on John's Island proved the greatest failure of all. Strange to say, Major-General Foster, after planning so well, chose to accompany the column of Brigadier-General Birney instead of being nearer to the centre of action.

<sup>1</sup> Second South Carolina and Fourth Georgia.







Captain JOHN C. MITCHEL, First Regiment S. C. Artillery,  
Commanding Fort Sumter.—Killed July 20:h, 1864.  
From a Photograph.

(Davis.) The aggregate Union loss in all parts of the field was officially reported to have been 330. The Confederate loss on John's Island was 128, and on James Island 35—a total of 163, only 17 of whom were killed.

Although removed from Fort Sumter, this fighting on the adjacent islands, and particularly at Fort Johnson, involved the safety of the whole harbor, for it was imperilling the communications and threatening to turn or take in reverse all the principal fortifications of the Confederates. The land and naval forces of the attack were strong enough, but they were not pushed with the vigor that characterized the fighting on Morris Island. Had they been, they might have achieved in one week what the toilsome and bloody campaign of Morris Island failed to accomplish after twelve months—viz. the capture of Charleston. On the other hand, the Confederates, though thinly scattered over an extended coast deeply indented with navigable tideways, were ever on the alert, ever ready to contest the advance of their enemy, and did successfully repel all his attacks. This was done by the prompt concentration and placing of troops under Major-General Sam Jones, commanding the department, and by their admirable fighting under their respective commanders.<sup>1</sup>

Thus in the progress of the war Charleston had twice driven back the forces of the Federal navy under DuPont and Dahlgren in 1863, and twice the forces of the Federal army under Benham in 1862 and Foster in 1864. The latter general was next to essay, with enormous expenditure of ammunition, the vain task of destroying Fort Sumter.

#### THE THIRD GREAT BOMBARDMENT.

The garrison of Fort Sumter, now under Captain J. C. Mitchel, had been, for some months past, lulled into a feeling of security. True, the sixth and seventh minor bombard-

<sup>1</sup> Major-General Jones, reporting to the War Office, says: "I am much indebted to Flag-Officer J. R. Tucker for his ready and efficient co-operation. Besides his vigilance in watching the approaches to the harbor, he placed at my disposal a naval battalion armed as infantry. Lieutenant Wm. G. Dozier, C. S. Navy, commanding, which served well and faithfully in the works on James Island; and he also reinforced Fort Johnson with a small detachment."

ments operated to disturb their equanimity, but they did not stop for a day the changes and improvements going on in the fort. These had progressed favorably from one point to another until the strengthening of the much-battered and reduced sea-face of the work came up for consideration. Just as it was fairly begun with the building of cribwork filled with débris, as close under the interior crest of the wall as possible without reducing the height of the crest one inch by caving, and just when the engineers wanted to be undisturbed in this critical stage of their secret proceedings, the heavy fire of a fresh bombardment was suddenly opened on the morning of the 7th of July at five o'clock.

The following extract from the report of Major-General Foster at this date will serve to explain his plans and purposes :

“ Having become convinced that the enemy was strengthening themselves in Fort Sumter and making arrangements for defense, I have concluded that it is necessary to more effectually demolish the walls of that fort. For this purpose I have ordered the bombardment to be renewed to-morrow morning, and all the guns to be so aimed as to breach the wall in a horizontal line on that part of the wall which is now standing vertical. As soon as a good cut is made through the wall, I shall float down against it and explode large torpedoes, until the wall is shaken down and the surrounding obstructions are entirely blown away. I shall continue this until the walls are demolished as far as possible. I am convinced that the fort can, after such a bombardment, be assaulted and taken by boats, and that it can be held without any great loss of life. The only reasons in favor of taking it beyond its occupation by our troops are that it would afford a shelter or starting-point by which boat-expeditions can again attack Fort Johnson or Mount Pleasant. It now serves as a watch-tower to the enemy.”

Had a copy of this report fallen into the hands of the commander of Fort Sumter, it would have greatly surprised if not amused him. Of the only two aspects of the fort visible from Morris Island, one, the gorge, presented nothing but a practicable slope of débris to the water's edge, with not a foot of wall to be seen anywhere on it ; the other, the right flank, or “ sea-face,” as it was commonly called, showed amid the débris of its exterior slope the remains of its wall in irregular masses crumbled down to the level, and in places beneath the level, of the lower

embrasures, an average height above tide of perhaps five feet. How any breaching and cutting of the "wall" of the fort could be found necessary is matter of wonder. There would have been something more than wonder at the proposition, deliberately announced, to shake down the walls and blow away the obstructions by exploding torpedoes near them. But Captain Mitchel was spared the apprehension of such dangers.

Nevertheless, the violence of the bombardment in the first weeks of its outbreak did astonish and even alarm him for the safety of the post. The engineer in charge, Captain Johnson, shared in some degree his anxiety, but only because the working-force had been reduced for some time past below its proper limit and against his earnest protest. It was several days before a force sufficient to repair damages was raised, but as soon as labor was procured the defense fell into the composed routine of previous bombardments. Very great loss of material was to be suffered, but with a hundred and fifty workmen and mechanics the anxieties of the situation were soon allayed. At first the fire, directed at the gorge, left its marks there in deep furrows, flattening the already practicable slope and wasting away much of its substance. Within a week the crest was breached in three places and reduced at one point, the gap previously mentioned, to a height of only twenty feet above the water; a chamber of the abandoned magazine at the eastern end of the gorge was also breached; and the boom, anchored off the south-eastern angle, was broken so as to show an opening of about twenty feet in width.

Preparations to repel assault were made with the utmost alacrity every evening as soon as it grew dark, wire-fencing and entanglements being placed on the slope and the obstructions being doubled at the breaches, while at the gap, where no foothold for the defenders could be provided, a bristling array of wooden pikes was made ready to receive the assailants who might venture to leap down into the parade of the fort. The breached chamber of the magazine was promptly filled, and, making a virtue of necessity, it added new strength and solidity to the gorge in that quarter.

During this first week the most destructive work had been done by the 300-pounder rifle-gun, firing steadily every day

upon the line of the gap in the gorge. The rifle-firing predominated in the day, while the mortar-shelling predominated in the night. The average for the first week was a daily expenditure of three hundred shot and shell. On occasional days the Confederate batteries of James and Sullivan's Islands returned the fire with spirit and effect, causing it to slacken very perceptibly upon Fort Sumter. But they could not expend ammunition lavishly enough to keep pace with Major-General Foster, and so they decided to let him alone. At the close of ten days his direction of fire was changed from the eastern to the western end of the gorge, somewhat to the relief of the defenders, who had been anxiously watching the ravages of the large rifle on its fixed line of fire.

The new firing was maintained with increasing vigor by the use of 200-pounder rifles and 13-inch mortars, the shells from the latter being observed to jar the remaining casemates of the western front very severely through a covering of seven feet. The average total of shots for twenty-four hours in the second week was considerably higher than that in the first, being nearly five hundred. One other feature was the increasing risk from mortar-shelling incurred by the boats and barges used to ply between the transports and the wharf of the fort. They were not unfrequently sunk while landing at the wharf, with loss of life and material. The engineer made requisition for a nightly supply of one thousand bags of sand, so dependent had the fort become on material from without to repair the damages of each day. The casualties were becoming more frequent as the bombardment progressed, and up to the end of the second week they amounted to 6 killed and 26 wounded.

Captain Mitchel, commanding the post, was unremitting in the discharge of all his arduous duties. Allowing himself but little sleep in the day-time, he was particularly alert to guard against assault by night, and the constant vigilance of this spirited young officer became imparted to his whole garrison. Sentinels, straining their eyes from exposed points, were killed or wounded by the shelling while facing the more immediate danger of small boats approaching through the darkness to surprise the fort. In the day-time the sentinels were reduced to one

or two for observation of the fleet and to keep the record of the shots fired.

On the fourteenth day of the bombardment, being the 20th of July, 1864, Captain Mitchel ascended the stairway of the western angle of the gorge, about 1 o'clock P. M., to examine the movements of the fleet and land force of the enemy, preparatory to writing his daily report for transmission to the city by despatch-boat that night. Arriving at the head of the stairs and passing out upon the level of the original *terreplein* of the fort, he found the sentinel there at his post well protected by breast-high shelter within the massive parapet of earthwork necessary to secure the safety of the stair-tower beneath it. Stationing himself near the spot, but not within the sentry-box, he rested his arm and glass on the parapet and began his observations. Before him, in the sea-view, were the low hulls of the monitors lying at anchor off Morris Island, the wooden gunboats and blockaders resting also at their appointed stations outside the bar, and farther out, in the offing, a despatch-boat going North. No movement in the fleet at all that day, except among the tugs and tenders. The sea was smooth, the sky bright, and the sun blazing with midsummer heat. Hot work in the Union batteries of Morris Island close by, their rifle- and mortar-shelling keeping their gunners as busy as they could be; hottest time of all at the battered ruin of a fort taking daily transformation into an indestructible earthwork.

The commander was not unduly exposing himself, but while engaged with his glass a mortar-shell of the largest kind rose in the air, and, descending well to the westward of the fort, as if about to strike the wharf, burst at an altitude of some eighty feet above the water. The bursting of a mortar-shell so high in the air and somewhat outside of the walls was no more to the garrison than a matter of ordinary occurrence, scarcely noticeable in the climate of the fort. The commander continued his observation through it all, his eye fixed to the glass, until suddenly struck to the ground by a large piece of the shell, wounding him with great laceration on the left hip. Had he been in the sentry-box, he would have escaped all hurt, for that was protected on the rear as well as front.

The sentinel at once gave the alarm by calling at the head of the stairs, and was soon joined by one or two from the lower casemates. Lifted from the spot where he fell, pale and much weakened already by the loss of blood, the youthful commander was in perfect possession of his mental faculties and spoke with calmness of his mortal wound.<sup>1</sup> It was a difficult task to bear his body, though of light weight, from the highest point in the fort down to the hospital. The only way was by the dark, narrow, and winding staircase. Tender as the handling could be, the movement yet caused him the acutest pain. When laid on the surgeon's table in the hospital he required to be revived with stimulants. Later, as his suffering increased, anodynes were administered, but no surgery was attempted, as it was seen from the first that his wound would prove fatal. He lingered for nearly four hours, and expired about 5 P. M.

The death of Captain John C. Mitchel, greatly deplored by the many friends he had made in his adopted country, was the closing of a brief career which gave promise of undoubted distinction in military service. He commanded Fort Sumter for two months and sixteen days, passing through two weeks of its third and last grand bombardment. In that time the fears for its safety, which at first he felt, were completely dissipated. Injuries had been repaired, loss of material had been met with new supplies, and precautions against assault had been increased to perfection.

Such was the confidence within, while this was the testimony from without the fort. Under date of July 21st the rear-admiral says in his *Diary*: "I went up in the Lehigh with General Foster to look at Sumter. He said he had not before had such a good view of it. The north-east front still stands erect, and the work is nearly impregnable."

<sup>1</sup> The high-strung spirit of the man and the pride of the soldier spoke out together in the unexpected but characteristic words addressed to the writer at this moment by his fallen comrade: "They have killed me, captain, but I ought to have been a major, though." His promotion, so well deserved, had been highly recommended, and was daily expected by him, but it was never received. Once, when the pain overcame him and he groaned aloud, checking himself, he looked up, attempted to rise, and gave command that the men should not be allowed to pass and repass the hospital, as they were then doing. Later, on being asked what could be done for him, he replied, "Nothing, except to pray for me."

## CHAPTER XII.

### END OF THIRD GREAT BOMBARDMENT—EVACUATION OF SAVANNAH.

**July 20, 1864—February 1, 1865.**

CAPTAIN HUGUENIN SUCCEEDS TO THE COMMAND OF FORT SUMTER—FIRING DIRECTED UPON THE SOUTH-WESTERN ANGLE—MEASURES ADOPTED FOR ITS PROTECTION—CAPTAIN JOHNSON, ENGINEER IN CHARGE, WOUNDED ON THE TWENTY-FIRST DAY—LIEUTENANT WHITE SUCCEEDS HIM—GENERAL FOSTER'S PLAN FOR BLOWING UP THE FORT BY MEANS OF A POWDER-RAFT—COMPLETE FAILURE OF THE ATTEMPT—TWO OTHER ATTEMPTS AND FAILURES—GENERAL FOSTER'S DEVICE FOR ASSAULT WITH ROW-GALLEYS, TOWERS, AND GANG-PLANKS—FIRING SLACKENED—WORK RESUMED ON FORT SUMTER'S DEFENSES AND ACCOMMODATIONS—THIRD GREAT BOMBARDMENT ENDS ON THE SIXTIETH DAY—EIGHTH MINOR BOMBARDMENT—UNION ARMY AND NAVY CALLED OFF TO CO-OPERATE WITH GENERAL SHERMAN AT SAVANNAH—CONFEDERATE VICTORY OF HONEY HILL.—UNION FORCE MAKES LODGMENT NEAR COOSAWHATCHIE—THE CHARLESTON AND SAVANNAH RAILROAD THREATENED—DEFENSIVE LINE OF THE SALKEHATCHIE OCCUPIED BY GENERAL MCLAWS—SAVANNAH EVACUATED BY CONFEDERATE ARMY UNDER GENERAL HARDEE—HE FALLS BACK UPON CHARLESTON—GENERAL SHERMAN OCCUPIES SAVANNAH AND MOVES INTO SOUTH CAROLINA.

THE successor of the lamented Mitchel in the command of Fort Sumter was a young officer trained and graduated at the State Military Academy of South Carolina in the class of 1859—Captain Thomas A. Huguenin of the First South Carolina regular infantry. It has been told how this fine command, under Colonel William Butler, serving as artillerists, had garrisoned Fort Moultrie and the other heavy batteries of Sullivan's Island, sharing largely in the defense of Charleston. In this active service Captain Huguenin had many advantages and opportunities for the display of those qualities which distin-



guished him, and which seemed to fit him for a higher responsibility. He arrived at Fort Sumter and assumed command on the evening of the 20th of July, about three hours after his predecessor had breathed his last. He appeared to be saluted with a particularly heavy shelling by mortars. Two of the supply-barges were sunk at the wharf by the fire that night, and a partial relief of the much-fatigued garrison was effected under great difficulties, but without any loss of life.

The battering went on during the whole of the third week with heavy rifles, assisted by two freshly-mounted 10-inch columbiads, probably of the old Confederate armament turned now against their former owners. The columbiads threw shells into the débris made by the rifles, serving to scatter and lose to the fort many tons of material from the exterior slope of the gorge. And for the first time in the defense the stability of the western angle of the gorge began to be seriously threatened. The remarkable crack on the scarp-wall of the western or city front, near the postern and the western angle of the gorge, which made its appearance a few days after Gillmore's first bombardment began, reaching from the parapet down to the foundation of the fort, was observed at this period to be plainly widened. The determined aim of the breaching-batteries upon this angle, exposed to them as it was only on its gorge side, and serving the defense the important purpose of masking the wharf and communications, could not be mistaken. Already it was becoming reduced in mass of material and weakened by the opening of the extensive crack in its vicinity. All the chambers, casemates, and passages within the angle had been filled, and there remained no other way to further strengthen it than from without the fort. Accordingly, it was determined to raise a cribwork of heavy timbers, in four squares of ten feet each, from the base of the wall upward to at least the height of the lower embrasures. This work would necessarily close up the postern, but it was felt that this opening was no longer necessary, while the advantage of having a check and receptacle at the water's edge for the expected demolition of the western angle of the gorge was seen to be paramount. The work, entirely concealed from the enemy, was begun and prosecuted steadily



Captain THOMAS A. HUGUENIN First Regiment S. C. Infantry,  
Commanding Fort Sumter 1864-65.  
From a Photograph.



up to the level of the arches of the lower casemates, or some twelve feet above tide. About the time it reached this stage the fire of the enemy was happily slackened and its direction also changed. The crest of the gorge and its eastern angle were the next to suffer from the effects of the 300-pounder rifle and its smoothbore allies, the two 10-inch columbiads. Every day for a week the whole of the night's work on the crest of this angle was completely swept away. It had been the position for a long time of a mountain-howitzer, placed there after dark to rake the slopes of the gorge in case of assault. It was found impossible to maintain a parapet there during the day, and accordingly resort was had to a temporary structure every night.

It became evident that the fort was spared through all this time the particular direction of fire which would have been most destructive—viz. that upon the right flank or sea-face, where the protecting mass was lighter and lower than anywhere else in the work. Had the batteries been plied with the same vigor on this as on other quarters of the fort, the consequences would have been almost irreparable. Had even the monitors cannonaded the fort on this flank every night, the effect might have been to cut down the lowest parts to the water's edge and uncover the parade to the eyes of the fleet.

About an hour before daylight on the morning of the 28th of July, while he was inspecting some work on the eastern angle of the gorge, the engineer in charge, Captain John Johnson, was severely wounded by a fragment of mortar-shell striking him on the top of the head. He had been on duty at the fort constantly since the 8th of November, being a period of eight months and twenty days. Lieutenant Ralph S. Izard succeeded him temporarily until the arrival of Lieutenant Edwin J. White of the Engineers on the night of the 30th of July. This officer had long been employed in the construction of heavy works around the harbor, had served frequently at Fort Sumter, and, besides being perfectly familiar with its plan, was known by the chief engineer, Colonel D. B. Harris, to be well qualified to perform the duties of the post. Lieutenant White remained in charge through this bombardment and till the end of the fort's Confederate history.

It was at this period of the bombardment that Major-General Foster made some essays in a novel mode of warfare. It was, as usual, with gunpowder, but with applications that would have been startling if they had not turned out disappointing. Impatient of the slow progress of demolition which he watched from day to day either at his batteries on Morris Island or on board of one of his reconnoitring monitors, he had conceived the design of floating powder-rafts by night close up to the fort and exploding them to the best advantage. In his despatch to Washington, dated July 12th, he wrote as follows: "I propose to make a breaching cut along the line of lower embrasures, and then shake the wall by explosions of large quantities of powder floated down against the fort on rafts. I shall take these rafts up to-morrow morning." Of equal interest is an extract from Rear-Admiral Dahlgren's *Diary*: "*July 21*. . . . It was agreed that the powder-raft should go up in the evening under charge of the Nahant. It was to be veered away when 1000 yards from Sumter. As in all combined operations, things did not work well. At six I noticed that the powder was not in the raft, and sent an aide to see to it. And now the clouds that had been gathering came down in torrents, working in every direction, and with fierce lightning. . . . So it poured till bedtime, and I know not how much longer. Between the mistake and the storm the raft did not start."

It appears from the above that the plan was to tow a powder-raft by one of the "monitors" into some proximity to the fort, on either the eastern or north-eastern front. But the general must have changed his mind as to the point of offense, and determined to start the explosive engines henceforth from the shore. Certainly, no second attempt was made until the evening of the 28th of July, and this was upon the south-western angle on the interior, or the harbor side of the fort, diametrically opposite the quarter first threatened.

The commander of Fort Sumter, Captain Huguenin, relates that about 8.30 P. M. the alarm was given of the approach of some kind of flotilla from the direction of Fort Johnson. The ramparts were instantly manned, the sally-port closed, and an infantry fire opened from the walls upon some very dimly perceived

objects on the water. Captain Huguenin himself repaired to the eastern or opposite angle of the gorge, judging that the real attack would be made in that direction, and that the observed movement was a feint. Scarcely had he taken his position when an explosion occurred off the western face of the fort. The noise was not great, but there was a display of light and smoke that suggested to his mind something quite serious. Hurrying to the spot, he found the troops, under Captain Phillips, unhurt, and no further sign of damage done than a liberal spattering of mud and sand upon the wharf and western wall.

The garrison was kept under arms the whole night, but no further alarm or disturbance occurred. When day dawned there was no discovery made to clear up the mystery, and, there being found no reports of this affair on the Union side, it may never be known what were the particulars of the failure. At the fort it was supposed that a large torpedo had been brought through the creeks back of Morris Island by small rowboats, and then cast loose to float down upon the fort with the first of the ebb-tide from the direction of the inner harbor, but that the explosion was premature. Now that it is known that the object in tow was a powder-raft, it is likely that in the shallow navigation off that front of the fort the raft grounded, and the explosion occurred in a harmless manner. The plentiful casting up of sand and mud seems to justify this conclusion. It may be vain to speculate on the possible consequences of a successful explosion; but the attempt was made on that very angle of the fort which was cracked from top to bottom of its scarp-wall and had been heavily pounded all the week before. The shaking down of this angle, preserving as it did the original height of the wall (forty feet), would have ruined the stairway, unmasked the wharf, and altogether been very disastrous.

It is difficult to surmise what Major-General Foster concluded from this failure, but he refused to be discouraged, for the records of the fort tell how a third attempt of the same kind was made on the night of the 31st of August. A despatch from the commander, dated 4 A. M. September 1, 1864, reports: "The enemy again attempted to blow up the fort with a torpedo,

but failed. . . . The torpedo exploded about three hundred yards off the east angle."

What the other side had to say of this third attempt has not been found. General Foster's reports are few and at long intervals, and the rear-admiral was at this date attending to fleet business at Port Royal. Under date of August 4th the general says: "The slow and careful firing upon Fort Sumter is beginning to exhibit a marked effect: two breaches, one on the gorge and the other on the right flank, are being successfully made; the immense mass of débris that is presented in appearance to our forts is being smashed up and blown away by our shells in a slow but sure manner. In a reasonable time the fort will be rendered untenable, and if still held by the enemy can be taken by our troops at any time we choose."

But the general was very inventive. Besides the powder-rafts, he projected some other structures of still stranger and bolder enterprise. These he describes as follows: "The assaulting arks will be simply modern row-galleys, fifty oars on a side, will draw twenty-six inches of water when loaded with one thousand men; will have elevated towers for sharpshooters, and an assaulting ladder or gang-plank of fifty-one feet in length, operated by machinery. These will be very useful anywhere in assaulting a fort or landing troops in shoal water. I propose also to build a light-draught iron-clad, and have written to General Meigs to ascertain if I can have the railroad iron."

Meanwhile, the fort was growing stronger under the long-continued firing of this third great bombardment. Whenever it was observed that the fire became "slow and infrequent in consequence of the stock of ammunition having given out and none being received" (Foster's despatches), the working-parties at the fort would be emboldened to work by day as well as by night in strengthening the defenses, and particularly in adding material to the much-reduced sea-face, filling in with débris taken from other parts the cribwork on the interior of the same face, which had been waiting for two months for such ballast. Even a new blockhouse was laid out within the line of this cribwork to furnish quarters for a company, and to de-

liver an infantry fire, if necessary, upon the parade. An inspection of the plans and sections of the fort at this period will show that the whole of this new work on the sea-face had to be drawn back of (*i. e. within the lines of*) the old scarp-wall and casemates, these latter having been almost entirely destroyed and swept away.<sup>1</sup>

The bombardment which had begun on the 7th of July, and continued with varying intensity, but without any real intermission, day and night through July, August, and the first week in September, is recorded as having lasted sixty days. A minor bombardment, the eighth and the last of all, ensued for a week longer. The Union general reports on September 19th: "Fire stopped for want of ammunition." Previously to that date it had been only slackened, never stopped. It is probable that along with ammunition he had also been exhausting the powers and endurance of his Parrott rifle cannon. It will be remembered how many of them (twenty-four) had been already expended under Major-General Gillmore. At any rate, there are signs, in the rear-admiral's *Diary*, of the general's arranging to borrow heavy smoothbore guns from the fleet to strengthen his batteries on Morris Island. Four XI-inch guns were accordingly put ashore and mounted. These, with one rifle of 300, three of 200, and one of 100 pounds, with two 10-inch columbiads, twelve mortars of 10 and two of 13 inches, made up what the admiral rates as "the most powerful battery that has been erected against Sumter." But orders must have been sent from Washington not to expend ammunition at such a rate any longer, and this "most powerful battery" remained unused.

It can, therefore, be truly said that the military interest of the Confederate defense of Fort Sumter came to its end with the close of this third grand bombardment. No firing upon the fort but such as may be termed desultory occurred after September, 1864. As in previous cases, a tabulated exhibit of the characteristic facts of this bombardment has been made, and will be found to assist the mind in estimating the comparative value of the attack and defense on this and other occasions:

<sup>1</sup> See Plates after Appendix.



## A TABLE OF FIRING, CASUALTIES, AND DAMAGES.

*Third Grand Bombardment, Sixty Consecutive Days and Nights.*

DATE.	Shot and Shell Fired.	Casualties.
July (from 7th) . . . . .	8,680	8 killed, 40 wounded.
August . . . . .	5,772	5 killed, 22 wounded.
September (to the 7th) . . . . .	214	3 killed, 3 wounded.
Total . . . . .	14,666	16 killed, 65 wounded.

REMARKS.— At first severe and alarming in the absence of a full working-force, the damages were eventually controlled and repaired. Powder-rafts failed entirely to injure the fort. The commander killed on the fourteenth day.

The remaining events of this history, with the exception of the changes and improvements brought about in the fort itself, will be seen to have been shaped so materially by the movements of the Union forces elsewhere as to require some account to be given of the latter.

On the one hand, a plan of operations, military and naval, was formed for the capture of Fort Fisher, the extensive and powerful fortification at the entrance of the Cape Fear River, North Carolina, and of Wilmington, the port which it defended. These operations, covering the time between the middle of December, 1864, and the 15th of January following, terminated with the capture of Fort Fisher on that day.<sup>1</sup> But in preparation for this movement Rear-Admiral Dahlgren was notified, as early as October, that four of his monitors and some gunboats would be wanted for the expedition to Cape Fear; and although it appears that none of these were eventually withdrawn from the station off Charleston harbor, the movement on Fort Fisher determined the policy of the Union forces before Charleston to be henceforth wholly defensive.

On the other hand, the march of General W. T. Sherman through Georgia, and his occupation of Savannah prior to his march through South Carolina, occurring about the same time, required the co-operation of both the land and naval forces in front of Charleston. The rear-admiral himself became much engrossed with the organizing and drilling of a naval brigade

<sup>1</sup> See "Résumé and Conclusion," page 260.

at Port Royal about the end of November, preparing it to take the field with howitzers and marines, and to operate with the gunboats in sustaining General Foster's diversions in favor of General Sherman.

These movements, by the way of the head-waters of Broad River where they approach very near to the line of the Charleston and Savannah Railroad, were aimed to strike the road at two points—Grahamville and Coosawhatchie.

The advance upon the former place was made from Boyd's Neck, a landing only seven miles distant, by Brigadier-General John P. Hatch, commanding a column of 5000 men, including the naval brigade under Commander George H. Preble. Instead of striking the railroad immediately, as could have been done with scarcely any opposition, a whole day, November 29th, was lost by the work of intrenching. This gave time to the Confederates, and enabled them to collect a force of infantry, numbering 1400 from Georgia, together with about 300 cavalry and artillery from South Carolina.

Early on the morning of November 30th the Confederates, under Colonel Charles J. Colcock, advanced in small force—one company of the Third South Carolina Cavalry under Captain Peebles, and one field-piece from Kanapaux's (Lafayette) Battery under Lieutenant Christopher Zealy. This advance was all-important, for time was required to receive and put in position behind some slight works at Honey Hill, three miles from Grahamville, the infantry and artillery, then hurriedly arriving from Savannah and elsewhere.

After advancing a mile and a half beyond Honey Hill, the Confederates met the Union force about eight o'clock, and checked them for a while with some effective artillery practice and skirmishing. When about to be flanked the colonel commanding took advantage of a circumstance that proved highly favorable to the defense. A large field of dry broom-grass separated the combatants. This was instantly fired, and burned furiously with a wind sweeping the flames toward the invaders. By this expedient they were thrown into great disorder, and much valuable time was gained for the Confederates.

So it happened that not until ten o'clock was the position at

Honey Hill attacked by the Union troops. By that time the defenders, marshalled under Major-General Gustavus W. Smith, and ordered directly by Colonel Colcock as to their disposition and fighting, were well prepared to meet them. The result was a complete victory gained by the Confederates. For at the onset and in the series of subsequent manœuvres, including a flank movement on the Confederate right gallantly met and repelled by a charge of the Forty-seventh Georgia volunteers, the Union force was beaten very disastrously, retreating finally to the cover of their works and gunboats, and reporting a total loss of 746 or 754 men—estimated by some to be nearer 1200—killed and wounded. The loss of the Confederates was but 4 killed and 40 wounded.

This victory at Honey Hill, where 1700 put to flight 5000, was one of the most brilliant on the coast. It assured an open road of retreat for Lieutenant-General Hardee from Savannah, and encouraged the troops at Charleston with good prospects of reinforcement.

The distinguished services of Major-General G. W. Smith and his command were gratefully acknowledged by the Legislature of Georgia, March, 9, 1865, in appropriate resolutions. The following is an extract from them: "The State with pride records the gallant conduct of her militia, and feels assured that when an emergency again arises State lines will be forgotten by her militia, and a patriotism exhibited which knows nothing but our whole country."

Most cordially will South Carolina also cherish the memory of that victorious day, when brothers-in-arms stood shoulder to shoulder in her defense, and her own weakening ranks were generously reinforced by the "home guards" of her sister State.<sup>1</sup>

<sup>1</sup> From the *Siege of Savannah*, by Charles C. Jones, Jr., the following note is extracted, with a few changes: "The following organizations were present on this memorable occasion, and constituted the little Confederate army charged with driving back a Federal force more than three times as numerous:

*Infantry:* The First brigade Georgia militia, Colonel Willis.

The State Line brigade (Georgia), Colonel Wilson.

The Forty-seventh Georgia Confederate regiment, Lieutenant-Colonel A. C. Edwards.

The other movement, upon Coosawhatchie, began with a landing of the same troops at Gregorie's Point on December 6th, where they met with some resistance, but succeeded in pushing their way to a position somewhat less than a mile from the railroad. Here they fortified themselves, mounting rifle-guns, with which they vainly attempted to stop the trains and traffic of the road. During December and January they made several advances, but were driven back to their position by the Confederates, the chief engagements being on December 7th and 9th, and the Confederate casualties on those days amounting to 88. The Southern troops engaged were from the Fifth, the Thirty-second, and the Forty-seventh Georgia regiments, the Seventh North Carolina battalion, the Third South Carolina Cavalry, the battalion of cadets from the South Carolina Military Academy under Major J. B. White, together with some militia and reserves, and a battery of light artillery under Captain W. K. Bachman. On the 6th they were commanded by Brigadier-General S. J. Gartrell; on the 7th, by Colonel A. C. Edwards; on the 9th, by Brigadier-General B. H. Robertson—the whole defense under Major-General Sam Jones, commanding, but assisted later by Brigadier-General W. B. Taliaferro from the immediate vicinity of Charleston.<sup>1</sup>

During these operations Charleston harbor had been left for

*Infantry:* The Thirty-second Georgia Confederate regiment, Lieutenant-Colonel Bacon.

The Athens battalion, Major Cook.

The Augusta battalion, Major Jackson.

*Cavalry:* Cos. B and E, and detachments from Company C and the Rebel Troop, all belonging to the Third regiment South Carolina Cavalry, under command of Major John Jenkins.

*Artillery:* A section of the Beaufort Artillery, Captain H. M. Stuart (posted at the centre on the public road).

A section of DePass's light battery.

A section of the Lafayette Artillery (Kanapaux's)."

(For the facts of the charge by the Forty-seventh Georgia and the wounding of Major J. C. Cone and Captain Didge, Co. F, of the same regiment, the author is indebted to the adjutant, B. S. Williams.)

<sup>1</sup> The Confederate force was 5500, of which about 3000 were militia and reserves. Its operations, reported by Major-General S. Jones, may be read in the *Southern Historical Society's Papers*, vol. iii.

upward of three months without threat or disturbance of any kind. Except a slow and irregular fire from Morris Island upon the city at extreme range, extreme elevation 35 to 40 degrees, and bursting charges,<sup>1</sup> there was no firing on either side.

The theatre of war on the South Atlantic coast was now removed to Savannah. That city had been skilfully fortified with the heaviest guns and strongest batteries. The army had abundant time for constructing these, and the experience of the war had been fully used by the Confederate engineers.<sup>2</sup> The navy, too, had been preparing its iron-clad gunboats for river defense. But most of the fortification was against advances from the south and east: on the northern front, approached by General Sherman, there was the obstacle of an inundation, with artillery defenses of lighter construction and more extended lines; in fact, thirteen miles in length. The Confederates, numbering about 10,000, one half being militia or reserves, were commanded by Lieutenant-General William J. Hardee: they resisted from the 9th to the 20th of December, when the order was given with approval of General Beauregard, commanding, to evacuate the city. All troops, with baggage and 49 pieces of light artillery, were successfully withdrawn on the night of 19th-20th, crossing the Savannah on pontoons opposite the city, and falling back upon Charleston. It was not a moment too soon, for General Sherman, having for several days skirmished on the Carolina side, was moving down the river to flank them, and had ordered a division to reinforce Foster in South Carolina, and cut the railroad where he had long been threatening it in the vicinity of Coosawhatchie.<sup>3</sup>

The rear of the retreating Confederates was covered by a division under Major-General L. McLaws, holding the line of the Combahee or Salkehatchie River, where it was strung

<sup>1</sup> The expenditure of rifle cannon in all operations on Morris Island was something extraordinary, being under Gillmore 24, and under Foster 27 pieces; total, 51.

<sup>2</sup> The plans and construction, approved by General Beauregard, were the special charge of Captain (afterward Major) John McCrady, chief engineer of the State of Georgia.

<sup>3</sup> *Siege of Savannah*, Colonel C. C. Jones.



**FORT SUMTER: A View of the Headquarters Casemate. December 7, 1864.**  
(Drawn by Lieutenant J. R. Key, Engineers.)

out for more than twenty miles. This was done until General Sherman, having rested his army in Savannah for over a month, advanced into South Carolina, and forced back these troops upon Branchville, and farther to the Santee River, where it was crossed by the North-eastern Railroad, the only remaining avenue of escape from Charleston.

The whole Confederate force available for the protection of Charleston after the fall of Savannah was reported by Lieutenant-General Hardee to General Beauregard (*Military Operations*, vol. ii. page 341) as being "only 13,700 effectives, infantry and artillery, of whom about 3000 are State reserves and militia." These could not be reinforced from the direction of Wilmington, for that city was beleaguered; nor by the remnants of Hood's army returning from Tennessee and Georgia, because General Sherman was about to march between them and the coast, and he had with him more than five times as many soldiers as the Confederates had in the vicinity of Charleston.

Thus, about the 1st of February, 1865, began that march of General Sherman's army through the interior of South Carolina which inevitably decided the fate of Charleston by causing the evacuation of all the defenses of the harbor and adjoining coast. It would not be too much to say that the campaigns of General Sherman in Georgia and the Carolinas forced the fall of the Southern Confederacy; for the resources of the country, already straitened, were all but exhausted by his depredations, burnings, and destructions. Brave men with tender hearts for their own altars and homes can readily understand how such fighting—if so it can be called—will operate to shorten any war. But while they may recognize the success of the policy, they will never be found to envy the reputation of its advocates nor be tempted to emulate their example. In contrast with the policy and sentiments of General Sherman it is pleasing to quote the noble words of Commodore John Rodgers, replying to an inquiry by a committee of the United States Senate in 1864: "I should be reluctant to burn a house over a woman's and child's head because her husband defied me. Dahlgren, if he burns Charleston, will be called a savage by all Europe, and after the heat of combat is over he will be called a savage by our own people."

NOTE.—The following extract from Lieutenant-General Richard Taylor's work, *Destruction and Reconstruction*, New York, 1883, serves to illustrate an important movement of troops to the battle of Honey Hill:

"The railway from Savannah to Charleston passes near the coast. To lose the Charleston line would seriously interfere with the concentration just recommended. Hardee said that he could ill spare men, and had no means of moving them promptly. I bethought me of Toombs, Smith (General G. W.), and Governor Brown's army. The energetic Toombs had frightened the railway people into moving him, and from his telegrams might be expected before dawn. Hardee thought but little of the suggestion, because the ground of quarrel between Governor Brown and President Davis was the refusal of the former to allow his guards to serve beyond their State. However, I had faith in Toombs and Smith. A short distance to the south of Savannah, on the Gulf road, was a switch by which carriages could be shunted on to a connection with the Charleston line. I wrote to Toombs of the emergency, and sent one of Hardee's staff to meet him at the switch. The governor's army was quietly shunted off, and woke up in South Carolina, where it was just in time to repulse the enemy after a spirited action, thereby saving the railway. Doubtless, the Georgians, a plucky people, would have responded to an appeal to leave their State under the circumstances, but Toombs enjoyed the joke of making them unconscious patriots."—(Chapter xii. page 215.)



## CHAPTER XIII.

### EVACUATION OF CHARLESTON HARBOR.

**January and February, 1865.**

EXHAUSTION OF THE CONFEDERATE ARMIES—SOUTH CAROLINA OVERPOWERED BY INVASION—ODDS AGAINST HER DEFENDERS FIVE TO ONE—GENERAL BEAUREGARD PREPARES TO EVACUATE THE COAST—REAR-ADMIRAL DAHLGREN'S THIRD COUNCIL OF WAR—MONITOR PATAPSCO DESTROYED BY A TORPEDO NEAR FORT SUMTER—GENERAL FOSTER RELIEVED BY GENERAL GILLMORE—UNION FORCES, LAND AND NAVAL, DEMONSTRATE ON JAMES ISLAND—STURDY RESISTANCE OFFERED BY MAJOR MANIGALT IN THE RIFLE-PITS—UNION EXPEDITION TO BULL'S BAY STOUTLY OPPOSED BY THE MARION ARTILLERY, CAPTAIN PARKER—GENERAL HARDEE'S DELAY IN CHARLESTON BECOMING DANGEROUS—ORDER FOR EVACUATION ISSUED BY GENERAL BEAUREGARD, FEBRUARY 15TH—THE COMMANDER OF FORT SUMTER RECEIVES HIS FINAL INSTRUCTIONS—THE FORT TO BE LEFT INTACT—ITS FLAG SALUTED BY THE LAST EVENING GUN—PREPARATIONS FOR REMOVAL—THE GARRISON LEAVES THE FORT BY 11 P. M., FEBRUARY 17TH—ALL OTHER TROOPS WITHDRAWN SUCCESSFULLY FROM THE HARBOR UNDER HEAVY FIRING FROM THE ENEMY—THE CITY EVACUATED EARLY ON THE MORNING OF FEBRUARY 18, 1865.

AFTER the successful evacuation of Savannah by Lieutenant-General Hardee, under instructions from General Beauregard and the approval of the War Department in Richmond, the next question presented was, "How much longer can Charleston be held?" The exigency of the situation, and, in fact, the desperate fortunes of the Confederate cause itself, were becoming daily more apparent.

Against three large and well-equipped armies—that of General Grant in Virginia, that of General Thomas in Tennessee, and this of General Sherman on the South Atlantic coast, menacing three other States of the Confederacy—there was now remaining east of the Mississippi but one well-organized array of

forces, that in Southern Virginia. So little had the South left to oppose the great military power and resources of the North! Imperishable renown had gathered around that army which General Lee commanded, but not even the inspiration of his name could arrest the weakening of its battalions or rescue it from its perilous position. The next march of General Sherman would evidently threaten the communications, not of Charleston only, but also of Richmond and Petersburg as well. With a thoroughly appointed army of 70,000 veteran troops he could now push between the coast, where General Hardee had a column of less than 14,000 unaccustomed to campaign work, and the upper country of South Carolina, where there were no troops save the weary remnants of Hood's defeated army hurrying in detached bodies to make some wished-for conjunction with comrades in North or South Carolina. It is anticipative, but allowable, to record just here that no such concentration was made until after General Sherman had marched quite through South Carolina and been eluded by Lieutenant-General Hardee, leading his troops from Charleston, through Cheraw, into North Carolina.<sup>1</sup>

The first of January, 1865, found Charleston gathered within her circle of defenses—not invested, but much perplexed. Her harbor, well protected against an enemy, had now for four years defied the attacks of both the land and naval forces of the Union. But it was a new thing to have an army of such magnitude as General Sherman's ready to march upon her chief communications, if not upon the city herself.

For some time previous the gravity of the crisis was fully realized both in Charleston and in Richmond. From the latter place General Beauregard was instructed to apply the same principle as had guided him in Savannah—viz. "The defense should not be too protracted, to the sacrifice of the garrison." Accord-

<sup>1</sup> It has always appeared to the writer that a stand against Sherman could have been made on the left bank of the Wateree River in South Carolina. Here, in the vicinity of Camden, General Hardee's army from the coast could have been combined with General Bragg's from Wilmington, instead of seeking a combination at Bentonville, N. C. This would have required an earlier abandonment of Wilmington, but the sacrifice would then have been more profitable than it proved to be a month or so later.

ingly, before being called away to Alabama and Mississippi by General Hood's disaster, General Beauregard left the fullest directions with Lieutenant-General Hardee relative to the impending evacuation of the city.

Meanwhile, the Union army in Savannah rested and enjoyed itself, refitting and reorganizing preparatory to another long march. Both the army and navy commanders before Charleston took frequent opportunities to confer with General Sherman as to his plans and their own. Rear-Admiral Dahlgren mentions in his *Diary* that the general "does not intend to turn off for Charleston or Georgetown, unless forced to do so by unforeseen circumstances. The general urged me not to commit my vessels to the fire of the Charleston batteries."

And yet the admiral, seeing that the war was about to close with little or no naval distinction for his command, manifested at this time some pugnaciousness. For it appears that a third council was held by him and his captains of the iron-clad squadron. Three plans for co-operating with General Sherman were suggested: "1st. Attack Sullivan's Island; 2d. Pass in and attack Johnson; 3d. Run all the way up and attack the city. They were not inclined to go beyond the first step—attack Sullivan's Island. After a full and unreserved discussion, I decided that the obstructions near Sumter should be examined by boats under the supervision of the captains of monitors for each night." That this most obvious duty was not performed long before, under both Dahlgren and his predecessor DuPont, will ever remain a piece of unaccountable, if not unreasonable, neglect. (See Appendix to this chapter.) Better that it had been done long before than postponed to this last moment of the war, for now it cost the admiral very dear.

There were months in the year 1863, after the repulse of the armored vessels under DuPont, when no such things as torpedoes were in place near Fort Sumter. But as the war advanced the use of all kinds of explosives, torpedoes, submarine and subterrene shells, rapidly increased. So it happened that one of the monitors, the *Patapsco*, being on picket-duty for the night of the 15th-16th of January, and "engaged in covering the scout- and picket-boats that were searching the channel for ob-

structions and torpedoes," was almost instantly sunk by the explosion of a torpedo about eight hundred yards below Fort Sumter, and nearly on a line connecting the fort with Battery Beauregard on Sullivan's Island. The lieutenant commanding, S. P. Quackenbush, with four officers and thirty-eight men made their escape, but sixty-two others were carried down by the sinking vessel. This monitor was quite a veteran, having been the fourth in line on the 7th of April, 1863, a frequent opponent of Battery Wagner during its protracted siege, and the hardest fighter of the 8th of September, when, after two hours and a half, she was towed out of action with the heavy works of Sullivan's Island much the worse for exposure. The Patapsco was the third of the armored vessels sunk off Charleston harbor, the Keokuk and the Weehawken having gone down the year before.

Toward the end of January, General Sherman was ready to move from Savannah. For purposes of diversion and co-operation he conferred with Major-General Foster and Rear-Admiral Dahlgren, and favored, or rather specially urged, one of the movements, a descent on the main land at Bull's Bay, about twenty miles north of Charleston (*Memoirs Dahlgren*, page 493), while no doubt agreeing to the other operations of the general plan.<sup>1</sup>

So the gunboats were ordered to be active on the flank of the Confederates; and first, on January 26th, the Dai-Ching, proceeding up the Combahee River (called, higher up, the Salkehatchie), was stopped by a battery of heavy guns on the left bank at a place known as "Burnet's." In attempting to escape she ran aground, was set on fire by her commander, and was totally destroyed. Next, a brigade under General E. E. Potter, supported by the steam-sloop Pawnee and the gunboat Sonoma, threatened the Confederates by landing at White Point, up the North Edisto River, January 30th, and pushing a few miles toward Adam's Run; but being met with resistance by a light

<sup>1</sup> On the 24th of January General Sherman wrote to the Admiral: "Tomorrow I will demonstrate on Salkehatchie, and will be obliged if you will feel up Edisto or Stono, just to make the enemy uneasy on their flank, and develop if he intends to hold fast to Charleston and Columbia both."—(Report Secretary of Navy, 1865.)

battery strongly posted at King's Creek, the troops withdrew to the ships that evening. In this vicinity of the Combahee and Edisto, Toogoodoo and Wadmalaw Rivers, diversions like these were continued until about the 10th of February, before which time Sherman's army was all in hand on the Carolina side of the Savannah River and marching upon Branchville, sixty miles west of Charleston.

At two points nearer the city the demonstrations were more decided, being in larger force and attended with some fighting. Before they occurred Major-General Foster, after serving in command of the department for eight months, was relieved by Major-General Gillmore, who returned to his former post February 9, 1865, in time to co-operate with his old colleague, the rear-admiral, in the movements now to be described as occurring on James Island, contiguous to the harbor, and on Bull's Bay, about twenty miles north-east of Charleston. Although they were both combined attacks, the land force had most to do on James Island, while the naval force was more prominent at Bull's Bay. These were the last struggles in the defense of Charleston.

The scene of the action on James Island was nearly the same as that of the previous summer, being the southern point of the island, where the Stono and the Folly Rivers approach each other. The Confederate lines and batteries were all as before, with heavy artillery and ammunition, but the light batteries and infantry troops had been moving to the rear for some days, leaving but a scant force of pickets to man the rifle-pits. These extended almost from one river to the other, were nearly two miles in advance of the fortifications, and were accessible to the enemy on the side of Stono by Grimbald's Causeway; on the other side by Rivers's Causeway. Lieutenant-Colonel James Welsman Brown at Secessionville, with Major Edward Manigault of the South Carolina Siege-Train in advance, second in command, had been left to defend the ground.

While matters were in this condition the attack was begun early on the morning of February 10th by a heavy shelling from two gunboats in Folly River and two others in Stono, the latter being soon joined by the monitor Lehigh. From the

Union forces on Morris and Folly Islands, under Brigadier-General Schimmelfennig, two regiments with field-guns and two companies of skirmishers, commanded by Colonel A. S. Hartwell, moved on the Confederate outposts by the way of Grimball's Causeway, on the right of the line, skirmishing and advancing twice to the attack. Here Major Manigault, receiving orders to hold on to the last extremity, made a stubborn defense. He had, all told, but 131 men, only 80 being in front at the rifle-pits, with no light artillery at all; and he held those rifle-pits for four hours, until over one-third of his little force was either killed, wounded, or captured, he himself being severely wounded and made a prisoner.<sup>1</sup>

The pits were carried by a front and flanking charge about 3.30 P. M., though not without a loss to the enemy of upward of 90 men. The position, however, was not held, for the troops fell back to the cover of their gunboats the same evening, and did not again advance. But the naval fire was continued all night, and for several days and nights, particularly on the 14th and 17th, during which the little band of Confederates on James Island was kept in all the harassing excitement of a most arduous service. They were the rear-guard of General Hardee's withdrawing forces, and he could have had no better men.

Bull's Bay appears, to a superficial observer of the map of the coast, to be an excellent base of operations against Charleston. It had often been proposed and discussed from the very first period of the war, but had just as often been dropped out of plans and calculations. Any examination will prove its chan-

<sup>1</sup> The Confederate force engaged under Major Manigault consisted of the Palmetto Guard, Captain B. C. Webb, Lieutenants W. H. Chapman, James A. Brux, and Robert E. Mellichamp; the Cobb Guard of Georgia, commanded by Captain Turnipseed; and a company of the Second South Carolina Artillery, commanded by Captain Kennedy and Lieutenant Charles Rush. The following casualties in the Palmetto Guard have been furnished by Captain Webb and Lieutenant Chapman, to whom I am indebted for other particulars: Killed, Corporal W. P. Nagle, Private C. H. Kerr; wounded, Lieutenant J. A. Brux, Privates P. G. Langley, P. T. Drayton, A. O. Pansin, C. A. Aimar, J. L. Fair, J. W. Zorn; wounded and captured, W. L. Campbell, A. R. Haig, W. W. Houston, W. R. Mouzon; sick, captured on the field, John T. Humphreys, James A. Bowie, Alexander Bowie; total loss, killed, wounded, and captured, 2 officers and 34 men.—J. J.

nels narrow, its roadstead contracted, its waters shoal, and its shores fringed with wide marshes, making the approach to them quite difficult. But General Sherman seems to have prevailed on the commanders before Charleston to fit out an expedition to the bay, as though expecting larger results from this quarter than from any other. After General Foster left the department, General Gillmore took up the project and entered into it with Rear-Admiral Dahlgren with some appearance of earnestness. To land a column there and drive the defenders down the coast, upon the main land to the rear of Mount Pleasant and Sullivan's Island, promised well for final operations against the defiant city.

A land force under Brigadier-General E. E. Potter was accordingly conveyed to Bull's Bay by several army transports on February 12th, supported by a flotilla of seven gunboats, "three armed tugs, thirty-three boats, and thirteen pieces of artillery," under Commander F. Stanly of the navy. The rear-admiral himself went to direct, until summoned elsewhere the same day by a despatch from General Sherman. The early morning outlook from the mastheads so suddenly congregated at the northern point of Bull's Island could not have been very satisfactory. The shores of the bay proper exhibited no favorable bluff for landing as seen three or four miles distant to the north-west and losing themselves in enveloping marshes. A little earthwork may have been discovered at Graham's Point, where Owendaw Creek enters the bay at its extreme northern limit, admitting small craft to the low bluffs and landings. But nearer by half, and much more promising, were the shores of a smaller bay to the westward, separated from Bull's Bay by a stretch of marsh, but seemingly an appendage of the larger sheet of water. This was called Sewee Bay,<sup>1</sup> and on its open

<sup>1</sup> This bay was the scene of an action in colonial times (1706), when the French expedition under Le Feboure threatened Charleston. After his ships had been driven from the harbor, news was brought to the governor, Sir Nathaniel Johnson, that a fresh landing had been made in Sewee Bay. A force under Captain Fenwicke was immediately despatched by land, *via* Haddrell's Point, and another by sea, consisting of two armed vessels under Colonel William Rhett. The former, arriving first, met with some resistance from the French, but soon caused them to take to their ships, when, meeting

shore were two miles of bluff dotted with the summer-houses of a little settlement known as Andersonville. The great advantages of this landing commended it at once to the expedition, for, besides presenting open shores, it was at once both nearer to the fleet and nearer to Charleston than Bull's Bay.

The Confederates meanwhile had not been idle, but collected in good time, from Mount Pleasant and elsewhere, a small force, between 200 and 250 men, consisting of the Marion Artillery, with four Napoleon guns and two small companies of infantry, the whole under Captain Edward L. Parker of the light battery. They occupied some rifle-pits and sunken batteries of the slightest construction along the shore of Sewee Bay, while farther to the north, where Owendaw Creek entered Bull's Bay, there was also a similar force, posted to defend that approach to the main land. Such were the troops which constituted the last of the coast-guard and disputed the landing of a formidable expedition.

With these slight elements of a problem before the minds of its leaders the expedition appears to have been singularly non-plussed, for it was four days occupied in finding a place to land its troops. On the morning of its arrival Brigadier-General Potter, with Captains Stanly and Balch of the navy, advanced in two columns of barges armed with howitzers to make a reconnoissance of the Andersonville shore. But they came no nearer than a mile of it, firing some harmless shells at Captain Parker's battery, but receiving from him some well-directed shots, of which one struck and disabled a boat-howitzer. What with this warm reception and the tortuous navigation, they advanced no farther, and after getting aground in many directions withdrew for the day. One of the gunboats, the Ottawa, succeeded, however, in gaining a position from which to shell, at long range, the shores of Sewee Bay, and did so with sound and fury, but with no real disturbance to the Confederates.

The following days were occupied with soundings and reconnoitring in other directions; but not until barges were sent up

Colonel Rhett by water, they surrendered without firing a shot. The prize, with 90 prisoners, was brought into Charleston harbor. Among the officers captured was Monsieur Arbuset, said to be the commander of the land forces of the expedition. (See Ramsay's *History of South Carolina*, vol. i. ch. v.)



to Owendaw Creek on February 16th, and the evacuation of Charleston had begun, did Brigadier-General Potter make his descent on Bull's Bay. This gave time to Captain Parker with his battery and infantry support, joined at the last by Kirk's Rangers and some dismounted cavalry, to withdraw into the interior on the night of the 15th by the way of Huger's bridge on the eastern branch of Cooper River.

While these movements of the Union forces were in progress, threatening the Charleston and Savannah Railroad on the west, James Island on the south, and Mount Pleasant, *via* Bull's Bay, on the east, Lieutenant-General Hardee was hastened by General Beauregard to begin the evacuation of Charleston, which had been agreed upon as early as the 2d of February. The delays that occurred seemed unaccountable to the latter, and on visiting the city on the 14th he issued final memoranda of orders to Lieutenant-General Hardee, concluding with these paragraphs :

"In view of the facility the enemy has at Branchville and Orangeburg, and in the direction of Columbia, to cut the line of retreat of the garrison of Charleston, as above referred to, it becomes necessary to commence the evacuation as soon as the necessary preparations can be made.

"The holding of Charleston is now reduced to only a question of a few days. Its loss does not jeopardize the safety of the State of South Carolina, but the loss of the garrison would greatly contribute to that end.

"G. T. BEAUREGARD, *General.*"

Again, from Sumterville, February 15th, he sent a peremptory order to Lieutenant-General Hardee to "commence immediately movement as arranged," and the latter replied the next day that it was to be then begun and carried out. Unfortunately, the lieutenant-general was himself taken sick, and Major-General L. McLaws being sent for, further delay was incurred, so that "the evacuation was not effected until the night of the 17th and the early morning of the 18th of February."—(*Military Operations of General Beauregard.*)

It is not apparent that any important concentration of forces in front of General Sherman before his entrance into Columbia could have been secured by an earlier evacuation of Charleston. But the delay was dangerous, and became more so as the troops

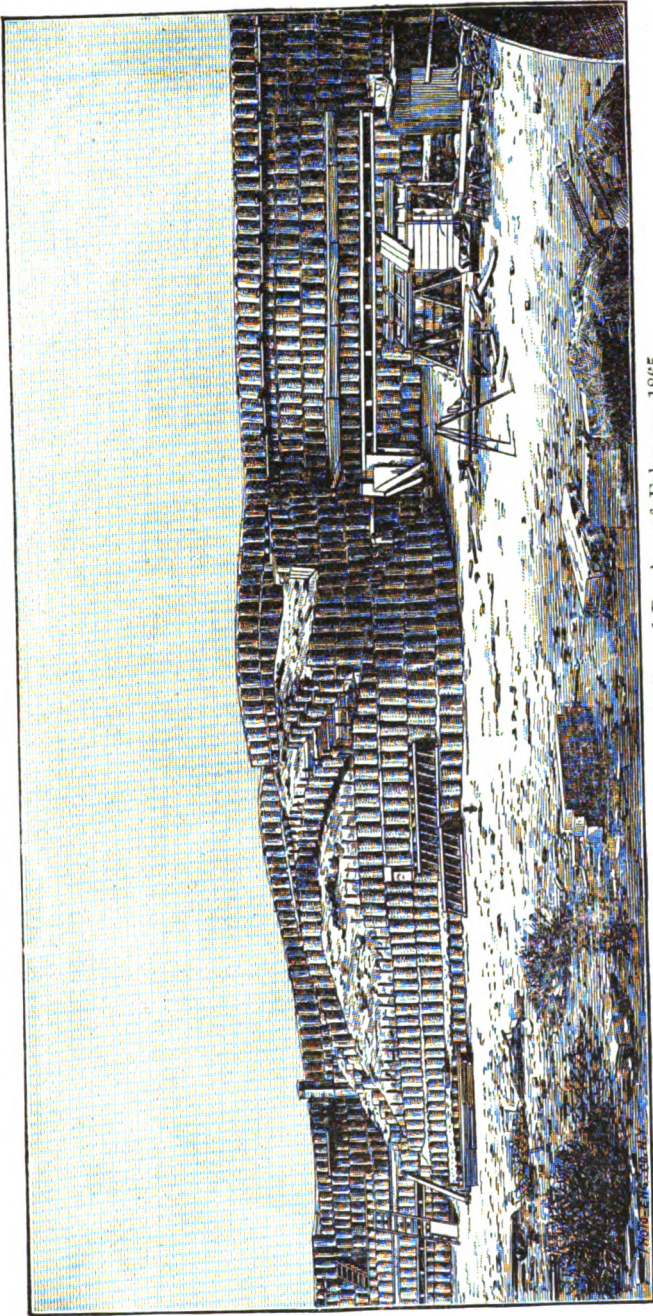

INTERIOR OF THE GORGE: Central Bombproof, February, 1865.

retreating from the coast by the line of the North-eastern Railroad, *via* Florence and Cheraw, approached the latter place. Here they had barely time enough to cross the Pee Dee River and burn the bridge in the face of General Sherman and his resistance to their rear-guard at that point.

It now remains to fill out with some particulars the closing period of the history of the defense of Fort Sumter. The last and longest continued of its three principal bombardments was seen, in the previous chapter, to have terminated in the early part of the month of September, 1864. During the remainder of that month and through October and November the records of firing indicate that it became more and more desultory, averaging about thirty shots per day. When, in December, the march of General Sherman upon Savannah called for the co-operation of both Union forces before Charleston, Fort Sumter had entire respite from the enemy, occupied elsewhere on the coast. Only seven shots were received in December and sixty-four in January, and none at all in February.

Thus the question of the fort's impregnability was at length settled. It had, in fact, silenced the very guns which once had silenced it. No less than fifty-one rifle-cannon of the heaviest calibre and of the costliest make were expended<sup>1</sup> (worn out or burst) in the firing from Morris Island upon the works of Charleston harbor and the city itself. The share which Sumter had in that firing was worthy of such a post of honor, worthy of such a lion-like resistance, followed by such protracted endurance, as distinguished its defense.

But, though not to be surrendered, the fort was finally to be evacuated, together with all the other works on the coast of South Carolina—a result forced, as has been seen, by the march of General Sherman at the head of an army of 70,000 veteran troops through the State from Savannah to Columbia, from Columbia to Cheraw; and by the exhausted resources of the Confederacy itself.

The commander of Fort Sumter, Captain Thomas A. Huguenin, had for a long season of undisturbed possession seen the reliefs

<sup>1</sup> Supplementary report Gillmore's operations, page 34. Twenty-four were expended by General Gillmore, and twenty-seven more by General Foster.

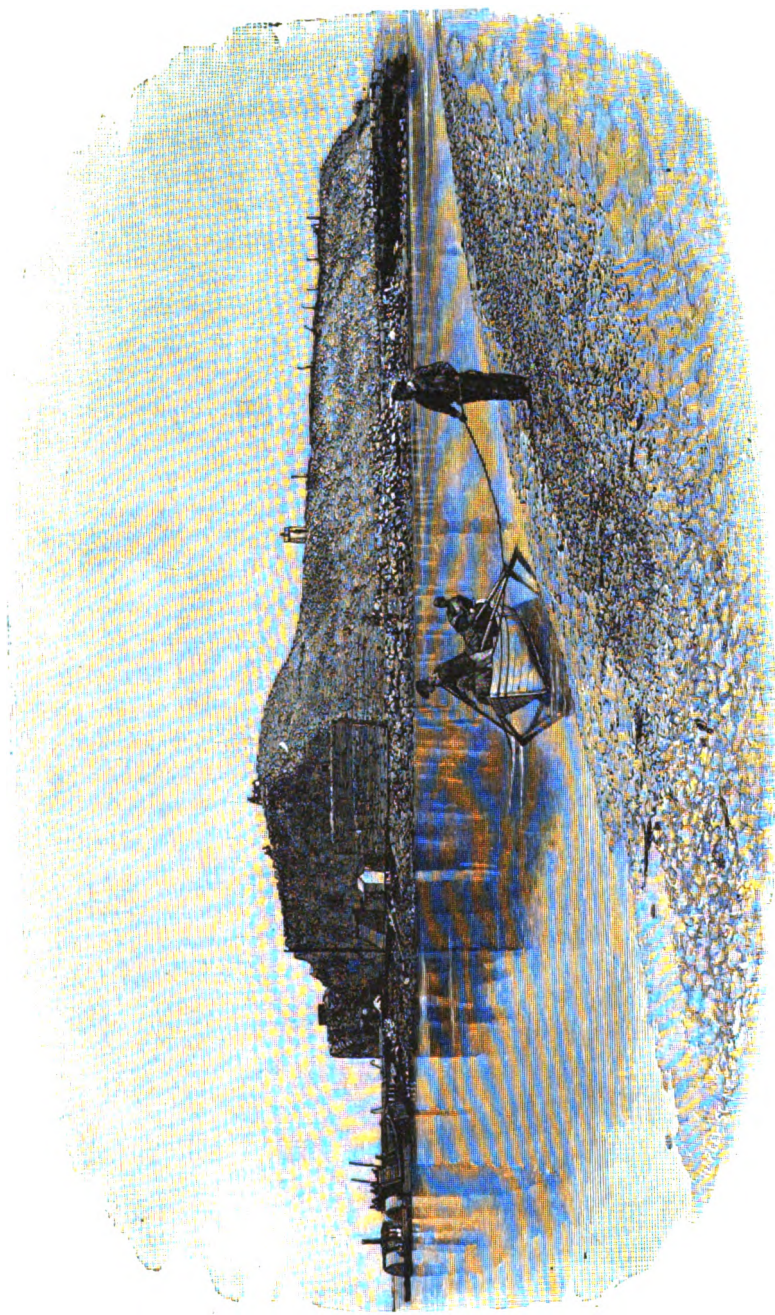

**FORT SUMTER: View of the South-western Angle and the Gorge, February, 1865.**  
(The shoal in the foreground is covered at high water.)

of his invincible garrison come and go, while the labors of his engineer force were adding strength, accommodation, and even finish, to the powerful earthwork into which the ruined brick fort had been transformed. He felt—and the city, the State, the whole Southern country felt with him—a lofty pride in maintaining this post made illustrious by so much bravery, skill, and persistence. Though the sounds of war had died away around the harbor through all that winter of 1864–65, and the flag of Sumter, flung to the breeze every morning, had been daily lowered with the saluting of the evening gun, the time was drawing near for the termination of its defense and the furling of that flag for ever.

It was on the 16th, two days before the city was evacuated, that the commander received a telegraphic despatch from headquarters ordering preparations to be made at the fort. Detailed instructions were received that evening, and in accordance with them the sick, the negro laborers employed by the engineer department, servants, and the baggage of the officers were that night sent up to the city.

On the morning of the 17th a new battle-flag was hoisted: it was the last flown from the walls of Confederate Sumter. During the day all officers were informed of the expected movement, and ordered to have their companies in readiness for embarking on the boats that night. The day passed wearily and sadly to all who felt the crisis of the cause they had perilled their lives to maintain, and who understood the significance of abandoning such a post in the defense of Charleston and its harbor. Troops from the neighboring States of North Carolina and Georgia had often done duty within those walls, as at Battery Wagner, Morris Island, and elsewhere around the city. There were none at this time from the "Old North State," but, together with two companies of the First South Carolina (regular) Infantry, there were three companies from the Thirty-second Georgia volunteers in the garrison.<sup>1</sup> It will always be remem-

<sup>1</sup> The record of this fine command, and particularly of its distinguished colonel, George P. Harrison, Jr., has been frequently and honorably made in the defense of the Carolina coast. On James Island, John's Island, Morris Island, at Fort Sumter, as well as around Savannah, and notably at the victory of Olustee in Florida, the regiment and its colonel deserved the highest praise.

bered by the Carolinians of Fort Sumter that there were with them at the close of its eventful career comrades from a sister State who had long exulted with them in its possession and could now feel with them the pain of its sacrifice.

With the going down of the sun the flag was lowered and the last evening gun pealed its salute over the waters of the hitherto inviolable bay. To the latest moments of the fort's resistance vigilance prevailed, causing the preparations for assault after nightfall to be made just as usual. The sections of wire-entanglement and of bristling wooden pikes which formed obstructions on the practicable slopes of the gorge and sea-face, and had been nightly placed for seventeen months, were lifted and set with customary care by the engineer force. The light brass howitzers, which were to be so servicable and important in the event of another attack by barges, were run up by the ramps and put in positions on the crest of the work, long established by the artillerists. Even the closing and fastening of the shutters to the embrasures in the casemates, where heavy guns frowned upon the channel, was not forgotten. The sentinels of course were posted on the walls, and on the wharf there was a special lookout kept for the arrival of the transport-boats. As the evening advanced the entire garrison, except the sentinels, was formed ready to move the moment the arrival of the boats should be reported. The total number of officers and men was about three hundred.

Toward ten o'clock two small steam-transports reached the fort, in charge of Lieutenant Thomas L. Swinton of the quartermaster department, long entrusted with this difficult and responsible night-service on the harbor, and thoroughly efficient in its performance through storm and rain, through shot and shell. Then the roll of the garrison was called, and the order was given to march aboard. The commander, accompanied by Lieutenant E. J. White, engineer in charge, and Lieutenant W. G. Ogier, adjutant of the post, proceeded to the ramparts and personally relieved the sentinels, who were sent aboard the boats.

On Captain Huguenin had twice devolved the unpleasant duty of being the last to leave a well-defended post. Here, as at Battery Wagner in the summer of 1863, the evacuation was

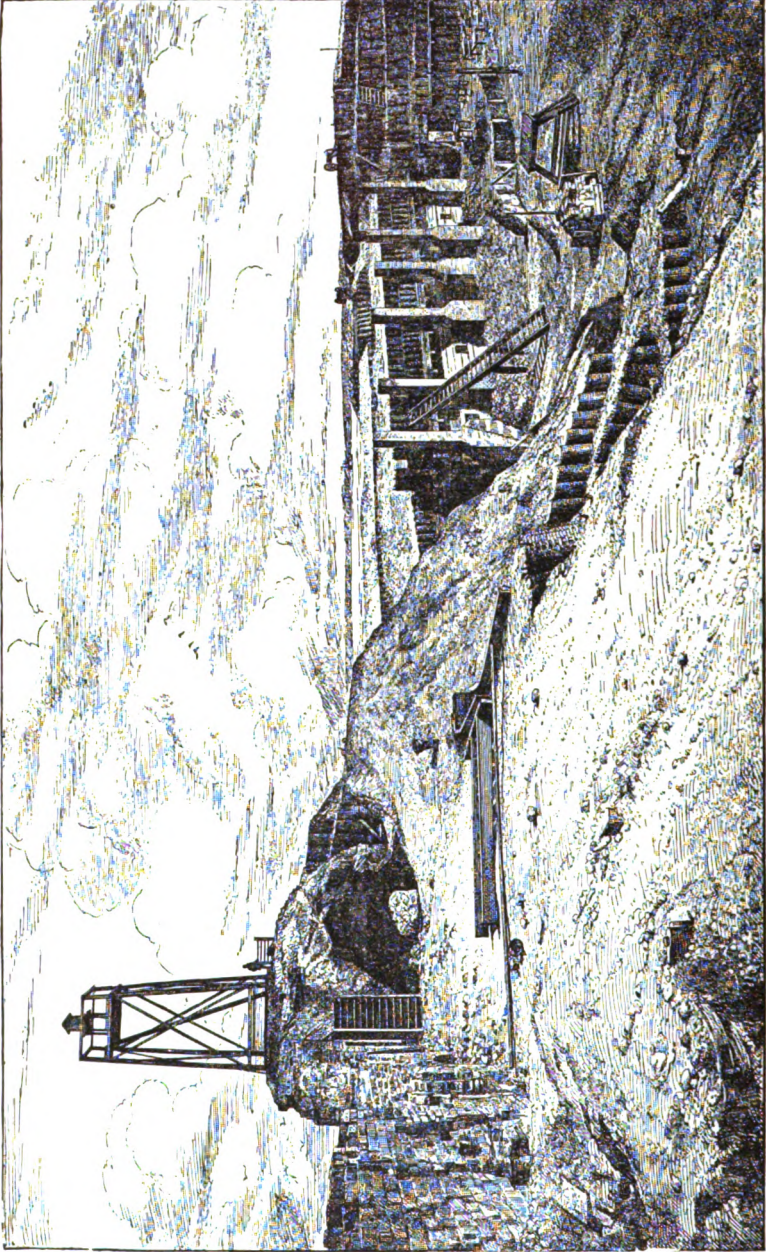

**FORT SUMTER : Interior View of the Sea-face and Eastern Angle.**  
(Taken soon after the evacuation of the fort.)

made by night with secrecy and despatch, with the noise of great guns firing heavily, for the Union batteries had opened a severe fire upon Sullivan's and James Islands, though not upon Fort Sumter, and with foreboding of disaster. But there were two features of unlikeness in the case. Public property was either destroyed or sought to be destroyed at Wagner, but by orders Fort Sumter was to be left intact. At Battery Wagner the fury of its last bombardment had torn and rent its military lines, had ploughed and tumbled all the slopes and parapets, had filled its ditch and strewed its parade with wrecks of ruin. At Fort Sumter ruin had wellnigh been covered up and concealed; trim ranks of gabions held up the slopes of sand or débris; capacious and comfortable quarters sheltered in perfect safety the garrison; the parade even looked swept and garnished; the casemates, either armed or turned to useful purposes, still recalled the old brick fort; the crest of the walls showed some lines of regularity; and over all dominated the bombproof covering of the stair-tower at the south-western angle, with not one inch lost from the original level of the fort at that point, forty feet above high-water mark.

The eye of the commander took in all these things for the last time as he went the rounds with his two attendant officers, pacing the deserted chambers, which only echoed to his footfall, or walking through the deep shadows of the long gallery, until he emerged at length through the sally-port upon the open wharf, where the boats were waiting for him. Then nothing remained but to cast off the lines, which was done by himself, assisted by Lieutenants White and Swinton, and to step on board. Fort Sumter loomed grandly before their lingering eyes for a few minutes longer, then the dark night enveloped it and they saw it no more.

Early the next morning it became known that the city had been evacuated, and it was soon occupied by the Union troops. Two hundred and fifty cannon fell into the hands of the captors, who had been engaged in active operations for upward of five hundred and sixty-seven days before the best-defended city of the Southern coast.



## CHAPTER XIV.

### RÉSUMÉ AND CONCLUSION.

To estimate rightly the place occupied in the war between the States by Charleston harbor and Fort Sumter, its once conspicuous citadel, the following considerations should be borne in mind :

(1.) The earnest spirit of the Southern States was not the echo of some ambitious politicians, as so often falsely represented, but the rising of a people who could judge for themselves and believed themselves wronged. Their resistance when it was made, and their stubborn defense when that was all they could offer, were proofs that no frantic ebullition of sectionalism had been excited by "fire-eating" agitators, but that a long-existing, constitutional difference was at issue ; and the spirit of the people was in keeping with the gravity of the situation. Although South Carolina was ever grateful for the friendship and support of her sisters of the Confederacy throughout the war, she was held by the North to be specially responsible for its outbreak. The scene of the outbreak was Charleston harbor, and the very focus of its intense feeling was precisely there, at Fort Sumter. This lent its particular animosity to the Union mind, and indirectly gave to the people of the Palmetto State an impulse and an energy which served to protect their seaport to the last, but went beyond their military strength in men and means of defense.

(2.) The disparity in fighting population and in materials of war between the combatants was very great. The large part of the laboring class in the South was not to bear arms in this contest, and there were no large cities to furnish that floating, adventurous population which the North could always draw

upon to recruit her armies.<sup>1</sup> With ports well watched by blockading squadrons, the South was forced to establish industries altogether strange to her people. True, there was good foundry-work done in Virginia and North Carolina, and a superior powder-mill at Augusta, Georgia, but South Carolina, in particular, was more agricultural than most of the other States. Artificers, skilled workmen in metals and machinery, were very scarce in her borders and had to be brought from other States. Yet there was no lack of effort to do the best under the circumstances. At the very opening of the war in Charleston harbor iron was used to protect water-batteries; armored gunboats were built at Charleston as at other places; cannon were rifled and banded there;<sup>2</sup> all manner of projectiles prepared; and the daring feat of recovering the guns out of the wreck of the *Keokuk* should prove that extraordinary difficulties of a mechanical kind presented themselves, and were in large measure overcome.

(3.) The conduct of the war in front of Charleston was most particularly marked by the new era of heavy rifled breaching-guns and iron-clad squadrons. The world looked on and wondered. Both by land and by sea the fortifications of Charleston were subjected to unprecedented trial. New demands were made upon its engineers and artillerists to increase the offensive and defensive powers of sea-coast warfare. They could not make guns to compare with Parrott's 200- and 300-pounder rifles, but they could excel in practice with their 10-inch columbiad smoothbores and 7-inch Brooke rifles. The engineers around Charleston, as well as Wilmington and Savannah, soon learned how to fight the enemy with sand, as General Beau-

<sup>1</sup> One of the Union regiments on Morris Island, having been reduced, was recruited at the North with 289 conscripts and substitutes; for the latter the sum of \$8000 was paid in Philadelphia. (W. W. H. DAVIS.)

<sup>2</sup> Four armored gunboats were built between 1862 and 1865—viz. the *Palmetto State*, the *Chicora*, the *Charleston*, and the *Columbia*, but the last was disabled by accident after completion and never used.

Cannon were rifled and banded, and projectiles of all kinds made in great quantities, from the summer of 1861 to the end of the war, at the machine-shops of J. M. Eason & Brother, of W. S. Henery, and of the Confederate States arsenal in Charleston.

## CHAPTER XIV.

### RÉSUMÉ AND CONCLUSIONS.

To estimate rightly the place occupied in the war between the States by Charleston harbor and Fort Sumter, its once conspicuous citadel, the following considerations should be borne in mind :

(1.) The earnest spirit of the Southern States was not the echo of some ambitious politicians, as so often falsely represented, but the rising of a people who could judge for themselves and believed themselves wronged. Their resistance when it was made, and their stubborn defense when that was all they could offer, were proofs that no frantic ebullition of sectionalism had been excited by "fire-eating" agitators, but that a long-existing, constitutional difference was at issue; and the spirit of the people was in keeping with the gravity of the situation. Although South Carolina was ever grateful for the friendship and support of her sisters of the Confederacy throughout the war, she was held by the North to be specially responsible for its outbreak. The scene of the outbreak was Charleston harbor, and the very focus of its intense feeling was precisely there, at Fort Sumter. This lent its particular animosity to the Union mind, and indirectly gave to the people of the Palmetto State an impulse and an energy which served to protect their seaport to the last, but went beyond their military strength in men and means of defense.

(2.) The disparity in fighting population and in materials of war between the combatants was very great. The large part of the laboring class in the South was not to bear arms in this contest, and there were no large cities to furnish recruiting, adventurous populations.

3-1 3-1 3-1

3-1 3-1 3-1

3-1 3-1 3-1

3-1 3-1 3-1

3-1 3-1 3-1

upon to recruit her armies.<sup>1</sup> With ports well visited by the raiding squadrons, the South was forced to establish industries altogether strange to her people. True, there was good iron-work done in Virginia and North Carolina and a famous powder-mill at Augusta, Georgia, but South Carolina, in particular, was more agricultural than most of the other States. Artificers, skilled workmen in metals and mechanics, were scarce in her borders and had to be brought from other States. Yet there was no lack of effort to do the best under the circumstances. At the very opening of the war in Charleston iron was used to protect water-batteries; armored gunboats were built at Charleston as at other places; cannon were rifled and banded there;<sup>2</sup> all manner of projectiles prepared; and the daring feat of recovering the guns out of the wreck of the Keokuk should prove that extraordinary difficulties of a mechanical kind presented themselves, and were in large measure overcome.

(3.) The conduct of the war in front of Charleston was not particularly marked by the new era of heavy rifled breeching-guns and iron-clad squadrons. The world looked on and wondered. Both by land and by sea the fortifications of Charleston were subjected to unprecedented trial. New demands were made upon its engineers and artillerymen to increase the offensive and defensive powers of sea-coast warfare. They could not make guns to compare with Parrot's 20- and 24-pound rifles, but they could excel in practice with the best columbiad smoothbores and 3-inch Howitzers. The engineers around Charleston, as well as Wilmington and other places, soon learned how to fight the enemy with advantage.

<sup>1</sup> One of the Union regiments at Fort Mifflin was recruited at the North with 200 men, and the sum of \$8000 was paid in Philadelphia.

<sup>2</sup> Four armored gunboats were built at Charleston, S. C., in the same State, the *Chiron*, the *Catfish*, the *Keokuk*, and the *Keokuk*, disabled by accident after the capture of the city.

Cannon were rifled and banded there in quantities from the shops of J. W. ... On the States ...

regard well expressed it, building works of such strength—and, when time permitted, of such finish—as had not previously been seen anywhere. To protect themselves against the engines of war and the armored vessels of the new era the Confederates were obliged to make a new era themselves, and that chiefly in the matter of harbor obstruction and torpedo defense. How effective these last were found has been fully shown in this history of operations. The iron-clad squadrons of Rear-Admirals DuPont and Dahlgren were as effectually stopped for more than two years by fear of these as by anything else.<sup>1</sup>

In writing upon "Submarine Mining" an able contributor to *Harper's Weekly*, September 29, 1888, refers as follows to the first successful applications of the science ever made:

"To the dread of such a foe, though he disguised himself in tinker's pots and pans and similar grotesque ironmongery, must be credited the frequent dilatory action of our navy during the 'late unpleasantness.' In the museum at Willett's Point may be seen numerous specimens of the submarine armory of our late Confederate foes. Wood and metal were used as most convenient. But queer forms, crude appliances, and a science as yet in its babyhood were made terrible by the skill and energy of their engineers. Some forty of our war-vessels were destroyed or put *hors de combat* by this torpedo 'prentice-work. It was the one instrumentality which crippled and minimized our naval supremacy."

There are many who will always believe that if a gun had not been fired by the forts on the 7th of April, 1863, the whole squadron of DuPont would have turned back from the rope-obstructions in the channel with the same alacrity as was shown by the leading vessel Weehawken on that occasion. She was armed with a special raft for her protection, while none of the

<sup>1</sup> Rear-Admiral Goldsborough's opinion of iron-clads, Washington City, February 26, 1864:

"The protection of harbors now-a-days does not lie in forts. They for this particular purpose are immeasurably effete, or at most but of subsidiary importance. It lies essentially in powerful steam-rams, aided, when necessary, by obstructions in passage-ways. Is it the forts of Charleston, I would ask, that now secure the place from capture? Certainly not. They alone, or any other forts alone (by which I mean in the absence of rams and obstructions), can be passed by fast and powerful vessels with impunity, assuming of course that there is water enough to float them."—(Exec. Doc., *Armored Vessels*, page 576.)

other vessels were so furnished. The Union navy appears to have not even taken steps to examine seriously the obstructions with small boats by night until the very close of the war. (*Memoir of Dahlgren*, page 492, and Appendix of this work, Chap. III.)

(4.) The defects of original construction in Fort Sumter were, in some particulars, very serious. As a general thing, the brick masonry was the finest of the kind, and the dimensions of the work were all that military science in those days required. But an exception was in the region of the magazines. These were in pairs (upper and lower) at the eastern and western angles of the gorge, and they were not originally protected on the interior or parade quarter of the fort as they should have been. A fire of shells from the fleet lying off the eastern angle of the fort could take the western magazine in reverse, finding weak places in the inner wall, at the ventilators, and particularly in the covering of the lower magazine. Much heavy work in stone, brick, and sandbags was required to protect the magazines in other respects and in consideration of the new era; but the defects above referred to attached to their original construction and added greatly to the labor of defense.

(5.) The means devised for strengthening Fort Sumter against improved artillery were simple, but they involved prodigious labor and constant vigilance. And it was to the completion of these *before the bombardments began* that the fort owed its stability. While the average force employed by the engineers may not have exceeded one hundred laborers, with about twenty mechanics, there were weeks and months when the force was raised to three hundred and fifty, and immediately before the first bombardment it numbered four hundred and fifty laborers and mechanics. At that period of preparation the work was carried on day and night; at later periods of repair, only in the night or only in the day. The upper and lower casemates of the sea-face, together with the upper and lower rooms of the gorge, were entirely filled, the casemates with sand alone, the rooms with wet cotton-bales laid in sand; while the magazines and the ramparts called respectively for the same laborious work. On the ramparts of the sea-face especially massive traverses and mer-

lons were constructed with sand brought in bags on the shoulders up the spiral stairs, fully thirty-five feet above the level of the parade. On the exterior of the gorge much heavy work of the same kind was done. When the period of incessant repairing of damages set in, the sand of the parade had been exhausted to a depth of four feet, and new material was required. This depended on smooth water, good weather, and the limits of harbor transportation, which were very serious drawbacks. Oftentimes, the only material for repair was the wet sand washed up around the base of the fort's walls and gathered under heavy fire with frequent casualties. The fiction of Fort Sumter's being protected by the spontaneous or fortuitous piling of its own débris has been pointed out and corrected in these pages. (See page 134.) Foresight contrived and hard work executed the plans of defense. If to any one precaution more than another the fort may be said to have owed its preservation, it was to the timely filling of the rooms of the gorge.<sup>1</sup> This gave an indestructible backing to the débris which fell and lodged without, but which was yet constantly disturbed and largely wasted by the enemy's fire, the rain and winds, and the action of the waves. The gorge, thus strengthened and maintained by frequent additions of fresh material, was the one great, ruling protection of the fort against the breaching-batteries of Morris Island.<sup>2</sup> Against assault the obstructions nightly placed on the exterior slopes and regularly taken in before daybreak have been described. Casualties were constantly occurring in the performance of this especial service. A boom of logs was maintained off the south-eastern angle of the fort.

(6.) The severity and duration of the bombardments, three principal and eight minor, must be remembered. Records of the firing may be found in the Appendix. Based on these and an estimate made by General Beauregard (*Military Operations*, vol. ii. page 127), the total weight of metal (land and naval fire)

<sup>1</sup> Seventeen rooms, eighteen feet six inches square: eight were eleven feet and nine were fourteen feet high—a labor of three weeks, night and day, for three hundred men.

<sup>2</sup> "The heap of rubbish at the gorge looks invincible." (*Memoir of Dahlgren, Diary*, October 27, 1863.)

thrown against Fort Sumter while defended by the Confederates must have been in the neighborhood of thirty-five hundred tons. If from this total the average percentage of missing projectiles be deducted, the remainder, twenty-four hundred tons, will represent the weight of metal striking the fort. The destructiveness of the fire may be measured by a few facts. When Rear-Admiral DuPont attacked, two shells, XV- and XI-inch, passed entirely through the weakest part of the scarp-wall, each by its own penetration, and burst in the interior of the fort. During Major-General Gillmore's first bombardment, after the demolition of the brick fort was technically accomplished, the effect of one heavy rifle-shell, on the 30th of August, was to bring down, "at one fall, four rampart arches on the north-east front, with terreplein, platforms, and guns." Later, the wall and casemates along the entire sea-face were battered down to the lower embrasures, about five feet above tide, although a backing of sand remained in the shape of a parapet, with a thin crest in places only fifteen or twenty feet high. The duration of the three principal and eight minor bombardments was altogether one hundred and fifty-seven days and one hundred and sixteen nights. But for a period of one hundred and twenty-three additional days and nights the fort may be said to have been under fire, though it was irregular. A determined and often destructive fire would be opened upon the wharf after dark, when it was suspected that the boats were arriving from the city; so hazardous was the communication. The total length of time that Fort Sumter was actually under fire between the 7th of April, 1863, and the 17th of February, 1865, when it was evacuated, was two hundred and eighty days, there having been three months in 1863 and two in 1865 when there was no firing upon the fort. The casualties in all that time were 319. Deduct the casualties of the accident when the magazine was exploded on the 11th of December, 1863, and the total, reduced to 267, appears very moderate indeed, considering the period of time, the weight of metal thrown, and the sometimes crowded state of the fort. The troops of the garrison proper were kept mostly in quarters, but suffered occasionally there, and constantly when exposed on guard-duty at night. The working force of the en-



gineers, consisting of negroes and a gang of white mechanics who were detailed soldiers, was exposed, repairing damages under fire, more constantly than the garrison, and it suffered in proportion.

(7.) The merits and demerits of the attack should be summarized, as should be also those of the defense. The merits of the attack will vary considerably as viewed from Fort Sumter in the one case, and from Charleston harbor in the other. They will vary, again, as regarded from the land or water, the part taken by the army or the navy. It is difficult to treat this topic briefly. Let it suffice that Major-General Gillmore must have had for his object in the descent on Morris Island either the capture of Fort Sumter alone or of the fort with the harbor and city together. Giving him full credit for demolishing the fort in one week's bombardment, the question remains, Why were 2400 men killed and wounded from his command on Morris Island without any military necessity at all, so far as Sumter was concerned? His main loss was in connection with Battery Wagner, a work practically of no value to Fort Sumter after breaching-batteries were established by him capable of demolishing Fort Sumter over the head of Wagner—the citadel over the head of the advanced work—as they readily did a fortnight before the evacuation of Wagner. Nor could that sacrifice of men be explained by any advantage to be gained with regard to the city and harbor. The siege of Wagner and the demolition of Fort Sumter had their little circumscribed theatre of war on Morris Island, a *cul-de-sac*, within which the Union troops shut themselves, and into which a superior strategy would never have taken them except for diversion. There was skill of the highest kind exhibited in the breaching of Fort Sumter and in the slow siege of Battery Wagner, but it had as little to do with the capture of Sumter and Charleston as the blackboard demonstration of a problem by a cadet at West Point.

Nor had it anything to do with the effectiveness of the blockade, as is advanced by General Gillmore (*Operations*, note on page 66), but inconsistently so, by his own admission that prior to the evacuation of Fort Wagner the ships of the fleet could pass and repass that fort without any serious molestation by

day, and could certainly station themselves along the whole channel by night. (*Operations*, note on page 65. "A glance at the chart will show." See also pages 42, 43.) Nor "to save valuable time" (page 43), inasmuch as the sites of these breaching-batteries had been two weeks in possession of the Union force before the general determined to use them. Had ground been broken there on July 11th, the day after the descent on Morris Island, the demolition of Sumter would have been accomplished two weeks earlier than it was.

Much nearer to a solution came the well-aimed but badly-executed attack by Major-General Foster on Fort Johnson in the following year.

The neglect of both the army and the navy commanders to stop the communication between Cumming's Point and Charleston was something graver than an oversight; it was a perpetuated blunder. The thing could have been done: its possibility was almost demonstrated by the general, and it could have been easily made practicable by the rear-admiral. The former saw its importance and frequently urged it upon the latter, but it was never done. (Appendix, page xcii). The immense advantages possessed by the Union fleet over the naval force and transportation of the harbor could have been turned to account one week after the descent on Morris Island, and its Confederate garrison could have been starved into capitulation. Two flotillas, one worked every night from Vincent's Creek, the other from the fleet lying off Morris Island co-operating with it, could have settled the possession of Cumming's Point without the bloody repulses before Wagner, without the long delay of the siege, and with the éclat of a captured garrison.

The naval operations before Charleston were of the highest value to those conducted by land. General Gillmore, while fighting his way on Morris Island, is found to be very often entirely dependent, by his own despatches, on Rear-Admiral Dahlgren for support, relief, and success. If estimated by the expenditure of ammunition, the greater part of the naval service was connected with the occupation of Morris Island by the army—a rather unprofitable undertaking. A small part only of its power was directed upon Fort Sumter and Sullivan's

Island. The firing of April 7, 1863, was at too long range to be a thorough test. The correspondence of Rear-Admiral DuPont with the Navy Department and of Rear-Admiral Dahlgren with Major-General Gillmore (to be found in the Appendix) will satisfy the reader that while the latter was continually under obligation to the former, better work and better fighting were done by the Union navy with inferior iron-clads on the rivers of the West than before the defenses of Charleston harbor. And yet so much more could have been done against Fort Sumter directly by the armored vessels coming in by night and wearing away its walls and the spirit of its garrison by slow persistent firing than was done on only two occasions, that General Beauregard has given it as his deliberate opinion that in this way alone the fort might at an early date have been destroyed and captured. (See note, Chapter IV., page 77.) This had nothing to do with passing into the inner harbor: the obstructions and torpedoes, it has been seen, deterred from that. It is apparent, under all the circumstances, that the Union navy was more distinguished for its co-operative service with the army before Charleston than for any achievement of its own in this quarter.<sup>1</sup>

(8.) The merits and demerits of the defense require perhaps a less partial witness than the writer. Nevertheless, it should be conceded that the artillery practice of the forts and batteries was equal to the finest ever known. Mr. Swinton, the historian, an eye-witness of the action of 7th of April, 1863, from his station on board the flagship has left his testimony (see page 61), and many naval officers have reported the same. The powder used in this action was of the superior quality manufactured by

<sup>1</sup> The effectiveness of the purely naval attack on the forts at Port Royal Entrance, South Carolina, in October, 1861, compared with the scant results before Charleston in the years which followed, can only be accounted for by the inferiority of the fortifications at Port Royal—guns crowded together *en barbette*, without traverses, according to old methods—and by the moral effect of obstructions at Charleston. The Confederate engineers learned, by costly experience at Port Royal and elsewhere in the first year of the war, how to build sea-coast batteries. Rear-Admiral DuPont brought to Charleston heavier guns and stronger vessels, by far, than he had taken to Port Royal. The Confederates had no heavier guns to oppose him, though they did have more of them, than at Port Royal, and chiefly within works of better construction.

Colonel G. W. Rains at the Augusta works, and it would have done better still with guns and missiles more nearly equal to those of the attack. Against XV-inch and XI-inch smoothbores and 8-inch and 10-inch rifles the Confederate artillerists could fight with nothing heavier than 10-inch smoothbores and 7-inch rifles. When all the risks of moving and shipping powder and loaded shells, sometimes necessarily under fire, and all the fatigues of the arduous service of the troops both at Battery Wagner and Fort Sumter, are considered; when the vigilance and readiness of the garrisons to repel assault are remembered; when the repulses which followed two assaults at Wagner, one at Sumter, and one at Gregg, are borne in mind; when the difficult but successful evacuation of Morris Island and the heavy naval attack on Sullivan's Island are fully estimated,—the qualities of Confederate officers and soldiery are seen to have been at their best in the defense of Charleston. The inventive genius also showed itself in the daring essays of torpedo-warfare; the patient and cunning labor of the spoilers of the wrecked Keokuk deserves all honor; the skill and nerve of those who dug out, threw down, and took away by night from Fort Sumter the heavy guns on which the defense of the city was again to depend, prove bold enterprise, if anywhere, to have been displayed around Charleston harbor; while, from the narrative as a whole, it must be concluded that the defense of Fort Sumter owed more to foresight and timely preparation than to any "burrowing in the ruins" after the ruins were made.

There appears to have been some neglect of opportunity at Battery Wagner when the mortars were so feebly plied from that post upon the besiegers (p. 154). Major-General Gillmore puts his finger upon this omission (*Operations*, pages 128, 129),<sup>1</sup> and complaint was made of it during the siege by two or three of the commanders of the fort. The scarcity of ammunition and the unsuccessful applications of the commanding general for the right kind of mortars (coehorns) have been given as reasons why the firing was not more vigorous.

<sup>1</sup> See General Beauregard's reply to General Gillmore in *North American Review*, July, 1886.

The loss of Morris Island may be charged among the demerits of the defense, since it so appeared to the Confederate Secretary of War and to Brigadier-General Ripley. But a fair examination of the statements made by General Beauregard and Brigadier-General Ripley will serve to explain, if not excuse, the loss. The enforced reduction of labor<sup>1</sup> and troops against General Beauregard's urgent appeals; his mature and scientific opinion as to the superior claim of James Island to be defended, if necessary, at the expense of Morris Island; and Brigadier-General Ripley's admissions in answer to his commander's categorical questions,—all taken together prove that some sacrifice was made necessary in the defense of Charleston harbor. The temporary demolition of Fort Sumter and the permanent evacuation of Morris Island were the sacrifices: as to the shelling of the city of Charleston, that was a game not paid for by the cannon expended in doing it. But while the Confederate sacrifice was one of position and ground, with no great loss, the Union sacrifice was conspicuously one of human lives, without any gain of position commensurate with that loss. (See further "The Strategic Value of Morris Island," Appendix E, and the chief engineer's report of January 14, 1864, Appendix F, page lxxiv.)

(9.) Three most critical periods in the defense of Fort Sumter deserve to be recalled:

(a) *The beginning of September, 1863*, when the fort was deprived of all offensive power as an artillery post, and the question of holding it or abandoning it was directly to be met. At this crisis nothing but the decision of General Beauregard, endorsing the opinion of Colonel Gilmer and Lieutenant-Colonel Harris, chief engineers, and opposing the opinion of other officers in the case, prolonged the defense of Fort Sumter.

(b) *The middle of December, 1863*, when the results of the explosion of the magazine and the burning out of the quarters,

<sup>1</sup> "The only labor available for the works on the south end of Morris Island was the details of soldiers from Colonel Graham's regiment—say of 100 to 150 men daily—which Captain Cheves reported were so steadily employed as to prejudice their drill and other camp duties." (*Colonel Harris, Chief Engineer's Report.*)

being the entire line of lower casemates on the western front, were so serious as to imperil the further holding of the fort. At this crisis nothing but the advantage of having no annoyance from the enemy's guns for two weeks saved the garrison from two evils that might have been fatal—viz. disease among those who could find some crowded shelter, and death among the remainder who could find no shelter at all.

(c) *The months of July and August, 1864*, when the fort was subjected to the third principal bombardment, the most prolonged of the three bombardments of that class. At this period the thin crest of the sea-front was worn away to its weakest condition. A direct fire upon it from the fleet, supplementing the slant fire from the batteries of Morris Island and steadily sustained for a week, would have uncovered the whole parade. But the actual damages of this long bombardment proceeded entirely from the land guns, and were inflicted upon other parts of the fort, where they were duly repaired. This left no time for repairing the sea-face, if that had been likewise damaged. It escaped injury by the oversight of the enemy, and in consequence the defense was prolonged.

(10.) A statement of the resistance and defense of Fort Sumter, as compared with other forts in the Confederate States and elsewhere, deserves to be considered :

PORT ROYAL, *South Carolina, November 7, 1861.*—Two earthwork forts, mounting 43 guns, among which were none heavier than two 10-inch and three 8-inch smoothbores, were silenced and evacuated after four hours' firing by the Union fleet of 17 sail, carrying about 200 guns, IX-, X-, XI-inch smoothbores, with some 15-, 20-, and 30-pounder Parrot rifles ; range during action, 800 to 600 yards.

FORT PULASKI, *Savannah River, Georgia, April 10-11, 1862.*—A casemated brick fort, of the same period as Fort Sumter and very like it, except in having only one tier of casemates ; garrisoned with 385 men ; armed with five 10-inch and nine 8-inch smoothbore columbiads, three 42-pounders, twenty 32-pounders, two 24-pounders (Blakely), and five mortars, making a total of 39 guns and 5 mortars. Union batteries on land, with average range of 1700 yards, mounting five

rifle cannon of James's make (84-, 64-, and 48-pounders), with five Parrott rifles (30-pounders), and ten columbiads of 8- and 10-inch; a total of 20 guns and 16 mortars. After a bombardment of a day and a half, total shots fired 5275, with a breaching cannonade of nine and a half hours, the fort surrendered, its magazine being in immediate danger. Previous breaching had been confined to 500, 700, and 1000 yards: this was done at 1700 yards.

**FORT McALLISTER**, *Ogeechee River, Georgia, March 3, 1863*.—This well-built earthwork, mounting eight guns, of which one 10-inch and one 8-inch, smoothbores, were the heaviest, was engaged for eight hours by three monitors carrying XV-inch, XI-inch (smoothbore), and 8-inch rifles (total six guns), firing about 200 rounds at range of 1400 to 1900 yards. The results were, one monitor's "deck badly injured" and 34 hits received. The fort suffered "no material damage nor any that could not be repaired in one night." One gun disabled.

**FORT SUMTER**, *Charleston Harbor, April 7, 1863–February 18, 1865*.—A casemated brick fort, mounting 80 guns, the heaviest being four 10-inch smoothbores, two 9-inch, eight 8-inch smoothbores, and two 7-inch rifles, garrisoned by 550 men, was attacked April 7, 1863, by iron-clad squadron of 9 vessels, carrying 32 guns, XV-, XI-inch smoothbore, and 8-inch rifles. Supported by other works, the fort repulsed the squadron in action of two and a half hours, disabling four and sinking one of the vessels. Only 37 guns of its armament were fired against 23 guns of the squadron, the fort firing 831 times, the vessels 139 times. The sea-wall of the fort was penetrated entirely in two places, but repaired with backing over night: other injuries slight. The attack was not renewed.

August 17–24, 1863, breaching-batteries on land, out of reach of the fort's guns, demolish, and by September 1st silence, it. The guns used for breaching were Parrott rifles, 100-, 200-, and 300-pounders, and did their work in one week at the unprecedented range of from 3400 to 4300 yards, firing percussion shells and bolts.

On September 8, 1863, the surrender of the fort was demanded

and refused. That night the fort repulsed a naval assault, taking 115 prisoners and four barges.

Subsequently, while enduring two greater and eight minor bombardments, and suffering the injuries of an exploded magazine with a disastrous burning of quarters, the fort was gradually transformed into a shapely and powerful earthwork, armed with five heavy guns in casemates and thoroughly protected against assault. It continued to be held until the whole coast was abandoned by the Confederates near the close of the war, and so it was never surrendered.

#### GENERAL SUMMARY, FORT SUMTER.

1863-1865.

Total number of projectiles fired against it . . . . .	46,053
Total weight in tons of metal thrown against it (estimate) . . . . .	3,500
Total number of days under greater bombardments . . . . .	117
Total number of days under minor bombardments . . . . .	40
Total number of days under fire, steady and desultory . . . . .	280
Total number of casualties (52 killed, 267 wounded) . . . . .	319

#### GENERAL SUMMARY, BATTERY WAGNER.

Total number of projectiles fired against it . . . . .	18,491
Total weight in tons of metal thrown against it (estimate) . . . . .	1,416
Duration of siege (days) . . . . .	58
Total number of casualties (July-September) . . . . .	318

This loss is not inclusive of that in the two assaults and the landing on Morris Island.

**FORT MORGAN, *Mobile Bay, Alabama, August 5-23, 1864.***—A large brick fort with a strong water-battery and some out-works, the whole armed with 47 guns, among which were eleven 10-inch and three 8-inch smoothbores, and eleven 8-, 6-, and 5-inch rifle cannon; garrison, 500 men (an armament much more powerful than Fort Sumter's). In the naval attack of August 5th, made by 4 monitors and 14 wooden ships, carrying 158 guns, XV-, XI-, and IX-inch smoothbores and 8- and 6-inch rifles, the fort fired 491 projectiles, being assisted by the iron-clad ram Tennessee and three wooden gunboats, carrying 12 heavy guns (7-inch and 6-inch rifles). The fleet forced the passage into the bay with some loss. On August 8th a summons



to surrender was received and refused. The Union army then combined with the navy, establishing land-batteries on the rear at short range (12 guns and 16 mortars), and the two forces bombarded the fort from all sides, day and night, for twenty-four hours, August 22d-23d. The walls were nearly breached. All heavy guns save two were disabled. The fort was set on fire twice and the garrison much exhausted, so that explosion of the magazine was threatened. Surrender was made on August 23d (the nineteenth day). The guns were protected by traverses, but there appears to have been scant bombproof protection for the garrison.

FORT FISHER, *Cape Fear Entrance, North Carolina, January 13-15, 1865.*—A fortification of sand, not an enclosed work, but of extensive trace and massive proportions. Of two principal fronts, that on the land side was 500 yards long and mounted 17 guns; that on the sea side was nearly 1500 yards long and mounted 20 guns. The latter were the heaviest, being eight 10-inch and four 8-inch smoothbores, one 10-inch rifle, three 8-inch, one 7-inch, and three 6-inch rifles. The Union fleet, numbering 55 vessels of war, among them being five iron-clads, *was the most powerful naval force ever assembled*, as it carried 600 guns of the heaviest calibre then in use. A division of the army accompanied it in transports for purposes of co-operation. At the end of two days' (about twenty-eight hours') bombardment the works were assaulted by two columns, one from the navy on the sea-face, the other from the army on the land-face. The former was repulsed; the latter after nearly five hours' hard fighting, much of it hand to hand and assisted by the heavy shelling from the fleet, was successful at ten o'clock on the night of January 15, 1865. The fire of such a fleet had the effect of driving the garrison finally under shelter of the bombproofs; but, though one-half of the guns had been rendered unserviceable, the works were pronounced of about the same strength as before the bombardment (report of Lieutenant-Colonel Comstock, U. S. Engineers); while the comment of the rear-admiral commanding, in his report to Washington, is here extracted: "I was in Fort Malakoff a few days after it surrendered to the French and English. The combined armies of the two nations

were many months capturing that stronghold, and it won't compare, either in size or strength, with Fort Fisher."

The brave defenders of Fort Fisher needed only a timely reinforcement of fresh troops to have repulsed the assault. They had reason to expect it, but it never came. They were commanded by Major-General W. H. C. Whiting, who had also directed the entire construction of the works. He died of wounds received in the defense. (The above account relates only to the second bombardment, the first, which was about three weeks before, having been a failure.)

From the annals of European wars the following notes are gathered in further illustration of the history of defense:

On October 17, 1854, the allied fleet off Sebastopol attacked the forts in two grand divisions, the French attacking the forts on the south side of the entrance to the harbor, the English those on the north. The two fleets were engaged four hours. The French fleet, carrying about 600 guns, but fighting one-half, was opposed by three Russian forts fighting, altogether, but 73 guns, at the long range of from 1600 to 1800 yards. The English fleet, carrying about 500 guns (none heavier than 68-pounders), engaged Russian forts and batteries fighting 80 guns, at from 800 to 1200 yards. Thus the allied guns, a total of 1100, advanced to attack 153 of the Russian guns, being nearly eight to one, but the result was that they did little or no harm to the forts as regards damaging casemates. Two of the English ships were disabled and two others heavily punished. Kinglake, the historian, writes: "If this was the heaviest sea-cannonade that up to that time had been known, it was also, in proportion to its greatness, the most harmless." The casualties of the Allies were four times as great as those of the Russians, and the result, altogether, was a discouragement for the former.

Although Fort Sumter could hardly be said to have been besieged, the defense of Strasburg in 1870 is of interest in relation to it. The siege lasted fifty days, the bombardment not more than thirty-one days. These figures correspond rather singularly with those of the siege of Fort Wagner on Morris Island.

The fortress was surrendered to the Germans September 27, 1870. The French loss was about 2800; the German, about 800. In the case of Fort Wagner the proportion was reversed; the besiegers lost upward of 2400, the besieged only 500 men. The German loss was but one-fiftieth of their entire force; the Union loss was nearly one-third of their entire force. The French loss was about one-sixth of their garrison; the Confederate loss was more than a third of theirs.

---

From a due consideration of the many facts which have been summarized under the foregoing heads, it is hoped that all minds will be enabled to form a true estimate of the Confederate defense of Charleston harbor. After all, the verdict of posterity will be the surest. It may not yet be full time for mature opinion, but already the passions of the combatants have cooled and their judgment of one another is becoming yearly more just and more generous. The North has impressed the South with respect for the national idea—a motive new and strange to the latter, but destined in the providence of God to lead both sections, united in one great people, to higher and grander achievements as the years roll on. In that period of national greatness it may happen that due credit will yet be given to the formative and conservative value of Southern principles, as old as the foundation of the Union itself.

The once Confederate States will never, for their part, let the record of Charleston harbor be lost from the volume of their common history, while South Carolina will surely be justified for the sentiments with which her children to remotest generations will regard the conduct of this defense. Through all the State's experiences, from colonial days to the present time, it may be seen that her difficulty has been made her opportunity. The story of this determined resistance will but emphasize the lesson. It did not end in triumph, but it has left behind a setting glory as of the western skies, a blazonry of heroism where gold and purple serve to tell of valor and endurance, and the crimson hue is emblem of self-sacrifice in a cause believed to be just.



# APPENDIX.

---

## APPENDIX A.

### CALENDAR OF EVENTS IN THE DEFENSE OF CHARLESTON, SOUTH CAROLINA.

1861.

- January 9. The transport-steamer *Star of the West*, carrying troops and stores to relieve the garrison of Fort Sumter, was stopped and turned back by the firing of a small battery on Morris Island, manned by the cadets of the South Carolina Military Academy, under command of Major P. F. Stevens.
- March 3. Brigadier-General G. T. Beauregard assumes command in Charleston.
- April 12-14. Bombardment of Fort Sumter, with surrender of the post by Major Robert Anderson, commanding, to the Confederate troops under Brigadier-General Beauregard.
- May 11. Blockade of harbor begun by steam-frigate *Niagara*.
- August 21. Brigadier-General R. S. Ripley assigned to command of Department of South Carolina.
- October 12. Messrs. Mason and Slidell run the blockade, escaping to Cuba.
- October 26. Confederate steamer *Nashville* escapes from the harbor.
- November 5. General R. E. Lee assigned to command Department of South Carolina, Georgia, and East Florida.
- November 7. Bombardment and capture of the forts at Port

- Royal Entrance by Union fleet of seventeen sail under Flag-Officer S. F. DuPont. Confederates, under Brigadier-General T. F. Drayton, effect retreat to the mainland.
- November 8. General Lee assumes command of department.
- November 16. Captain Duncan N. Ingraham assigned to duty as flag-officer naval forces in Charleston harbor.
- December 17. Capture of Confederate picket-guard (6) on Chisholm's Island, Coosaw River. Evacuation of Rockville, Wadmalaw Island.
- December 20. The first "Stone Fleet" sunk by the Federals on the bar of Charleston, off Maffitt's Channel.

## 1862.

- January 1. Engagements at Page's Point, Port Royal Ferry, Coosaw River, between land and naval forces.
- January 20. Second "Stone Fleet" sunk on Charleston bar.
- January 22-25. Expedition to Edisto Island under Colonel P. F. Stevens, Holcombe Legion.
- February 10. Skirmish on Barnwell Island.
- February 11. Edisto Island partly occupied by Union forces.
- March 3. General Lee called to Richmond, Va.
- March 14. Major-General J. C. Pemberton assumes command of the Confederate troops of the Department of South Carolina and Georgia.
- March 15. Major-General D. Hunter assigned to command of Union forces in Department of the South.
- March 19-24. Reconnoissance on May River, S. C.
- March 20-24. Operations near Bluffton, S. C.
- March 29. Affair on Edisto Island. Major F. G. Palmer of Holcombe Legion, with Major A. C. Garlington, captures 19 of the Union force.
- April 5. Complete occupation of Edisto Island by Union forces.
- April 14. Reconnoissance of Seabrook's Island by Union forces covered by a gunboat.
- April 19. Skirmish on Edisto Island.
- April 29. Engagements at Pineberry, Willtown, and White Point, between Union gunboats and land forces.
- May 5. Martial law proclaimed in Charleston.

- May 12. Disarmament of Cole's Island.
- May 13. Abduction of steamer Planter from the wharf at Charleston.
- May 20-21. Federal gunboats occupy the Stono above Cole's Island and Battery Island, shelling them, and capturing a picket-guard on the latter.
- May 25. Floating battery, Captain F. N. Bonneau, stationed near Dixon's Island, engaged and drove off a gunboat in Stono.
- May 26. Brigadier-General R. S. Ripley transferred to Virginia.
- May 29. Demonstration of Union troops, under Colonel B. C. Christ, being a full regiment, with artillery, on the Charleston and Savannah Railroad; met near Pocotaligo and prevented from striking the railroad by a small Confederate force (186 cavalry) under Colonel W. S. Walker, after a skirmish of two hours: Union loss, 11; Confederate, 9.
- June 2. Gunboat in Folly River shelled Legaré's Point and Secessionville, head-quarters of Brigadier-General S. R. Gist, commanding James Island. Fire returned by Confederate batteries. Enemy landed in force and drove in pickets from southern extremity of James Island. Union force under Brigadier-General I. I. Stevens.
- June 3. Skirmish at Sol. Legaré's place below Secessionville, James Island. Three guns of Confederate light battery mired and captured; 22 Union prisoners made by a charge under Lieutenant-Colonel E. Capers. The movement, a reconnoissance in force made by a brigade supported by gunboats in Stono, was thwarted.
- June 6. Brigadier-General William Duncan Smith assumed command of James Island.
- June 7. Skirmish on John's Island.
- June 8. Skirmish with rifle-pits in advance at Secessionville. Capture of a small Confederate picket. Union force retired under fire of field-gun and floating battery.
- June 10. Confederates reconnoitre in force on James Island, with loss to Forty-seventh Georgia volunteers of 60 to 70 men.

- June 14-15. Skirmishing continued. Fire also opened upon the post of Secessionville by a battery of Parrott guns in advance of the Union position. Brigadier-General N. G. Evans assumes command of James Island.
- June 16. Battle of Secessionville. Union troops under Brigadier-General H. W. Benham, commanding three divisions, to the number of 7000 men; one division assaulted the work, garrisoned by 750 men, under command of Colonel T. G. Lamar, and met with a disastrous repulse, losing nearly 700 men; Confederate loss, 204, of which 32 were in the advance movement under Brigadier-General Hagood.
- June 21. Engagement at Simmons's Bluff; two gunboats shell-ing rifle-pits and light battery (Marion).
- June 25-27. Union gunboats in South Santee; skirmish at Blake's place.
- July 4-7. Union troops evacuate James Island.
- August 19. Martial law in Charleston suspended.
- August 21. Boat-expedition under Captain Stephen Elliott of Beaufort Artillery and Captain J. H. Mickler, Eleventh South Carolina volunteers, captured a company of the Third New Hampshire regiment, picketing on Pinckney Island.
- September 24. Major-General Pemberton superseded by General Beauregard.
- September 30. Expedition of Union force against Bluffton.
- October 16. Brigadier-General R. S. Ripley resumes command of First Military District, South Carolina.
- October 22-23. Second action, Frampton Place, near Pocotaligo. A Union force of 4500 men, under Brigadier-General J. M. Brannan, supported by gunboats on the tributaries of Broad River, advanced with skirmishing from Mackay's Point toward Old Pocotaligo. Here they were met and driven back to their gunboats by Brigadier-General W. S. Walker. Union loss, 340; Confederate loss, 163. Near Coosawhatchie the railroad was struck by the enemy, but with trifling damage, and his force was pressed back by Colonel C. J. Colecock, commanding cavalry.

The iron-clad rams Palmetto State and Chicora were at

the end of this year completed and put on duty in Charleston harbor, each mounting four guns.

**1863.**

- January 30. Capture of Federal steamer Isaac Smith (eleven guns) in Stono River by combination of light artillery and infantry in ambush, but without parapets, on James and John's Islands, the expedition being under command of Lieutenant-Colonel Joseph A. Yates, First South Carolina Artillery. Prisoners, 11 officers and 108 men, among whom were 24 casualties.
- January 31. Attack before daylight on blockading squadron, off the Charleston bar, by Flag-Officer D. N. Ingraham, commanding the iron-clad gunboats Chicora and Palmetto State. Two of the blockaders were temporarily disabled—casualties 47—and surrendered, but afterward escaped in the darkness. The Union ships were driven off during several hours from four to five miles outside the bar, but no raising of the blockade occurred.
- February 1. Skirmish on Bull's Island between a small body of Confederate troops (50), commanded by Captain Charles T. Haskell, Jr., First South Carolina (regular) Infantry, and a force of twice the number from the blockading gunboat Flambeau.
- February 13. Three steamers with cotton run the blockade, and one enters from Nassau on this night.
- February 21. Gunboat Flambeau bearing flag of truce fired on from Fort Moultrie.
- February 25. Capture of a Confederate lieutenant and six men on the wreck of a blockade-runner at North Santee Entrance.
- March 7. Fortification of southern end of Morris Island begun by the Confederates.
- March 12. Dash across Skull Creek, Broad River, by Confederates, capturing an officer and some men of the Signal Corps.
- March 28. Occupation of Cole's and Folly Islands by Union forces under Major-General D. Hunter.



- April 7. Attack on Fort Sumter by Rear-Admiral DuPont, commanding the iron-clad squadron of nine vessels; engagement lasted two hours and thirty minutes, but five out of the eight vessels in action were disabled in from forty-five to sixty minutes; one sank next morning. The fort, with garrison of 550 men, commanded by Colonel Rhett, First South Carolina Artillery, was seriously damaged in a few places, but made ready to renew the fight next day. The casualties on both sides were slight: Union, 23; Confederate, 6.
- April 9. Destruction of the armed steamer George Washington in Coosaw River by Confederate light batteries.
- April 10–11. Night scouting-expedition to Folly Island, with capture of a picket by Confederates, the island under command of Brigadier-General I. Vogdes.
- April 27. Schooner burnt by Union expedition to Murray's Inlet.
- May 4. Expedition by Union gunboats to Murray's Inlet: Union casualties, 4.
- May 10. Unsuccessful expedition with Confederate spar-torpedo boats against monitors in North Edisto.
- May 31. Union reconnoissance of James Island by small land force, supported by gunboats in Stono.
- June 7–8. Night scouting-expedition to Long Island in front of Secessionville; Lieutenant Samuel Dibble, Twenty-fifth South Carolina volunteers, taken prisoner by the Union picket.
- June 11–12. The wreck of blockade-runner Ruby shelled by light guns on Folly Island; replied to by Captain J. C. Mitchel, commanding works at south end of Morris Island.
- June 12. Major-General Hunter relieved by Brigadier-General Gillmore in command of Department of the South.
- July 6. Rear-Admiral DuPont relieved of command of the South Atlantic Blockading Squadron by Rear-Admiral Dahlgren.
- July 8–9. Night scouting-expedition to Folly Island, from Morris Island, by Captain C. T. Haskell, discovering flo-tilla moored and ready for crossing.

- July 10. Demonstrations on James Island and the Charleston and Savannah Railroad. Descent on Morris Island by Union troops (3000) and capture of works at the southern end; four monitors assisting largely in the attack. Confederate loss, 294; Union, 106.
- July 11. Assault of Battery Wagner by Union troops under Brigadier-General Strong, met and repulsed by garrison under Colonel Graham. Confederate loss, 12; Union loss, 339. Four monitors engaged Wagner for several hours after the assault.
- July 13. Union working-parties on first parallel, 1350 yards, in front of Wagner, shelled by guns and mortars of Battery Gregg and Fort Sumter. Construction of flanking Confederate works begun on Shell Point, James Island (Battery Simkins).
- July 14-15. Colonel Graham relieved in command of Wagner by Brigadier-General Taliaferro. Sally from Battery Wagner under Major Rion, Seventh South Carolina battalion, driving the enemy's pickets out of their rifle-pits.
- July 15. Brigadier-General Hagood's reconnoissance of Union position on James Island.
- July 16. Confederates attack the enemy on James Island, obliging them to fall back to the cover of the gunboats in Stono: losses small. The Pawnee and Marblehead forced to change positions by well-placed field-guns.
- July 17. Union forces, land and naval, withdraw from Stono. All communication by daylight between Morris Island and Charleston intercepted henceforth by Union batteries firing upon Cumming's Point.
- July 18. Bombardment of Wagner by the combined forces, land and naval, from noon to dusk, with 42 siege- and field-guns and mortars, 6 iron-clads and 4 gunboats, carrying 46 guns more: in action about 70 guns, throwing heaviest weight of metal up to this date of operations: estimated firing, 14 shots per minute. Brigadier-General Gillmore moved three brigades forward to the assault of Wagner: the first and second, being engaged, were repulsed with loss of 1500 to 2000 men. Confederate loss by bombardment and assault

- was 174 killed and wounded. The garrison of Wagner (1000) commanded by Brigadier-General W. B. Taliaferro.
- July 19. Flag of truce sent to Wagner from the fleet declined.
- July 20. Combined fire upon Wagner resumed: its only 10-inch gun dismounted. Fort Sumter fired upon by long-range 30-pounder rifles from land-battery on Morris Island (3500 yards), a few shells doing no damage, but wounding a drummer-boy. This was the first fire received from Morris Island. Work of filling up the officers' quarters on gorge with wet cotton-bales laid in sand was begun to-day; also building of new wharf and cutting new sally-port on western front.
- July 21. Flag of truce from General Gillmore to Battery Wagner received by General Hagood, commanding, but interrupted by firing from the fleet; resumed on 22d; new works erected by General Gillmore.
- July 23. Brigadier-General Hagood relieved by Brigadier-General Taliaferro. Second parallel established—870 yards from Wagner.
- July 24. Six iron-clads and four gunboats combine fire with batteries five hours upon Wagner; interrupted by exchange of prisoners. Colonel Harris, chief engineer, reports Wagner not materially injured. Partial disarmament of Fort Sumter begins at this date, the fort firing slowly every day and night upon enemy's works in front of Wagner.
- July 25. Another monitor joins the squadron, making six monitors, together with the New Ironsides. Light Parrott rifles again fired upon Fort Sumter. The flanking batteries of James Island, together with sharpshooters in Wagner, annoy the Union working-parties on Morris Island.
- July 28-31. Heavy combined firing upon Wagner, the New Ironsides taking part; the batteries also firing at night; General Gillmore constructing works for heavy long-range Parrott rifles, intended to breach Fort Sumter; working force there, numbering 323, engaged night and day strengthening the fort.

- August 1-4. Wagner received a daily fire, chiefly naval, and maintained annoying fire of sharpshooters with Whitworth rifles and telescopic sights. Construction of the Marsh Battery, afterward known as "Swamp Angel," begun by General Gillmore. The besiegers reinforced by 3000 troops.
- August 4-8. Capture of picket in Vincent's Creek by Confederate navy and army boats. At Fort Sumter mortar platforms completed in the parade for night-firing on Morris Island; the filling of upper and lower rooms of gorge (total, seventeen) completed; construction of traverses and merlons on parapet of sea-face and gorge begun; also building up of sandbag work, to reinforce exterior of gorge, begun with material brought from the city. Wagner armed on sea-face with three heavy guns. Confederate steamer Juno, Lieutenant Phil. Porcher commanding, ran down and captured a launch with officer and 10 men off Fort Sumter (night 5th-6th).
- August 8-10. Third parallel opened—540 yards from Wagner; narrow front for operations increases difficulty. Calcium light used to discover Confederate communication at Cumming's Point.
- August 11. Before daylight Wagner, together with Sumter and the James Island batteries, opened so heavily on trenches as to stop entirely the working-parties for the first time in the siege. Heavy fire on Wagner during day. Calcium light again thrown on Cumming's Point prevented landing of supplies. The James Island lines ordered by General Beauregard to be abandoned in favor of an advanced line one half shorter, extending from Secessionville to Dill's house on the Stono (Battery Pringle).
- August 12. Fort Sumter received the first firing of heavy Parrott rifles, in practice to get the range, as they were mounted in the breaching-batteries of Morris Island. Effects on masonry in places very destructive. Small steamer Hibben, discharging at wharf, had her boiler exploded by a shell. Total firing, 18; total casualties, 11 wounded.

- August 13. Land and naval practice on Fort Sumter. Total firing, 30; total casualties, 1 killed, 2 wounded.
- August 14. Practice of breaching-batteries as before; 10 shots.
- August 16. Practice of breaching-batteries as before; 48 shots. Engineers' working-force of laborers and mechanics, 350 to 450, engaged day and night for six weeks, has converted the two faces of Fort Sumter nearest Morris Island into a compact, massive redan of sand, encased with brick, having a height of 40 feet and a general thickness of 25 feet, with a portion of the gorge 35 to 40 feet thick. Upward of twenty guns have been removed from the armament since July, leaving but thirty-eight for the present service of the fort. Garrison numbers 500 officers and men, under Colonel Alfred Rhett, commanding.
- August 17. First day of first great bombardment of Fort Sumter, first period. Total shots discharged at the fort from breaching-batteries (11 guns) and the fleet, 948; total casualties, 1 killed, 18 wounded. Firing suspended at nightfall or only desultory. Battery Wagner and Battery Gregg under fire also from the batteries (siege) and the fleet (7 iron-clads, 7 gunboats). Wagner fought the fleet with three guns for more than an hour. Fleet-Captain G. W. Rodgers killed on the Weehawken; Captain J. M. Wampler of the Engineers killed in Wagner.
- August 18. Second day, heavy firing (14 guns) continued on Fort Sumter; casualties, 3. Wagner received fire of 3 iron-clads and 5 gunboats, besides the siege-batteries; from the New Ironsides in these two days 805 shells discharged.
- August 19. Third day, 15 guns from breaching-batteries fired heavily on the fort; desultory firing during the night; casualties, 5. Approaches upon Wagner checked by sharpshooting from the "ridge" picket-line and by flanking batteries of James Island. The New Ironsides alone shelled Wagner this day.
- August 20. Fourth day for Sumter; three new guns, one being a 10-inch Parrott rifle (300-pounder), added to the breaching-batteries, made a total of 18 guns; range, from 3447 to 4290 yards. Casualties, 3 wounded. 25,000

pounds of powder removed by night. Wagner shelled by New Ironsides and four gunboats. The Marsh Battery, designed to fire upon the city at 7900 yards, completed to-day.

August 21. Fifth day for Sumter; more powder (9700 pounds) removed to-night; casualties, 6. General Gillmore demands the surrender of Fort Sumter, with the immediate evacuation of Morris Island. Some unavoidable delay occurring, fire was opened on the city from the Marsh Battery before daylight of the 22d. The "ridge" in front of Wagner was assaulted without success. Captain Robert Pringle killed at Wagner to-day.

August 22. Sixth day for Sumter; only four guns left in serviceable condition; main flagstaff falling, colors were flown from the crest of the gorge; a night-attack by five monitors, firing about 50 shells in the direction of the western magazine, was serious. The fort replied with two guns, firing six shots, being the last fired from its walls. The monitors drew a heavy fire on themselves from Fort Moultrie. The rear-admiral, desiring to "force the obstructions," "prepared" three or four times to do so, but never reached them. Casualties, 5 wounded.

August 23. Seventh day; the fort soon reduced to one gun (Keokuk's) in good condition and two guns partly serviceable. Work pressed to secure magazine from danger of another attack by monitors firing in reverse. Flagstaff twice shot away; more powder shipped; casualties, 6 wounded. The fort, breached and demolished by seven days' firing (total 5009 rounds), closed the first period of the first great bombardment.

August 24-26. Council of defense held by the chief engineers and colonel commanding. The second period opens with only one-fourth of the daily rate of firing hitherto received. General Gillmore urges upon the rear-admiral the scheme of cutting off communications from Morris Island by picket-boats off Cumming's Point. Second failure to carry the "ridge" in front of Wagner (25th).

August 27-29. Capture of "the ridge" and pickets of Morris

- Island by Union charge (26th). Three days of nearly suspended firing on Sumter.
- August 30. Heavy shelling on Fort Sumter from the breaching-batteries ; casualties, 5 ; damages caused by the 10-inch rifle (300-pounder) very severe. Recovery of guns by night from the ruins, and shipment to city by gang under Assistant Engineer J. Fraser Mathewes. This night transport-steamer Sumter, with troops, fired upon in mistake and sunk by Fort Moultrie.
- August 31. Fort Sumter received only 56 shots. Fort Moultrie engaged with four monitors for four hours, suffering no damage. Major-General J. F. Gilmer announced as second in command at Charleston.
- September 1. Mortar-firing on Wagner disables four guns. Fort Sumter suffers again from the heavy Parrotts, 382 shots, and in the night from the iron-clad squadron, 245 shots, crumbling the walls and threatening the magazine as before ; casualties, 4 ; the fort had not a gun to reply. This attack of the iron-clads ends the second period of the first great bombardment. The work of saving guns from the ruins and removing them to the inner harbor began on the night of August 27th, and proceeded regularly from this date forward.
- September 2. Desultory fire on Fort Sumter. The sap approaches within eighty yards of Wagner.
- September 3-4. Wagner under fire and returning it, assisted by Gregg and the James Island guns. On the night of the 4th-5th, Major Elliott relieved Colonel Rhett in command of Fort Sumter. Failure, same night, in plan to assault Cumming's Point (Battery Gregg).
- September 5. Slow fire from batteries and New Ironsides on Wagner. The assault on Battery Gregg, Cumming's Point, made and repulsed on the night of 5th-6th. Head of sap opposite the ditch of Wagner.
- September 6. New Ironsides with six monitors and all the siege-batteries combine in heavy bombardment of Wagner. Preparations made for both its assault and its evacuation. Confederate troops under Colonel L. M. Keitt, command-

- ing, withdrawn successfully from Morris Island between 9 P. M. (6th) and 2 A. M. (7th) after a siege of 58 days.
- September 7. Rear-Admiral Dahlgren demands surrender of Fort Sumter. Monitor Weehawken runs aground between Sumter and Cumming's Point. Other monitors engage Fort Moultrie.
- September 8. Preparations in the fleet all day to assault Sumter. The same going on ashore under General Gillmore. To cover the Weehawken, 5 monitors and the New Ironsides engage the forts and works of Sullivan's Island, firing very heavily for three hours, with no damage to the works, this being the severest action hitherto between armored vessels and fortifications.
- September 9, 1 A. M. The assault on Fort Sumter by two columns of boats from the fleet repulsed, with capture of 115 prisoners, four boats, and three colors : 6 killed, 19 wounded ; total, 124 ; Confederate loss, none. Flag of truce sent in from the fleet to Sumter and receiving the dead.
- September 9-27. Fort Sumter enjoys 19 days of perfect rest. On Morris Island the working-parties busily occupied turning the captured batteries upon the harbor and building others, all armed with heavy rifle cannon and mortars.
- September 13-14. Capture of a Union telegraph-party on the banks of the Combahee River.
- September 15. Explosion of a magazine at Battery Cheves, James Island ; a lieutenant and five men killed.
- September 28. The first minor bombardment of Sumter begins ; 100 shots fired and 1 man killed.
- October 3. Close of bombardment, lasting six days ; 560 shots. Batteries of James and Sullivan's Islands fire irregularly upon Morris Island.
- October 5-6. Lieutenant Glassell, of the Confederate Navy, attacks the New Ironsides with small torpedo-boat.
- October 14. Fort Sumter mounts three heavy guns in channel casemates on north-eastern front.
- October 20. Union boat-expedition to Murrell's Inlet. Union loss, 1 killed, 10 captured, by detachment from Twenty-first battalion of Georgia Cavalry under Lieutenant E. Kennedy.



- October 22. Rear-Admiral Dahlgren holds a council of war in regard to entering the harbor. Six senior captains oppose and four juniors favor the attempt, the admiral's views being sustained by the majority.
- October 26. The second great bombardment of Sumter, land and naval, opens to-day with 188 shots and 1 wounded; continued day and night with guns and mortars.
- October 27-28. Firing becomes heavier—625 and 679 shots per day.
- October 29-31. These three days the fort received the severest fire of any in its whole experience, amounting to 2961 rounds and attended with 33 casualties: of these, 13 killed by falling of ruins before daylight on the 31st. Flagstaff gallantly replaced under fire by Captain Carson, Twenty-fifth South Carolina volunteers, and four others assisting him, on the 29th. Replaced again by Graham, Hit, and Swain of Twelfth Georgia battalion on the 30th.
- November 1-2. 786 rounds, 1 wounded; 793 rounds, 1 killed.
- November 3. Four scouts from the fleet attempt to land by night at the south-eastern angle, and are fired on. 661 rounds, 7 wounded.
- November 6. Flagstaff replaced by Sergeant Currie and Corporal Montgomery of Twenty-fifth South Carolina volunteers. Casualties, 2 killed, 12 wounded, all of Twenty-seventh Georgia.
- November 6-7. Confederate raid on Bull Island, Port Royal; the Union dock burned.
- November 7-10. Fort received 1753 rounds; 9 men wounded.
- November 11. 219; 1 wounded. Flag replaced by Sergeant G. H. Mays and Private Robert Antry, Twenty-eighth Georgia volunteers.
- November 12-15. 2326; 2 killed, 5 wounded.
- November 15. Demonstration of Union troops on John's Island met by Major Jenkins with artillery.
- November 16. 602; monitor Lehigh, aground under fire, much damaged by Confederate batteries before getting off.
- November 17-18. 959; 1 killed.
- November 19. 694; 1 wounded. Boats from the army (200

- men) attempt assault on Sumter, but, being discovered before landing and fired on, withdraw on night of 19th-20th.
- November 20. 1344; 3 killed, 11 wounded.
- November 24. 270. 3 killed, 2 wounded. Death of Captain F. H. Harleston at Fort Sumter. Skirmish near Cunningham's Bluff, South Carolina.
- November 25-26. 517.
- November 27. 380. Flag replaced by Privates James Tupper, Foster, Buckheister, and Bluett of Charleston battalion.
- November 28-Dec. 4. 1307; 1 killed, 1 wounded.
- December 5. 61. Last day of second great bombardment (41 days and nights). Third expedition to Murrell's Inlet. Union boat-party, 3 officers and 12 seamen, captured by two companies of Georgia cavalry (Twenty-first battalion) under Captain Harrison.
- December 6. Monitor Weehawken foundered at her anchorage off Morris Island.
- December 11. Explosion of magazine, with destructive fire; 11 killed, 41 wounded. Fort received 220 rounds, this being the second minor bombardment.
- December 12-31. No firing upon the fort. The garrison much tried by labor and hardships of crowded quarters.
- December 25. Attack by field- and siege-guns on gunboats in Stono. The Marblehead much cut up by Confederate fire, but escaped with loss of 3 killed and 4 wounded.
- December 28. Confederate works abandoned near Legareville, John's Island, and two 8-inch siege-guns carried off by expedition from gunboats.

## 1864.

- January 1-28. Desultory firing (8 days) on Fort Sumter.
- January 7. Affair on Waccamaw Neck; capture of a naval party of 25 by a lieutenant and a private of the Twenty-first Georgia Cavalry battalion.
- January 30. Flag replaced under fire by Acting Adjutant B. Middleton, together with Shafer, Banks, and Brassingham of Lucas's battalion (Fort Sumter).

- January 29–31. Third minor bombardment (583 rounds) begins and ends. New Confederate iron-clad Charleston added to defense.
- February 1–29. Desultory firing (16 days) on Fort Sumter.
- February 9–11. Union reconnoissance in force (2000) on John's Island met by Major Jenkins with 150 men, and afterward with larger force (2000) under Brigadier-General H. A. Wise; after skirmishing for two days the Union troops withdrew in haste to their boats. Confederate loss, 17; Union, 34.
- February 12. Western casemates, Fort Sumter, armed with 3 heavy guns.
- February 17–18. Destruction of gunboat Housatonic, off Charleston bar, by Lieutenant George E. Dixon, Company E, Twenty-first Alabama volunteers, who with his crew and torpedo-boat also perished.
- February 26–27. Capture of Union boat, with officer and 5 men, by Confederate navy-picket, off Fort Sumter.
- March 1–31. Desultory firing (10 days) on Fort Sumter.
- March 6. United States steamer Memphis attacked by a torpedo-boat in North Edisto River; a failure.
- March 14. Fourth minor bombardment (143 rounds). 5 wounded.
- April 1–28. Desultory firing (12 days) on Fort Sumter.
- April 3–6. Brisk mortar-shelling of fort's wharf at night.
- April 8–9. Demonstration of barges by night upon eastern shore of James Island; no action.
- April 14. Night-firing of Fort Moultrie on United States tug Geranium.
- April 20. General Beauregard relieved by Major-General Sam. Jones.
- April 28–May 4. Fifth minor bombardment (Fort Sumter), 7 days, 510 rounds.
- May 1. Major-General Gillmore relieved by Brigadier-General Hatch.
- May 4. Lieutenant-Colonel Elliott, commanding Fort Sumter, relieved by Captain J. C. Mitchel.
- May 10–12. Second council held by Rear-Admiral Dahlgren.

- The question of attacking Sumter negatived by seven out of nine.
- May 13. A Confederate picket (5 men) captured at southern end of James Island.
- May 13-16. Sixth minor bombardment (Fort Sumter), 4 days, 1140 rounds; casualties, 5.
- May 19-20. Boats discovered reconnoitring off south-western angle, and fired on from Fort Sumter with field-howitzer on parapet.
- May 26. Major-General Foster assumes command of Union forces in the department. Demonstration of gunboats up the Ashepoo and South Edisto Rivers. Union steamer Boston grounding in Ashepoo, near Chapman's Fort, and being shelled by Earle's light battery, was set on fire by the enemy and destroyed, with 60 horses.
- May 30-June 5. Seventh minor bombardment (Fort Sumter), 8 days, 319 rounds; 4 casualties.
- June 6. The New Ironsides left station for the North.
- June 7. Confederate transport-steamer Etiwan grounded off Fort Johnson, and destroyed by enemy's fire from Morris Island.
- June 6-30. Desultory firing (17 days) on Fort Sumter, attended by 2 casualties.
- June 20. The flag-staff of Fort Sumter gallantly replaced under brisk fire by Lieutenant C. H. Claiborne, assisted by Sergeant N. Devereux and Corporal B. Brannon of the Engineers.
- June 24. Flag replaced under fire.
- June 26. Flag replaced under fire by Privates Walter Steele and D. E. Badger.
- June 27. Flag replaced under fire. Preparations in Union army and fleet for striking another blow on Charleston.
- July 2. Brigadier-General Schimmelfennig lands a column on James Island; advancing by Rivers's Causeway, it was checked by Confederates, who lost two guns, but fell back to stronger position.
- July 3. Fort Johnson and its advanced work, Battery Simkins, assaulted at daylight of 3d by an expedition in barges from

- Morris Island, nearly a thousand strong. Feebly supported, the assault failed, and 140 prisoners, including the commander, Colonel Hoyt, and five officers, were taken. The Confederates were commanded by Lieutenant-Colonel J. A. Yates, First South Carolina (regular) Artillery.
- July 3-5. John's Island invaded by converging columns (5000 strong), and occupied, after stubborn resistance of small force under Majors Jenkins and Wayne, supported by Parker's Light Battery. Union troops on James Island driven back to the Stono, where monitors and gunboats cover them and shell the Confederate works very heavily.
- July 7-9. After two days' skirmishing at Grimball's Waterloo Place, the Union intrenched position on John's Island was attacked and carried by Confederate troops under Brigadier-General Robertson; and that night the Union force left John's Island, and the squadron withdrew from the Stono next day. In these operations, July 2d-11th, Union loss reported, 330; Confederate, 163, only 17 having been killed.
- July 7-8. Fort Sumter's third great bombardment begins. Flag shot away four times on 7th, twice on 8th; 784 rounds.
- July 20. The commander, Captain J. C. Mitchel, mortally wounded. Up to this (14th day) 29 casualties; 4890 rounds. In this first period the fort much damaged; the boom off the sea-face cut away; boats sunk at the wharf, etc. Captain Mitchel succeeded by Captain T. A. Huguenin same night.
- July 21. General Foster's powder-raft, to be exploded near the fort, was prepared for service, but not taken up as intended for this night.
- July 27-28. Captain Johnson, engineer in charge of Fort Sumter, severely wounded (twenty-second day), and succeeded by Lieutenant E. J. White.
- August 3. Flag of truce, exchanging 50 Union and Confederate officers, in the channel off Fort Sumter.
- August 4-23. Firing on Sumter continual, but slackened. Rear-Admiral Dahlgren lends General Foster guns from

- the fleet to supply the batteries on Morris Island, weakened by expenditure of many heavy rifle cannon.
- August 28. General Foster's powder-raft exploded harmlessly off south-western angle of Fort Sumter.
- September 1. Another attempt of the same kind failed.
- September 3. Flag exchange of surgeons and chaplains off the harbor.
- September 4. End of third great bombardment: 60 days; total, 81 casualties; 14,666 rounds fired at the fort.
- September 6-18. Eighth minor bombardment (the last), 9 days; 7 casualties; 573 rounds.
- September 19-30. Desultory firing, often brisk, on the fort, 6 days; 200 rounds.
- October 1-31. Desultory, at times brisk, firing on the fort, 18 days; 494 rounds.
- November 1-30. Desultory, at times brisk, firing on the fort, 13 days; 221 rounds.
- November 7. Blockading gunboat Pontiac receives a rifle-shell from Battery Marshall, Sullivan's Island, killing 5, wounding 7.
- November 30. Battle of Honey Hill, near Grahamville, C. and S. Railroad. Union repulse with loss of 754 men, Major-General G. W. Smith commanding Confederates, Brigadier-General J. P. Hatch commanding the Union force, 5000 strong. Confederate loss, 4 killed, 40 wounded.
- December 1-30. Fort Sumter received only seven shots one day this month.
- December 6-9. Brisk engagements near Coosawhatchie to break C. and S. Railroad; failed to do so.
- December 7-17. Truce, with exchanges, off the harbor.
- December 20. City of Savannah evacuated by Confederate forces under Lieutenant-General Hardee.
- December 31. Two naval launches captured by Confederates off Fort Sumter.

## 1865.

- January 1-31. Desultory firing on Fort Sumter; 64 shots in two days.

- January 15. Monitor Patapsco destroyed by torpedo off Fort Sumter; 62 lives lost.
- January 26. Gunboat Dai-Ching destroyed by battery at Burnet's, Combahee River.
- February 1. General Sherman's army, 70,000 strong, enters South Carolina from Savannah, Georgia.
- February 3. Confederates resist at Rivers's Bridge, Barnwell county.
- February 10-12. Union demonstration on James Island stubbornly resisted by force in rifle-pits at Grimball's, commanded by Major E. Manigault.
- February 11. Skirmish at Aiken with Union cavalry.
- February 12-16. Union expedition of land and naval force to Bull's Bay checked four days by Captain E. L. Parker's light battery and a small force of cavalry.
- February 15. Skirmish at Congaree Creek, near Columbia.
- February 17-18. Charleston harbor and city evacuated by night, after 587 days of continuous military operations against them. Columbia, the capital of the State, occupied by General Sherman's army.

## APPENDIX B.

### THE STEAM-FRIGATE NEW IRONSIDES.

THIS powerful sea-going, iron-clad steamer was the only one of her class built by the Navy Department of the United States during the Civil War. Being of the ordinary model in all essentials and capable of carrying canvas, the vessel was yet of exceptionally light draught for her displacement. This seems to have affected at times the steering, but never to any serious degree. And when all the offensive and defensive qualities of the ship are considered, the failure of the Government to follow up her construction with others of the same class is something unaccountable.

An act of Congress approved August 3, 1861, authorized the call for plans and specifications of armored vessels. From a large number of propositions only three were accepted. By recommendation of a naval board consisting of Commodores Joseph Smith and Hiram Paulding and Captain Charles H. Davis contracts were made the same fall for the building of the Monitor, the Galena, and the New Ironsides, each of different model.

#### DESCRIPTION OF THE VESSEL.

Contracted for October 15, 1861, launched May 15, 1862, and sent to sea on trial-trip August 21, 1862, the vessel was completed in ten months after contract. The builders were Merrick & Sons, Philadelphia.

Length over all . . . . .	249 feet 6 inches.
Depth of hold . . . . .	17 "
Beam, varying from 46 feet to . . . . .	57 feet 4 inches.
Draught of water . . . . .	16 feet.
Displacement . . . . .	3500 tons.



The ship had three decks ; was pierced for eight guns on each broadside ; was armed with fourteen XI-inch smoothbores and one or two 8-inch rifles (150-pounders). An armor-plating three inches thick, carried all around from four feet below the load-line to three feet above it, terminated forward in a ram four and a half feet deep and nine inches thick, projecting six feet from the stem. The sides above this line of plating fell back with a slope of five feet seven inches in a height of ten feet. The plating, solid, forged, four and a half inches thick—not laminated, inch thick, as for the monitors—covered these sides for a length of one hundred and seventy feet.<sup>1</sup>

The bow and stern were unplated, except near the water-line. On the gun-deck, fore and aft, were two iron-clad bulkheads, closed with rolling doors of solid plate iron five inches thick. These bulkheads thus “enclosed the gun-deck and proved an effectual barrier to a raking fire.” The spar-deck of wood was plated on the under side. Furnished with masts, which were made to be unshipped, and bark-rigged with lower and topsail yards, besides fore-and-aft-sails, she generally went without them, but they were deemed to be indispensable to her safety while on a voyage. She carried but ten days’ coal, burning nearly forty tons a day, and making on the way to Port Royal, with steam and sails, only six and a half knots. “Her motions, rolling and pitching in a sea-way,” Captain T. Turner reported, “are as easy as any ship I ever sailed in : indeed, I may say that they are graceful and playful, so buoyant is she, and taking in as little water as any frigate in service.” (*Armored Vessels*, Exec. Documents, vol. xiii.) Her complement of men was from four hundred to four hundred and fifty.

The pilot-house, a small iron turret capable of holding only three persons, was strangely located behind the large smokestack and furnished with the usual slits for outlook. An effort was made to remove the pilot-house forward soon after the ship’s arrival at Port Royal harbor, South Carolina, but found impracticable with the means at hand. The horse-power of the engines appears also to have given some dissatisfaction, as being not great enough in the case of a gale and the danger of a lee

<sup>1</sup> *Journal of the Franklin Institute*, vol. liii. No. 2.

shore. The ports were closed with iron shutters, and their dimensions were thought too contracted to allow as great elevation or lateral movement of the guns as was desirable.

#### SERVICES ON THE 7TH OF APRIL, 1863.

It is easy to perceive that Rear-Admiral DuPont's confidence in the power of his iron-clad squadron was greatly shaken before this attack. The engagements with the sea-coast batteries in Georgia had been discouraging, and while the monitors were falling under suspicion, the New Ironsides was still more distrusted when it became a question of engaging Fort Sumter and the other works at the entrance of Charleston harbor.

Nevertheless, the rear-admiral took the ship into action with his flag flying upon her, four monitors in advance and four others bringing up the rear, all in the formation of "the line ahead." About the time of the leading monitor's opening fire, the flagship, heading against the ebb tide, a strong current, must have slackened speed and drifted down and off to the eastern edge of the channel. This is said with the full reports and a chart of the harbor open before the writer; and the conclusion is, that if she came in as near as the rear-admiral says—1000 yards—she could have been in no danger of going ashore, for the soundings in channel at that distance and as far out as 2000 yards from Sumter are as follows:  $3\frac{3}{4}$  fathoms,  $5\frac{1}{2}$ , 9,  $6\frac{1}{2}$ , and  $7\frac{3}{4}$  fathoms. But the evidence of her being farther off than that, even on the extreme eastern limit of the channel, at this place a half mile wide, is convincingly given by her own commanding officer, although he agrees with the admiral in his estimate of distance. Captain Turner reports that "he found the ship frequently within a foot of the bottom," and he attributes to the extraordinary skill of the pilot "the fact that she was kept clear of it." Now, no soundings of seventeen feet or thereabout occur on the eastern limit of the channel, except at a distance of over 2000 yards from Fort Sumter. The ship's draught was sixteen feet, and she was reported "frequently within a foot of the bottom."

But the drifting, we are further told by the reports, was caused

by the ship's "becoming partly unmanageable."<sup>1</sup> The admiral says his vessel "could not be brought into such close action as I endeavored to get her; owing to the narrow channel and rapid currents she became partly unmanageable, and was twice forced to anchor to prevent her going ashore, once owing to her having come into collision with two of the monitors. She could not get nearer than one thousand yards." The channel is shown by the chart to have a width of at least half a mile to the left of her position and a depth of five or six fathoms.

With his well-known distrust of the ship, which he held to be "more vulnerable than the monitors" (Exec. Doc., *Armored Vessels*, page 79), it is fairly to be inferred that the admiral did not take her near enough to do herself any credit. The consequences were, that neither her offensive nor her defensive qualities were exhibited. Not a gun was fired at Fort Sumter, only seven at Fort Moultrie, and one at Battery Wagner. The ship was struck very often, but, being twice as far off as the monitors, her injuries were comparatively slight. The testimony of Captain Turner was as follows: "She lost one port-shutter, shot away. She had one of her plates cracked (through and through) by a shot. She had a breeching-bolt driven in. She received a shot on her beak which twisted it a little and cracked it. Whenever she was struck in her wooden work she was damaged—I cannot tell how many times. There was nothing to impair her efficiency in the slightest degree, either in her iron- or woodwork. She was as ready to go into the fight ten minutes afterward as she ever was."<sup>2</sup> Her captain continues: "No shot or shell entered the iron-clad part of the Ironsides. Some came in through the woodwork, but did not penetrate the sandbags. My impression is, that had it not been for the sandbags

<sup>1</sup>"When in shallow water, like all flat-floored vessels, she steered badly and became unmanageable if obliged to slow down or to stop the machinery" (italics not original). "The armor-plating was four and a half inches in thickness, and stood fairly the fire from all the batteries to which she was exposed at all times."—*Atlantic Coast, Rear-Admiral D. Ammen*.

<sup>2</sup>"Fort Sumter cripples the New Ironsides" is a statement by the author of *Military Operations of General Beauregard*, chapter xxx. vol. ii. I have found no evidence of the above. The ship was plainly less affected by the Confederate fire than her commanding officers appear to have been.

on the spar-deck I should have lost many of my crew. The iron plating of the spar-deck is confined to the wooden deck above it by iron bolts, half screwed. There were about thirty of these bolts over each gun. Wherever shots struck where there were no sandbags the bolts would be driven down like bullets; one shot did strike where there were no sandbags, and the bolts underneath were driven out by the concussion. All the woodwork, both forward and abaft the iron bulkhead, was barricaded by sandbags eight or nine feet in a horizontal direction nearly to the beams. Immediately before going into fight I turned the hose upon the sandbags, both fore and aft, and saturated them thoroughly with water: water was several inches deep in my cabin. I put green raw-hides on the spar-deck fore and aft, making a carpet of them from one end of the ship to the other; over these a layer of sandbags fore and aft as far as each iron bulkhead; these were some five or six inches thick. After the fight was over it could be seen where the shot struck the sandbags, as they were ripped up and the sand driven in all directions." (Exec. Doc., *Armored Vessels*, pages 148, 149.)

It is almost unnecessary to add that there were no casualties on board the flagship *New Ironsides* during the attack of April 7, 1863.

#### SERVICES IN JULY, AUGUST, AND SEPTEMBER, 1863.

These were principally against Morris Island, and incidentally against Sullivan's Island: on only one occasion did the guns of the *New Ironsides* fire upon Fort Sumter, and that was by night, after the fort had been silenced by the land-batteries. In July and August the ship took part with the monitors and gunboats in the siege of Battery Wagner, very greatly contributing to the common purpose.

This was notably the case July 18th, in preparation for the second assault that evening. For seven hours next preceding the assault the powerful batteries of the ship poured into the devoted work a perfectly overwhelming fire of 11-inch shells, aimed and exploded with the utmost precision. No less than 805 rounds were fired, and before the plucky little fort was

silenced—there were only two 10-inch smoothbores on the sea-face—the ship was struck ten times. On four other days, later in July, she engaged Wagner during ten hours, firing 964 rounds, and receiving from Wagner's one or two guns as many as thirty hits.

On seven occasions in August the guns were in action against Wagner, firing 1152 rounds, but with no response from the pigmy to the giant after the first day, August 17th, when thirty-one hits or more were received.

In order to let the veterans of Battery Wagner who may be left at this date read the effects of their fire, the following report is introduced. The 17th was the first day of the bombardment of Fort Sumter :

UNITED STATES SHIP NEW IRONSIDES, }  
OFF MORRIS ISLAND, Aug. 17, 1863. }

SIR: I have the honor to make the following report respecting the injuries received by this ship in the action of to-day (with Wagner). I count in all thirty-one hits, though I think we were struck several times below the water-line. The plating received nineteen shots, eleven others struck the woodwork, and eight passed through the smokestack. No material damage was done to the armor, though in four places the iron was so much crushed in as to crack it. The backing, except in one place where one width of the ceiling, just forward of No. 6 port on the starboard side, is driven in about three-fourths of an inch, shows no signs of having been started. The forward shutter of No. 3 port on the starboard side was shot off and lost overboard, having been struck on its upper edge near the pivot on which it swung. One shot came through the woodwork on the starboard quarter into the cabin and passed down into the wardroom, tearing out a large piece of the clamps in one of the cabin staterooms, ripping up the coaming of the wardroom hatch and splintering the beam underneath. One of the wheelropes which ran through the beam barely escaped being cut away by this shot. Another shot struck the deck, unprotected by sandbags, just abaft the partners of the mizzen mast, going through the planking and glancing off as it met the iron underneath. The iron, however, was crushed down to the depth of an inch and a half, and partially broken. The deck-pump on the starboard quarter was carried away, and the shot, striking the sandbags, glanced forward and remained on deck; but the knee supporting the beam underneath the place where the sandbags lay was split and one of the carlins broken.

All these hits were made by 10-inch solid shot, which seem to have

been fired with exceedingly heavy charges, some of them at a distance of not more than from nine hundred to one thousand yards.

Very respectfully,

T. H. BISHOP, *Carpenter.*

CAPTAIN S. C. ROWAN,

Commanding U. S. Steamer *New Ironsides.*

It is possible that a few of these shots may have been fired by Battery Gregg, or even Fort Sumter, as they both engaged the fleet the same day; but the artillerists of Battery Wagner certainly made fine practice with their two 10-inch columbiads against the terrible odds of the *Ironsides*, with her thundering broadside of seven XI-inch guns and one heavy rifle.

On the night of September 1st-2d the same ship accompanied the monitors up the channel to Sumter, and fired fifty shells into the grim ruin, which now at length, quite silenced by the land-batteries, had not a gun left to reply to the iron-clad squadron. The rear-admiral in his *Diary (Memoir)* says he received two shots from Sumter, but he is mistaken.

Next came two hot days' work before the silent but stubborn parapet of Battery Wagner in company with all the monitors and gunboats. These were the final days of the siege. On the 5th nine hours' firing, on the 6th thirteen hours' firing, being a total of 742 shots, added to the record, but all without the ships receiving any reply.

At length, when Morris Island was evacuated, the scene of naval action was changed for a few days to Sullivan's Island. The heavy works of Moultrie, Bee, and Beauregard, which took part in the action of April 7th, had been made stronger and been reinforced by other works since that date. Perhaps the greatest weight of metal was concentrated in Battery Bee, but the whole line of water-batteries extending from Bee to Beauregard, a distance of about 1800 yards, was truly formidable, second only to the powerful works of Fort Fisher on the coast of North Carolina.

The occasion was given on September 7th and 8th by the grounding of the *Weehawken* off Cumming's Point. As a diversion the iron-clads moved up "to go as close to the obstructions as was prudent," and consequently became engaged

with Fort Moultrie and all the adjacent batteries, mounting from thirty-five to forty guns of the heaviest (Confederate) calibre. The *New Ironsides*, Captain S. C. Rowan, accompanied the monitors, taking her station and *coming to anchor* off Moultrie, a distance of 1200 yards. Some of the monitors went in much nearer. They were all received with the hottest fire suffered since April 7th; the monitors sustained it for a half hour, the *Ironsides* for about one hour, the latter firing one hundred and fifty-two shells and receiving twenty-four hits. This action was brought on late in the afternoon of the 7th, and was followed by a heavier one next day.

After retiring for a while the ship was brought up again during the night, and, being ready for action in the morning, took nearly the same position as the evening before. From 11 A. M. to about 2 P. M., or nearly three hours, Captain Rowan held his vessel to the test with a thoroughness no previous commander had ever evinced. His report is perfectly correct in saying that this was "one of the severest artillery duels ever sustained by a ship through a space of two hours and fifty-five minutes." And it should be observed that she was *anchored* abreast of her antagonists during both of these actions. No other armored vessel before Charleston ever came to anchor before the enemy: in action the monitors were particularly restless.<sup>1</sup>

Nor was this anchoring of the *New Ironsides* in any degree like that other on April 7th, when, two thousand yards from Fort Sumter and "partly unmanageable," she was "twice forced to anchor to prevent her going ashore," with all the while a half mile of deep water between the enemy and herself.

By the report of the ordnance officer, Lieutenant H. B. Robeson, the ship fired on the 8th four hundred and eighty-three times and was hit seventy times, the range being 1200 yards, as the day before. Her commander's report includes no mention of damages, but the rear-admiral remarks that "the

<sup>1</sup> See Major Echols's report on April 7th in Appendix; the rear-admiral himself commenting upon this after one of the engagements. (See *Memoir*, Dahlgren, page 410.)

spar-deck, not included in the armor, exhibits evidence of the severe fire to which the vessel has been exposed." The casualties were only one officer and two seamen slightly wounded.

#### EXPERIENCES WITH TORPEDOES.

When the monitors left Charleston to go to Port Royal for repairs, five days after the fight of April 7th, the New Ironsides crossed the bar with them, but continued with the blockading fleet outside to protect the gunboats from another such raid as the Confederate rams had made on them in the early part of the same year.

It has been related in this volume (Chapter II.) how the flagship escaped destruction while becoming unmanageable on the 7th and drifting over a large electric torpedo sunk by the Confederates off Morris Island. This was a boiler containing three thousand pounds of powder: it had been placed in the main ship-channel to be exploded by wires extending to Battery Wagner, but the scheme failed.<sup>1</sup>

The next move planned against the entire armored squadron was to be a night-attack with small boats bearing spar-torpedoes. Suggested by General Beauregard, it was prepared, under Flag-Officer J. R. Tucker, by Lieutenant W. H. Parker of the navy, but was thwarted by the withdrawal of the squadron from its anchorage on the very day appointed for the expedition, April 12, 1863.

Another attempt, specially directed against the New Ironsides, was made by Captain J. Carlin, commander of a blockade-runner, on the night of August 21, 1863. Obtaining for his purpose, from Captain F. D. Lee of the Engineers, a hull fitted with

<sup>1</sup> Chas. G. de Lisle, assistant engineer, engaged in this work with Dr. John R. Cheves, Messrs. Waldron and Kates, reports under date May 26, 1863, that in laying the cable the steamer drifted, and thus an extra mile was added to the circuit, making the adjustment of the poles in the torpedo insufficiently near for the increased length of the cable. And this was the cause, he thinks, why the explosion failed to occur. He says the entire cable was examined subsequently and found in perfect order. (For report and sketches see *War Records*, vol. xiv. page 950.) I have seen no authority given for the story that the cable was cut on the beach of Morris Island by the passage of a heavy wagon.



steam-power, and one of the latter's spar-torpedoes carried at the bow, Captain Carlin, with a crew of volunteer sailors from the Confederate squadron in the harbor and a guard of eight soldiers from the garrison of Fort Sumter under Lieutenant E. S. Fickling, moved through the darkness upon the armored frigate. She was just then swinging with the tide, and presented her bulky form so unfavorably to the attack as to cause some confusion in the execution of the orders, so that Captain Carlin, finding himself about to run alongside instead of "bow on," and with his spar entangled in the anchor-chain of the frigate, decided to make off. With not a moment to lose, since the watch of the frigate was hailing and threatening him, he was further chagrined by the stoppage of his engine and the delay it occasioned. But, persevering in his efforts, he escaped without any loss. (See Captain Carlin's report in Appendix F.)

Next came, on the night of October 5-6, 1863, the equally daring and partly successful attack by Lieutenant W. T. Glassell of the Confederate Navy. A little boat<sup>1</sup> of peculiar construction, cigar-shaped, driven by a propeller with steam-power, nearly submerged, and armed with one of Lee's torpedoes (spar), was employed for the purpose. Taking with him only three men—J. H. Toombs, assistant engineer, James Sullivan, fireman, and J. W. Cannon, pilot, the engineer and fireman being from the gunboat *Chicora*, the pilot from the gunboat *Palmetto State*—Lieutenant Glassell made his way down the harbor soon after dark, arriving off Morris Island about nine o'clock. Passing along the eastern edge of the main channel, he reconnoitred the enemy's vessels lying at anchor and seen distinctly against the camp-fires of Morris Island, then entirely

<sup>1</sup> This boat, the first of the class known as "Davids," was built at his own expense by a citizen of Charleston, Mr. Theodore D. Stoney. He was aided in fitting it out by the counsel of Captain F. D. Lee and Dr. St. Julien Ravenel. Having a length of about thirty feet, a diameter of five and a half feet at its middle, and ballasted so as to float deeply in the water, it was painted above the line a bluish-gray color. The torpedo, carried at its bow by a hollow iron shaft about fourteen feet ahead of the boat, was a copper cylinder charged with "about one hundred pounds of rifle powder, and provided with four sensitive tubes of lead containing explosive mixture." Most of the particulars given in this account are obtained from a paper by Commander Glassell, contributed to the *Magazine of the Southern Historical Society*, vol. iv.

occupied by the Union forces under Major-General Q. A. Gillmore. The flagship, *New Ironsides*, was soon discovered in the midst of the fleet, with her starboard side presented to his view.

Putting on all steam and making for his object, he was discovered from the frigate's deck when about three hundred yards distant. Hailed several times rapidly, but giving no answer, he shortened the distance to about forty yards; then levelled his gun at the officer of the deck, Acting Ensign C. W. Howard, who had come to the side, and fired, mortally wounding him. The next moment the little boat struck the frigate between the gangway and the quarter, exploding the torpedo with full force. A column of water, raised instantly above the level of the spar-deck and descending into the engine-room of the *Ironsides*, was the means of disabling for a while her doughty little antagonist, for the same water put out the fires of the *David* and poured into the hull through the narrow hatchway. Seeing what appeared to be a desperate condition of things, Lieutenant Glassell gave the order to abandon the boat. The explosion had not damaged it, but the engine could not be reversed, and the boat drifted astern of the great ship. Meanwhile, the lieutenant and his companions, except Cannon, who could not swim, took to the water, himself escaping unhurt through a rain of bullets, until picked up after an hour's exhausting swim and made a prisoner. Sullivan also was captured, taken from the rudder-chains of the frigate, which he had caught in passing. Cannon held on to the drifting boat until rejoined by Toombs, who soon raised steam on it, and the two brought the *David* back to the city that night.<sup>1</sup>

<sup>1</sup>The expedition and all the actors were highly commended in general orders by General Beauregard. Glassell was promoted to the rank of commander, and after his exchange served on the *James River* until the close of the war. Toombs was made a chief engineer. Commander Glassell, a native of Virginia, was a lieutenant in the navy of the United States when the war broke out. Returning from China in 1862, he suffered about eight months imprisonment for not taking the oath; was exchanged and entered the navy of the Confederacy. Most of his service was in and around Charleston. Favoring the use of torpedoes in naval warfare, he encountered difficulties and discouragements, but, finally overcoming them, he will always be remembered as the first naval officer to conduct an attack with them and prove their efficiency. He died at Los Angeles, California, on the 28th of January, 1879.

On board the Ironsides the alarm for a while must have been terrible. The greatest uneasiness prevailed, as might with reason be expected, but the published official reports of the incident are scarce and barren of particulars. The rear-admiral was not on board at the time, but he tells how he hastened to the frigate as soon as possible. Though reporting only that "the outside of the hull near the locality of the explosion was examined by the divers, and it is reported to me verbally that no impression of any consequence is to be seen," he writes down in his *Diary*: "It seems to me that nothing could have been more successful as a first effort, and it will place the *torpedo* among *certain* offensive means." (*Memoir*, page 417.) The report made the next day to the rear-admiral by the captain commanding is equally devoid of details:

UNITED STATES STEAMER NEW IRONSIDES, }  
OFF MORRIS ISLAND, South Carolina, Oct. 6, 1863. }

SIR: I have the honor to report the circumstances attending the explosion of a torpedo against the side of the ship last night at a quarter-past nine o'clock.

About a minute before the explosion a small object was seen by the sentinels and hailed by them as a boat, and also by Mr. Howard, officer of the deck, from the gangway. Receiving no answer, he gave the order "Fire into her;" the sentinels delivered their fire, and immediately the ship received a very severe blow from the explosion, throwing a column of water upon the spar-deck and into the engine-room. The object fired at proved to be (as I subsequently learned from one of the prisoners) a torpedo-steamer, shaped like a cigar, fifty feet long by five feet in diameter, and of great speed, and so submerged that the only portion of her visible was the coamings of her hatch, which were only two feet above the water's edge and about ten feet in length.

The torpedo-boat was commanded by Lieutenant-commanding Glas-sell, formerly a lieutenant in our navy and now our prisoner. He states that the explosion threw a column of water over the little craft which put out the fires and left it without motive power, and it drifted past the ship.

Nothing could be seen from the gun-deck, and to fire at random would endanger the fleet of transports and other vessels near us. The marine guard and musketeers on the spar-deck saw a small object at which a very severe fire was kept up until it drifted out of sight, when two of the monitors, the Weehawken and Catskill, passed under our stern and were close to it, when it suddenly disappeared; two of our cutters were despatched in search of it, but returned without success.

I hope our fire destroyed the torpedo-steamer, and infer the fact from the statement of Lieutenant-commanding Glassell, who acknowledges that he and Engineer Tombs and pilot, who constituted the crew at the time of the explosion, were compelled to abandon the vessel, and, being provided with life-preservers, swam for their lives. Glassell hailed one of our coal-schooners as he drifted past, and was rescued from a grave he designed for the crew of this ship.

Very respectfully, your obedient servant,

S. C. ROWAN,  
*Captain commanding.*

The damages received by the New Ironsides in this encounter with the torpedo-boat would appear to have been exaggerated by the Confederates in about the same degree as they were suppressed by the Union authorities. Many of the former assert without proof that the steamer was "crippled" or "disabled so as never to fire another shot." She was neither crippled nor disabled, and she did fire many shots again, as will be proved in the sequel.

Her injuries, though not severe, were considerable,<sup>1</sup> and the general effect of the explosion was so formidable as to create to the end of the war the liveliest apprehensions of another

<sup>1</sup> "November 18. Captain Rowan came on board to report that in removing coal in bunkers of Ironsides it was discovered that the injury from torpedo was very serious, and extended down toward the keel."—(*Memoir Dahlgren*, page 426.)

In a paper contributed to the *Journal of the Franklin Institute*, February, 1867, vol. liii. No. 2. by J. Vaughan Merrick of Philadelphia, the builder of the New Ironsides, it is briefly stated concerning the injuries that "beyond driving a deck-beam on end, to shattering a knee," no material damage was done to the ship.

In the *History of the Confederate States Navy*, by J. Thomas Scharf, A. M., LL.D., New York, Rogers & Sherwood, 1887, it is stated, chapter xxiii. page 760: "Upon examining the New Ironsides it was found that the torpedo exploded only three feet under water, and against four and a half inches of armor and twenty-seven inches of wood backing. By the explosion the ponderous ship was shaken from stem to stern. It knocked down a bulkhead, started some timbers, and threw two or three rooms into confusion. A marine was dashed against the ceiling and his leg broken, while several other men were slightly injured." By reference to the builder's paper in the *Journal of the Franklin Institute* it will appear that the armor below the load-line for four feet was three inches thick, not four and a half, as stated by the author of the above history. His authority for particulars is not given.

such attack. The utmost vigilance and the most elaborate system of defense and protection were immediately inaugurated and constantly employed by all the vessels off Charleston harbor, and in particular by the New Ironsides. Picket-boats in abundance were on guard every night: hawsers stretched twenty feet distant around the frigate and the monitors, and held in place by projecting poles, acted as fenders against the dreaded danger. The frigate even employed two tugs to move around her like satellites every night, while a revolving calcium light flashed its rays in every direction. But the ship kept her anchorage, and remained on the station until June 6, 1864, having made a stay of eight months after the occurrence.

In the extremely heavy bombardments of Fort Fisher at the entrance of Cape Fear River, North Carolina, the New Ironsides took an active part. Under Rear-Admiral David D. Porter, and commanded by William Radford, commodore commanding iron-clad division, she was engaged at from thirteen to fifteen hundred yards for five hours on the 24th, and for seven hours on the 25th of December, 1864.

Again, on the days January 13, 14, 15, 1865, this ship, leading the iron-clad division, was engaged altogether for the space of twenty-eight hours, making a total before Fort Fisher of forty hours in action on five days. During all this time no injury is reported; only it is said by her commander that the armored vessels fought "without receiving any material damage."

Compiled from the figures given in the *Journal of the Franklin Institute* and from the official reports of the United States Navy, the following consolidated statements may be relied on as authoritative:

In action off Charleston harbor (July 18 to Sept. 8, 1863),  
68 hours 49 minutes.

Number of rounds fired, 4361, of which 3300 were at Battery Wagner.

In same period received 250 hits.

In action off Fort Fisher (Dec. 24, 1864, to Jan. 15, 1865),  
40 hours. No record of firing or hits discovered among the published official reports.

The *New Ironsides* was destroyed by fire at her anchorage near League Island, in the Delaware River below Philadelphia, December 16, 1866.<sup>1</sup>

<sup>1</sup> The following incident is related in a note appended to the *Memoirs* of Rear-Admiral Dahlgren, chapter xiv. page 426 :

"After the *Ironsides* had been struck by the torpedo it became important to know with certainty to what extent the hull had been affected externally under the water. The divers were therefore directed to examine. Their boat was brought alongside and a diver descended. It was low water, and the instant was seized when the tide ceased to ebb. The diver went carefully over the part of the bottom at the damaged portion, and then, reaching the keel, concluded to pass under it and look at the other side. He had accomplished this, and was on the other side, when he perceived that the ship was swinging to the newly-flowing tide. He had found just space between the bottom and the keel to pass under, and now saw that the vessel in swinging would pass close to a shoal ridge of the sandy bottom, and even grind into it. This must inevitably cut off the slender and delicate tube which conveyed air to him, and also sever the lines by which, in case of accident, he was to be drawn up. In the silence and solitude of those dark waters there was no human hand to avert the fearful consequence. Fastened down by his heavy weights, it would be instant suffocation.

"With all the speed that his incumbrances permitted, he endeavored to reach the keel and pass under it before too late. The ship was coming round rapidly; he passed his head and body, but began to feel the pressure of the keel against the soft ooze. With great effort he succeeded in dragging his tubes and limbs clear, and the water became a little deeper; but one arm was so painfully crushed that it was some days before it was in a condition to use."

*Opinions of Naval Officers.*

"The *Ironsides* is a fine, powerful ship."—(REAR-ADMIRAL DAHLGREN, June 28, 1864.)

"The *New Ironsides* I regard as a much more efficient type of iron-clad than the monitors just discussed, because of her possessing advantages over them in the particulars of fitness for general purposes, seaworthiness, relative strength of bottom or absolute capacity to endure vibration thereat, security against an antagonist vessel getting astride of her, speed, and habitability."—REAR-ADMIRAL L. M. GOLDSBOROUGH, Feb. 26, 1864.)

"I have never yet seen a vessel that came up to my ideas of what is required for offensive operations as much as the *Ironsides*."—REAR-ADMIRAL D. D. PORTER, Jan. 15, 1865.)

## APPENDIX C.

### NOTES OF IRON-CLAD WARFARE, 1854-82.

*Kinburn, Black Sea (Forts and Ships), October 17, 1854.*

THREE French sea-going gunboats, clad with rolled-iron plates 4.33 inches thick, backed by eight inches of oak, carrying each sixteen guns (68-pounders), engaged and silenced the Russian batteries, at close range, after five and a quarter hours' firing: the gunboats were but little injured.

*Charleston Harbor, South Carolina (Fort and Batteries), April 12, 13, 1861.*

In the bombardment and capture of Fort Sumter by the Confederates, two iron-clad batteries bore a prominent part. One was an earthwork for three guns, 8-inch columbiads, protected by a slanting shield (35°) of heavy timbers covered with railway iron, the rails fitting into each other alternately up and down, and presenting on the outside a smooth surface kept well greased for action. The shots from Fort Sumter, for the most part, glanced from this shield without penetration or injury. Planned and constructed by C. H. Stevens of Charleston, afterward brigadier-general, it was completely successful; but later in the war such shields on the Western river-batteries were riddled by the 10-inch shot of the gunboats. The other battery, known as the "floating battery," was protected by a high bulwark and slanting roof of heavy timber, covered with iron plates of one and a half to two inches thickness; its armament was four 42-pounders. It was frequently hit, but not seriously damaged, by the guns of Fort Sumter. The projector and constructor was Lieutenant J. R. Hamilton of Charleston, an ex-

officer of the United States Navy, and, later, of the Confederate Navy.

*Cumberland River, Tennessee (Forts and Ships), February, 1862.*

*Fort Henry, February 6th.*—Four iron-clad gunboats of Captain Eads's construction, plated with two and a half inches of iron over a backing of eight inches of oak, inclined 40°, carrying 15-inch and 10-inch guns; engaged fort fighting them with eleven guns until seven were silenced. Range from 1700 to 600 yards. Action lasted 1 hour 15 minutes, and resulted in the surrender of the fort. One iron-clad (*Essex*) entirely disabled.

*Fort Donelson, February 14th.*—Four gunboats, as above, fighting with twelve bow guns, engaged the fort, fighting with 10-inch guns. Range from 1700 to less than 400 yards. Action, lasting 1 hour 30 minutes, terminated in repulse of boats. The flag-ship *St. Louis* and the *Louisville* were wholly disabled, the former having received 59 shots; the two remaining boats were also greatly damaged.

*Hampton Roads (Ships), Virginia, March, 1862.*

The *Merrimac* (Virginia), steam-frigate razeed, casemated sides slanting 35°, of wood twenty-four inches thick, covered with four inches of iron, armed with eight 9-inch smoothbores and four 7-inch and 6-inch Brooke rifles, engaged at close quarters by the *Monitor* (Ericsson's plan), carrying two XI-inch guns, smoothbores, and covered on the turret with eight inches, on the sides with five inches, of iron plating. This action of March 9th was three hours in length, and was a drawn battle.

Captain Van Brunt, of the *Minnesota* frigate, reports that the *Monitor* withdrew first, and that then the *Merrimac* threatened to bear down on him. On April 11th and for several days following the *Merrimac* offered battle to the *Monitor* without success; and on May 8th the entire Union fleet, including the *Monitor*, was chased by the *Merrimac* from Sewell's Point to Old Point.



*Drewry's Bluff, James River, Virginia (Earthworks and Ships),  
May 15, 1862.*

Two armored and three unarmored vessels engaged Confederate land-battery, armed with three 8-inch (smoothbore) columbiads. After three hours' fighting, at an average of about 800 yards, the Galena (iron-clad) was penetrated in many places and disabled, and the squadron retired, with loss of 14 killed and 13 wounded. The bluff was somewhat over a hundred feet above the river.

*Charleston Bar, South Carolina (Ships), January 31, 1863.*

The Palmetto State and the Chicora, Confederate iron-clad gunboats, built with slanting casemated sides of timber twenty-two inches thick, covered with four inches of iron, and armed with 6- and 7-inch rifles and with 8- and 9-inch smoothbores, attacked, damaged, and drove off for seven hours the blockading fleet of nine wooden vessels.

*Great Ogeechee River, Georgia (Fort and Ships), March 3, 1863.*

Fort McAllister, seven guns, harmlessly bombarded for eight hours by three monitors, one of which, the Passaic, retired with her deck very badly injured: range, 1500 yards.

*Charleston Harbor, S. C. (Forts and Ships), April 7, 1863.*

The iron-clad squadron of nine vessels (one steam frigate and eight turreted boats) engaged the forts and batteries at the entrance of the harbor for two hours and a half, when they were forced to withdraw, with more than half their number partially disabled, one sinking next morning. (The particulars are given fully in Chapter II. of this work.)

*Warsaw Sound, Georgia (Ships), June 17, 1863.*

The Confederate iron-clad gunboat Atlanta, of the same build as the Palmetto State and Chicora, described above, was attacked at short range, and captured after a brief engagement, by the Federal monitors Weehawken and Nahant, armed with XV-

inch and XI-inch smoothbores. The Atlanta grounded early in the action, became a fixed target for the Weehawken, and was badly damaged by her heavy shot. The Nahant took no part, but was coming forward when the surrender occurred.

*Plymouth, N. C., and Albemarle Sound, N. C., April 19  
and May 5, 1864.*

Confederate ram Albemarle, two 7-inch rifles, engaged two gunboats off Plymouth, sinking one and driving off the other. Again, in Albemarle Sound, when attacked by eight or nine gunboats, this ram disabled one, and, after fighting for three hours, retired at nightfall with no serious injury. Her armor resisted solid shot of IX-inch smoothbores and 6-inch rifles, action at close quarters. Destroyed by torpedo-boat at anchorage, October 27, 1864.

*Mobile Bay (Ships), August 5, 1864.*

The Confederate ram Tennessee, stronger than any other built at the South, except the Arkansas, having an armor of six inches of iron laid upon twenty-five inches of timber, slanted 45° from the deck, carrying six Brooke rifles, but with inferior steam-power, attacked the entire Union fleet of fifteen or more vessels, among them three monitors. Invulnerable to most of their broadsides, she was exposed to their ramming attacks without sufficient steam-power to avoid them. The XV-inch shot of the monitors fired with heavy charges failed to penetrate her shield, with one exception. But with three port-shutters jammed, reduced to firing but three guns, with her smokepipe broken off close to the upper deck, and her rudder-chains cut away, she became unmanageable and was surrendered. The fight was at very close quarters.

*Lissa, Adriatic Sea (Ships), July 20, 1866.*

The Austrian fleet of seven armored and twenty unarmored vessels repulsed the Italian fleet of nine armored rams and frigates, two of which were lost. The casualties were heavy

on both sides. Italians, 650 drowned or killed and 40 wounded; Austrians, killed and wounded, 136.

*Peruvian War, Iquique Harbor (Ships), May 21, 1879.*

The Huascar and Independencia, Peruvian armored ships, engaged two Chilean unarmored gunboats. One, the Esmeralda, was sunk by the ram of the Huascar. The Independencia, chasing the other gunboat, grounded, and surrendered under fire; but the Huascar coming up, the gunboat left her prize and escaped. The Independencia was fired and abandoned by her crew.

*Coast of Peru (Ships), October 8, 1879.*

In this, the first and only action between seagoing iron-clad ships, the Peruvian steamer Huascar, armored on turret (revolving) with but five and a half inches, and carrying four guns (two 10-inch smoothbores and two 40-pounder Whitworth rifles), was met by two Chilean men-of-war, the Almirante Cochrane and Blanco Encalada, twin iron-clads. The latter, armored with nine inches of plating at water-level, from six to eight inches around the batteries, carried, each, six 9-inch Armstrong 12-ton guns, firing only Palliser shells. Action began at long range, with subsequent attempts at ramming and fighting at 300 yards, decreased at times to 100, and even 50 yards; lasted one hour and a half, when the Huascar, on fire, with three feet of water in the hold and nearly one-third of her crew killed or wounded, surrendered to the Chileans. The Huascar fired 20 rounds: the other vessels, 77 together. The Peruvian ship was greatly overmatched in armor and ordnance.

*Alexandria, Egypt (Forts and Ships), July 11, 1882.*

The English fleet, eight iron-clad seagoing steamers, with five gunboats, carrying altogether 102 guns, destroyed the forts and batteries, after firing ten and a half hours, with little loss to themselves (6 killed and 28 wounded), but with great loss to the Egyptians. The latter fought well, but with only 10-inch against 12-, 18-, 25-, and 81-ton guns, firing shells of 258, 410,

547, and 1704 pounds weight. The English ships were protected by armor varying from five and six inches to ten and twelve, and even from sixteen to twenty-four inches, of iron. In the fleet some guns were disabled, one ship having been struck twenty-five times. The forts (105 guns) had their strongest granite walls shivered, sometimes by a single shot, while sandbag work suffered little damage from the heaviest projectiles of the English. The strongest of the iron-clad ships was the *Inflexible*, of 9515 tons, 8483 horse-power, 23 feet draught, and a speed of 14.74 knots. She was armed with four 81-ton guns of 16-inch calibre, capable of penetrating twenty-two inches of iron at 1000 yards.

NOTE.—The Armstrong breech-loading rifle cannon, made for the Italian navy and tested at Spezia, had a weight of 100 tons; calibre, nearly 18 inches; length, 39 feet; diameter at breech, about 5 feet 5 inches; projectile of steel, about 4 feet 6 inches long, weight 2000 pounds; charge, 471 to 600 pounds; greatest penetration, 30 inches of wrought iron. More than half the gun made of steel, the remainder being wrought iron.

(September, 1887.) Krupp's great gun for the Italian navy weighs 118 tons, is 45 feet long, and its internal calibre is nearly 16 inches, rifled with ninety-two spiral turns. It throws a steel projectile weighing nearly one ton, with a charge of six cwt. of brown prismatic powder, having an initial velocity of 614 yards in a second and a range of nearly eight miles; the shot can penetrate a steel armor-plate thirty-six inches thick immediately at the mouth of the gun, and a plate of twenty-nine inches thick, it is estimated, at a distance of a mile or more.

## APPENDIX D.

### COLONEL DAVID B. HARRIS, CHIEF ENGINEER.

No account of the defense of Charleston by the Confederate forces would be complete without the strongest testimony to the services rendered for more than two years by this distinguished officer.

A native of Goochland county, Virginia, born in 1813, and graduated at West Point in the class of 1833, he entered the United States Army as a lieutenant of the First Artillery, and was soon after appointed Assistant Professor of Engineering at the Military Academy. Resigning his commission about the year 1836, he entered upon the quiet life of a planter in his mother State, and engaged in that occupation with good success for upward of twenty-five years.

When the Confederacy called for soldiers he repaired to the front, serving as captain of Engineers on the staff of General Beauregard, and actively engaged in all operations connected with Centreville and Bull Run. Subsequently ordered to the West, he had much to do with the powerful batteries at Island No. 10, Mississippi River, with Fort Pillow, Vicksburg, and other places. With General Bragg he went into Kentucky, and returned soon after to be ordered to Charleston with General Beauregard. Here, in the Department of South Carolina, Georgia, and Florida, his time was busily occupied in the planning and construction of forts and channel obstructions, heavy batteries and extensive lines. Major (and then Lieutenant-Colonel) Harris became one of the most highly esteemed officers of the General Staff.

Although aided by the superior knowledge of his commanding general, he had laid upon himself chiefly the problem of an entirely new system of sea-coast defense, made necessary since

the first years of the war by the improvements in iron-clad ships and heavy artillery. And how skilfully he discharged his duties around Savannah and Charleston, along the coast, up the inlets, on the banks, and in the channels of deep, navigable estuaries, substituting new for old works, enlarging, strengthening, and perfecting on a scale never before contemplated, is amply proved by the records of Forts McAllister, Sumter, Wagner, and Moultrie, of James and Sullivan's Islands, under all their severe ordeals of fire. And how also, in the midst of it, he threw himself constantly among the troops that were most exposed, sharing their dangers and winning their admiration by the coolest courage, the memory of many a survivor will testify to this day.

Suddenly called away to share with General Beauregard in the crisis of the defense of Petersburg, Virginia, where new demands of skill in field- and siege-work were made upon him, he rose at once to the highest reach of his engineering service, compelling admiration of his fertile resources and indomitable spirit. But it was the last active duty of his life, for upon his return to Charleston with the rank of brigadier-general, and as he was about to be put in command of its immediate defense, this soldier of many battles was carried off by a fatal attack of yellow fever, brought through the blockade from the tropics and prevalent in the city at that time. His death occurred in Summerville, near Charleston, on October 10, 1864.

The following is a copy of the letter addressed by General Beauregard to the widow of Colonel Harris:

"JACKSONVILLE, Ala., October 13, 1864.

"DEAR MADAM: I have just heard the painful news of the death by yellow fever, at Summerville, S. C., of your lamented husband, the late Colonel D. B. Harris of the Provisional Army, C. S., Engineers. By his demise the country has lost one of its ablest and most gallant officers, and I have lost one of my best and most valued friends. Peace be to his ashes! He has died in a noble cause.

"The cities of Charleston, S. C., and Petersburg, Va., should erect a monument to his memory.

"With a sad and sympathizing heart, I remain, dear madam,

"Your obedient and respectful servant,

"G. T. BEAUREGARD."

A well-merited tribute to his memory in the editorial column of the *Charleston Mercury*, October 12th, concludes with these words: "He united in a singular degree all the qualities which render an officer valuable to his country and dear to his men. Wary, yet fearless as a lion, gentle in manner, yet endowed with extraordinary tenacity of purpose, fully versed in all the theories of military science, yet never spurning the suggestions of practical good sense, a man of few words, yet always speaking to the point, of unblemished purity in private life, and above all, modest to a fault, he made himself beloved and honored wherever he went."

## APPENDIX E.

### THE STRATEGIC VALUE OF MORRIS ISLAND.<sup>1</sup>

THE subject is controversial, but it is so important to a right estimate of the defense of Charleston that some attention is due to it from every reader of this history, and more particularly from the military critic.

At first, the issue joined between Brigadier-General Ripley and General Beauregard was upon the question of the *defensive* value of the island. It is not necessary to review the arguments, which may be read cursorily in Chapter IV. of this work, and in full in chapter xxxiii. of the *Military Operations* of General Beauregard and in the appendix to the same.

Later, the issue raised by Major-General Gillmore in his *Report of Operations* proceeds upon a magnifying of the *offensive* value of the island. In so doing he is controverted by General Beauregard in a paper contributed to the *North American Review*, July, 1886, and proving that Charleston, not Morris Island, being the real object of military offensive operations, the possession of Morris Island was of little or no strategic value as a means to the end.

Premising that a calm discussion of the subject should carry with it no unwillingness to confess that errors were made in the Confederate defense, it is nevertheless the writer's present purpose to contend that the strategic value of Morris Island, whether defensive or offensive, was small indeed, even supposing that the game of battle had been played without any oversights on either side.

<sup>1</sup> The extensive changes of configuration and the inroads upon the island made by the ocean since the war rule this discussion out of all present or future applications.



## I.

Let it be first considered that the ground in question was an *island*, separated from the city by four miles of water and from the nearest island shore (James Island) by two miles of salt marsh intersected by creeks. The holding of this advanced position by any power in a defensive way must depend on easy as well as open communications. In the case of the Confederates the transportation was so constantly limited, inadequate, and strained as to make the supplies and reliefs extremely uncertain and precarious. Even fresh water was a scarce article. Yet it is obvious that occupation of such an island, if only to forestall an enemy armed with long-range guns, bestows upon it a relative value, inasmuch as it diverts him from other more vital points and gains time for interior protection. But if Morris Island had been abandoned to the Union army before its descent of July 10, 1863; if, unresisted, the long-range batteries had opened on Charleston within a few days from the northern extremity, Cumming's Point, as they did in the fall of that year,—what absolute value, with regard to the capture of the city or the evacuation of the harbor, would those batteries have possessed? None at all.

That the Confederate occupation of the island, and the holding of it in the face of combined land and naval forces for nearly two months, did lend to it a relative defensive value must be freely allowed. But all that twofold advantage, of diversion from James Island (the key of Charleston) and time gained for interior fortification, was due, not to the intrinsic defensive value of Morris Island, but to the fortuitous oversight of the other side, the error and failure of their powerful combined land and naval force to cut off communications between the island and the city, and even force the surrender of the garrisons of Wagner and Gregg. Both the Union commanders perceived this weakness and exposure of the defensive holding of the island.

Rear-Admiral Dahlgren was eager to land a regiment of marines on the rear of Battery Wagner.<sup>1</sup>

Elsewhere he writes General Gillmore: "I propose to land

<sup>1</sup> *Memoir*, page 406.

from boats one of your best regiments to assault the angle rearward and toward the water. I would also suggest a picked column of three or four hundred men to attack the angle rearward and landward, passing up Vincent's Creek ; for this I will also endeavor to furnish boats." (Despatch July 20, 1863.) To this General Gillmore replied: "I am pleased with the project. . . . I also like your plan of assaulting the work. If the navy can furnish sailors and marines for one of the columns of attack, I will supply the other or others, and a combined attack can be made on the work." The same project was urged, later, by the general upon the rear-admiral, as follows:

August 23, 1863: "I desire to call attention to the project frequently discussed and deemed practicable by us both, of investing Morris Island as soon as Sumter should be rendered harmless, and starving the enemy into terms. I think that I can close communication on my left as far out as to include Lighthouse Creek. Cannot picket-boats be managed between the mouth of that creek and your monitors, so as to complete the investment?"

And again, September 3, 1863: "The cutting off the enemy's communications with this island forms an important element in this plan, and I hope it may commence to-night." But it was never commenced ; it was neglected.

All this correspondence goes to prove that the absolute defensive value of Morris Island to the Confederates was small indeed, being only the result due to the neglect and oversight of their invaders, rather than to any intrinsic advantages of the island itself. It may be said that two attempts to assault Cumming's Point failed ; but the cutting of communications did not require an assault : it might have been effected by persistent dashes of armed boats upon the water, with fire of small-arms and howitzers, or even by the steady use of the calcium light upon the point night after night. The Confederates were weaker on the water than on the land.

But it has been said by some Confederate critics of General Beauregard that if Brigadier-General Ripley had been allowed to fortify the southern end of Morris Island, "not a brick in Charleston would have been thrown down." Such language is

poetical: it needs to be translated into prose. The facts were that Morris Island could not, through lack of labor, be fortified as it should have been, except at the expense and peril of James Island. There was lack of troops on both islands. "The holding of the position (Morris Island) was secondary to that of James Island, which must first be secured beyond peril, if possible, of surprise and capture." (General Beauregard to Secretary of War, July 20, 1863.)

Even General Gillmore in his report goes out of his way to establish the defensive value of Morris Island, *if fortified according to his plan*. He says: "With one such work located on the site of Fort Wagner, and another on the high sand-bluffs about two miles farther south, no enemy could have maintained a lodgment on the island for an hour." But what becomes of that plan of landing from the fleet a column on the beach in the rear of such a work—a plan that he liked, was "pleased with," when suggested by the admiral? Or has he forgotten that investment of the island and "starving the enemy into terms" which he vainly urged upon the admiral? Either of these projects would have proved fatal to the strongest and best-located works on Morris Island.

## II.

But it is time to consider whether the island can justly be said to have any but the slightest *offensive* value in the strategy of attack upon Charleston.

Did the demolition of Fort Sumter from Morris Island set the Union army or navy one foot nearer to Charleston than it had been before, "that of course being the ultimate object in view"? (General Gillmore's Report.)

Did the expenditure of fifty-one rifle-cannon, or, rather, did the loss of nearly three thousand men, killed and wounded, on Morris Island, set forward the desired movement?

Did the throwing of five thousand tons of metal at Forts Wagner and Sumter by the army and navy attain the end for which troops were sent by thousands to Generals Gillmore and Foster, and ships were manned or armored and despatched by scores to Admiral Dahlgren?

Did the piles of rubbish here and there in the streets of Charleston sum up any grand results of long-range rifle practice or of skilful siege-works on the narrow sea-beach of Morris Island, five miles distant?

If these questions must all be answered in the negative—and there is no escape from it—the conclusion is forced that only the slightest value of the offensive kind belonged to the occupation of Morris Island.

It may be contended that the blockade was made effective by the capture of the island. But this is not supported by General Gillmore's statement concerning Fort Wagner—viz.: "The fleet, in entering, was not obliged to go within effective range of its guns." (Report, page 43.) The main ship-channel could have been nightly strung with blockaders off Morris Island as well the year preceding its evacuation as the year following that event.

---

The views above advanced may thus be summarized as conclusive on these two points:

1. The defensive value of Morris Island, qualified primarily by difficulties of supply and communication on the Confederate side, was impaired further by repeated plans of investment, as feasible as they promised to be effective, on the Union side. But since these were never carried out, the island was proved by results to possess some relative defensive value in respect to time and diversion.

2. The offensive value of Morris Island was little more than transforming to Fort Sumter, annoying to the transportation of the harbor, and menacing to the city of Charleston.

## APPENDIX F.

REPORTS, CORRESPONDENCE, DESPATCHES, ORDERS, Etc. Etc.

### CHAPTER II.

#### *The Capture of Charleston—First Instructions.*

[Confidential.]

NAVY DEPARTMENT, May 13, 1862.

SIR: This Department has determined to capture Charleston as soon as Richmond falls, which will relieve the iron boats Galena and Monitor. These vessels, and such others as can be spared from Hampton Roads, will be sent to Bull's Bay under convoy of the Susquehanna.

The glorious achievements of our navy, inaugurated by yourself, give every reason to hope for a successful issue at this point, where rebellion first lighted the flame of civil war.

The War Department sends instructions to-day to General Hunter, with whom you will consult and with whom you will co-operate fully, unless the move should be purely naval, when he will render you every assistance.

Very respectfully, etc.,

GIDEON WELLS,  
*Secretary.*

Flag-Officer S. F. DUPONT,

*Commanding S. A. B. Squadron, Port Royal, S. C.*

#### *Second Instructions for the Capture of Charleston.*

[Confidential.]

NAVY DEPARTMENT, January 6, 1863.

SIR: The New Ironsides, Passaic, Montauk, Patapsco, and Weehawken (iron-clads) have been ordered to, and are now on the way to join, your command, to enable you to enter the harbor of Charleston and demand the surrender of all its defenses, or suffer the consequences of a refusal.

General Hunter will be sent to Port Royal with about ten thousand men, to act as shall be deemed best after consultation with yourself. The capture of this most important port, however, rests solely upon the success of the naval force, and it is committed to your hands to execute,

with the confidence the Department reposes in your eminent ability and energy. Successful at Charleston, the only remaining point within the limits of your command is Savannah. If this place can be captured by the iron-clads, attack it immediately under the panic which will be produced by the fall of Charleston. If part only of the iron-clads are required to make the attack at Savannah (and I trust such may be the case), send off the remainder under careful towage to Pensacola. If Savannah cannot be attacked with iron-clads, send, immediately upon the fall of Charleston, the New Ironsides and two of the others (convoyed) to Pensacola. Do not allow the New Ironsides to wait for her masts; she can be convoyed. The importance of striking a blow at once at Mobile in the event of the fall of Charleston will be apparent to your mind.

Very respectfully,

GIDEON WELLES,

*Secretary of the Navy.*

Rear-Admiral S. F. DUPONT,

*Commanding S. A. B. Squadron, Port Royal, S. C.*

[Confidential.]

NAVY DEPARTMENT, April 2, 1863.

SIR: The exigencies of the public service are so pressing in the Gulf that the Department directs you to send all the iron-clads that are in a fit condition to move, after your present attack upon Charleston, directly to New Orleans, reserving to yourself only two.

Very respectfully,

GIDEON WELLES,

*Secretary of the Navy.*

Rear-Admiral S. F. DUPONT,

*Commanding South Atlantic B. Squadron, Port Royal, S. C.*

[This despatch must have been received off Charleston about the time of the fight, April 7th.]

*Despatch of Rear-Admiral S. F. DuPont to Major-General D. Hunter.*

IRONSIDES, April 8, 1863.

MAJOR-GENERAL D. HUNTER:

MY DEAR GENERAL: I attempted to take the bull by the horns, but he was too much for us. These monitors are miserable failures where forts are concerned: the longest was one hour, and the others forty-five minutes, under fire, and five of the eight were wholly or partially disabled.

I am, general, yours most truly,

S. F. DUPONT.

*Report of Colonel Alfred Rhett of Engagement of 7th of April between  
Iron-clads and Fort Sumter, etc.*

HEAD-QUARTERS FIRST SOUTH CAROLINA ARTILLERY, }  
FORT SUMTER, April 13, 1863.

Captain WILLIAM F. NANCE, A. A. G., First Mil. Dist., S. C. :

CAPTAIN : I have the honor to make the following report :

The Abolition iron-clad fleet, consisting of the frigate *New Ironsides* and eight monitors, appeared in sight on Sunday morning, April 5th, inst., crossed the bar the same evening, and anchored in the main ship-channel.

At 2 o'clock P. M., April 7th, inst., the whole iron-clad fleet advanced to the attack in the following order: viz. four monitors were in the advance, led by the *Passaic*; the *Ironsides* came next, followed by three other single-turreted monitors; and the *Keokuk*, a double-turreted monitor, bringing up the rear.

At thirty minutes past 2 P. M. the long-roll was beaten and every disposition made for action.

At fifty-five minutes past 2 P. M. the garrison, regimental, and Palmetto flags were hoisted and saluted by thirteen guns, the band playing the national airs.

At 3 o'clock P. M. the action was opened by a shot from Fort Moultrie. At three minutes past 3 P. M., the leading vessel having approached to within about 1400 yards of the fort, she fired two shots simultaneously—one a XV-inch shrapnel, which burst; both passed over the fort. The batteries were opened upon her two minutes later, the firing being by battery. The action now became more general, and the four leading monitors taking position from 1300 to 1400 yards distant, the fire was changed from fire by battery to fire by piece, as being more accurate. The fire by battery was again resumed as occasion offered. The *Ironsides* did not approach nearer than 1700 yards. The whole fire of the batteries engaged was concentrated on the *Passaic* for thirty minutes, when she withdrew from the engagement, apparently injured. The other ships, each in turn, received our attention. The fire of both Fort Moultrie and this fort being now directed against the *Ironsides*, she immediately withdrew out of effective range. The other turreted monitors came under our fire in like manner as the preceding, slowly passing in front of the fort in an ellipse—one only, the last, approaching to about 1000 yards.

At five minutes past 4 P. M. the *Keokuk* left her consorts and advanced, bow on, gallantly to within 900 yards of our batteries. She received our undivided attention, and the effect of our fire was soon apparent. The wrought-iron bolts from a 7-inch Brooke gun were plainly seen to penetrate her turret and hull, and she retired in forty minutes, riddled and apparently almost disabled.

At twenty-five minutes past 5 P. M. the whole fleet withdrew. The iron-clads had been under our fire for two hours and twenty-five minutes. The Keokuk has sunk, one monitor was towed south on the morning of the 8th of April, instant, several were apparently injured, and the fact has been demonstrated that iron-clads of the monitor class are not invulnerable. . . .

For the effect of the fire of the enemy upon the fort I would respectfully refer to the report of engineer.

One 8-inch columbiad, old pattern, chambered gun, exploded. This gun was being fired at about one degree elevation, and it is my opinion that its bursting was caused by the shot rolling forward when the gun was run into battery. In firing at low degrees of elevation and at depression sabot-shot should be used.

One 42-pounder rifled gun was dismounted by recoil and temporarily disabled. One 10-inch columbiad was disabled by having the rear transom of its carriage shot away. Both guns were again ready for action in a few hours.

The garrison flag received a shot through the union. The regimental flag was much torn by fragments of shell.

The garrison, consisting of seven companies First South Carolina Artillery, was disposed of as follows:

1st. Captain D. G. Fleming, with Company B, seventy-eight men, in command of east parapet battery, assisted by Lieutenants F. D. Blake and Iredell Jones. Lieutenant J. M. Rhett, Company A, although on sick report, was assigned temporarily to Company B.

2d. Captain F. H. Harleston, with Company D, seventy-four men, in command of north-east parapet battery, assisted by Lieutenants McMillan King and W. S. Simkins.

3d. Captain J. Gadsden King, with Company F, in command of north-west parapet battery, assisted by Lieutenants A. S. Gaillard, John Middleton, and W. H. Johnson.

4th. Captain J. C. Mitchel, with Company I, seventy-eight men, in command of west parapet battery, assisted by Lieutenant J. S. Bee.

5th. Captain J. R. Macbeth, with Company E, seventy-seven men, in command of mortar battery and east casemate battery, assisted by Lieutenant J. J. Alston.

6th. Captain W. H. Peronneau, with Company G, seventy-seven men, in command of north-east casemate battery, assisted by Lieutenant E. S. Fickling.

7th. Captain C. W. Parker, with detachment Company C, fifty-five men, and detachment Company E, in command of north-west casemate battery, assisted by Lieutenants G. E. Haynsworth and K. Kemper.

8th. Lieutenant W. H. Grimboll, with regimental band, fifteen men, in command of second-tier casemate battery.

9th. Lieutenant William Clarkson, with detachment of twenty-five men



of Company B, Charleston battalion, posted in second tier of casemate as sharpshooters.

Lieutenant-Colonel J. A. Yates, having reported for duty on the morning of the 7th of April, was assigned to the immediate command of the parapet batteries. The casemate batteries were under the immediate command of Major Ormsby Blanding.

The following is the number of guns brought into action: Two 7-inch Brooke guns, four 10-inch columbiads, two 9-inch Dahlgrens, four 8-inch columbiads, four VIII-inch navy-guns, seven banded and rifled 42-pounders, one banded and rifled 32-pounder, thirteen smoothbore 32-pounders, seven 10-inch sea-coast mortars.

The following were the officers of the staff: Lieutenant S. C. Boylston, Adjutant; Captain T. M. Barker, Assistant Quartermaster; Captain S. P. Ravenel, A. C. S.; Reverend N. Aldrich, Chaplain; Sergeant-Major, C. P. Grunshig; and Quartermaster-Sergeant, William Nicoll. Lieutenant Charles Inglesby was Officer of the Day; Lieutenant J. G. Heyward was Officer of the Guard; Lieutenant E. P. Ravenel was Acting Ordnance Officer, assisted by Lieutenant James B. Heyward, Lieutenant of Ordnance.

The Medical Department was under charge of Surgeon Mat. S. Moore, assisted by Assistant Surgeon Samuel Muller.

Mr. Edwin J. White was present as Acting Engineer Officer.

The members of the Signal Corps were—T. P. Lowndes, Arthur Grimball, and Joseph W. Seabrook.

Several officers of General Ripley's staff were present during the engagement, and, in the absence of General Ripley, tendered their services to me.

Captain Benjamin Read, Assistant Adjutant-General, Colonel Edward Manigault, and Colonel St. Clair Dearing were present, having tendered their services also.

Mr. Lacoste also was present and rendered efficient service. . . .

For expenditure of ammunition I would respectfully refer to enclosed report of Ordnance Officer.

For a list of casualties I would also refer to enclosed Surgeon's report.

At 9 o'clock A. M., April 8th, the Keokuk was seen to sink near Morris Island beach, where she now lies.

Respectfully submitted,

ALFRED RHETT,  
*Colonel, commanding.*

[AUTHOR'S NOTE.

It is to be regretted that no complete roster of this fine regiment has yet been obtained. As supplementary to the names of officers given above in Colonel Rhett's report or mentioned elsewhere in this volume, the following are added, and may be considered accurate as far as they go:

*Company A*: Captain William Campbell Preston, promoted major and transferred to the West, serving under Generals Johnston and Hood until he was killed in action near Atlanta, Ga., July 20, 1864.

Captains H. S. Farley and J. A. Sitgreaves, Lieutenants T. G. Dargan, Furman Dargan, Eldred Simkins, John Harleston, James S. Reynolds, James L. Robertson, Alfred Ayer, H. W. DeSaussure, T. Middleton, W. E. Erwin, Oscar LaBorde, Henry M. Stuart. (The two last named were killed in action at Averysboro', North Carolina.)]

W. F. COLCOCK, JR.

*Rear-Admiral DuPont's Report of the Attack.*

FLAGSHIP NEW IRONSIDES,  
INSIDE CHARLESTON BAR, April 8, 1863. }

SIR: I yesterday moved up with eight iron-clads and this ship, and attacked Fort Sumter, intending to pass it and commence action on its north-west face, in accordance with my order of battle.

The heavy fire we received from it and Fort Moultrie, and the nature of the obstructions, compelled the attack from the outside. It was fierce and obstinate, and the gallantry of the officers and men of the vessels engaged was conspicuous.

This vessel could not be brought into such close action as I endeavored to get her: owing to the narrow channel and rapid current she became partly unmanageable, and was twice forced to anchor to prevent her going ashore, once owing to her having come into collision with two of the monitors. She could not get nearer than 1000 yards.

Owing to the condition of the tide and unavoidable accident, I had been compelled to delay action until late in the afternoon; and toward evening, finding no impression made upon the fort, I made the signal to withdraw the ships, intending to renew the attack this morning.

But the commanders of the monitors came on board and reported verbally the injuries to their vessels, when, without hesitation or consultation (for I never hold councils of war), I determined not to renew the attack, for in my judgment it would have converted a failure into a disaster; and I will only add that Charleston cannot be taken by a purely naval attack, and the army could give me no co-operation. Had I succeeded in entering the harbor, I should have had twelve hundred men and thirty-two guns, but five of the eight iron-clads were wholly or partially disabled after a brief engagement.

The reports of the commanding officers will be forwarded with my detailed report, and I send Commander Rhind home with this despatch, whose vessel sank this morning from the effects of the bombardment yesterday, and who will give the Department all the information it may desire.

I have alluded above only to Forts Sumter and Moultrie, but the

vessels were also exposed to the fire of the batteries of Cumming's Point, Mount Pleasant (?), the Redan (?), and Fort Beauregard.

Very respectfully, your obedient servant,

S. F. DUPONT,

*Rear-Admiral, commanding S. A. B. Squadron.*

Hon. GIDEON WELLES,  
*Secretary of the Navy.*

P. S. I forward herewith a list of the casualties on board the Keokuk and Nahant.

*Instructions of the President.*

[Telegram.]

EXECUTIVE MANSION,  
WASHINGTON, April 13, 1863. }

Hold your position inside the bar near Charleston, or, if you shall have left it, return to it and hold it till further orders. Do not allow the enemy to erect new batteries or defenses on Morris Island. If he has begun it, drive him out. I do not herein order you to renew the general attack. That is to depend on your own discretion or a further order.

Admiral DUPONT.

A. LINCOLN.

[The admiral had left Charleston before this despatch was sent, and did not return inside the bar.]

*Further Instructions of the President.*

EXECUTIVE MANSION,  
WASHINGTON, April 14, 1863. }

This is intended to clear up an apparent inconsistency between the recent order to continue operations before Charleston, and the former one to remove to another point in a certain contingency. No censure upon you, or either of you, is intended: we still hope that, by cordial and judicious co-operation, you can take the batteries on Morris and Sullivan's Islands and Fort Sumter. But whether you can or not, we wish the demonstration kept up for a time, for a collateral and very important object. We wish the attempt to be a real one (though not a desperate one) if it affords any considerable chance of success. But if prosecuted as a *demonstration* only, this must not become public or the whole effect will be lost. Once again before Charleston, do not leave till further orders from here: of course this is not intended to force

you to leave unduly exposed Hilton Head or other near points in your charge.

Yours, truly,

A. LINCOLN.

General HUNTER and Admiral DUPONT.

P. S. Whoever receives this first, please send a copy to the other immediately.

A. L.

*Major Echols's Report of the Attack.*

C. S. ENGINEER'S OFFICE, }  
CHARLESTON, S. C., April 9, 1863. }

Major D. B. HARRIS, Chief Engineer Department:

MAJOR: I have the honor to make the following report of the engagement between Fort Sumter and the enemy's iron-clad fleet on the 7th of April, 1863, at 3 o'clock P. M., lasting two hours and twenty-five minutes.

The incidents which transpired during the engagement are based upon information received from the officers in charge of the works, but more particularly from the observations of Colonel Rhett, commanding Fort Sumter, and Lieutenant S. C. Boylston, Adjutant First regiment South Carolina Artillery, who made special observations during the whole action; the remainder from my personal inspection afterward.

The leading vessel received the first gun of the engagement. It was fired by Fort Moultrie, and was immediately followed by a volley from Fort Sumter, which had previously trained her barbette guns on the buoy, and opened fire by battery when that position was reached.

The first turret opened fire at five minutes past three, and moved backward, thus developing the manœuvre of attack. At this moment the engagement became general. The second turret passed the first, fired, moved backward; the first moved forward, passed the second, fired and backed, then retired from action, the other turrets manœuvring in the same relative manner, each time nearing or receding a little from the fort, in order not to present a permanent target.

The Ironsides, when at 1700 yards from Moultrie and 2000 yards from Sumter, stopped, discharged a battery at the former, and immediately drew upon herself a heavy fire; numbers of shot were seen to strike her, and several to penetrate. Apparently deeming 2000 yards too close quarters, she retired out of range after an engagement of forty-five minutes. The Keokuk at five minutes past four defiantly turned her prow toward Sumter, and, firing from her forward turret, moved up for close action. The guns of Sumter, Moultrie, Bee, and Cumming's Point were all concentrated upon her. Her turrets received numbers of well-directed shots, several evidently penetrating and damaging in their effects. When within 900 yards of Fort Sumter she was struck near

the bow by a wrought-iron bolt (117 pounds) from a 7-inch Brooke's rifle *en barbette*. The bolt penetrated, ripping up a plating about six feet long and two and a half wide. Upon this she stopped, seemed disabled for a few minutes, then turned to the channel and proceeded toward the bar, at forty-five minutes past four. She sank off the south end of Morris Island at half-past eight o'clock the following morning: her smokestack and turrets are now visible at low water. From her wreck floated ashore a book, a spy-glass, and pieces of furniture bespattered with blood and showing small fragments of iron sticking in them. . . . To the best of my judgment according to the effect, eight XV-inch shells struck the faces: two of these penetrated the wall of the eastern face, just below the embrasures in the second tier, next to the east *pan-coupe*, not seriously damaging the masonry; one, exploding in the casemate, set fire to some bedding; the other passed through a window and burst in the centre of the fort. Several exploded in contact with the wall, by which the principal craters appear to have been formed; one passed over the parapet into the quarters on the western side, exploded, damaging several walls; five XI-inch shot struck the faces, one penetrating near one of the same embrasures pierced by the XV-inch shell, broke through and stuck in the interior walls of the quarters; only one impression presented any appearance of a rifle projectile. . . . Our projectiles generally broke in pieces, as could be seen by fragments falling in the water or bounding from the vessel. One, after striking, was observed to drop and rest at the foot of the turret. Several of the smokestacks were riddled. . . .

I arrived at Fort Sumter about two o'clock at night after the engagement, and found Mr. E. J. White, Assistant Engineer, busily engaged building with sandbags in the casemates, first and second tiers, behind the damaged walls; several of them were completed and considerably strengthened. This work was continued all night and the next day by the garrison and the fifty negroes who had been employed at the fort and remained during the engagement. On the following morning the fleet lay inside the bar, in the same line of battle in which they approached—the first one about two and a half miles from Sumter and one and a half miles from Morris Island. Men were visible all day on the turret of one, hammering, evidently repairing her plating. About noon one of the turrets went south, probably to Port Royal for repairs.

The Ironsides has kept up a full head of steam since the engagement, as can be seen by her constantly blowing off. Three shot-marks are distinctly seen in the stern, two just above the water-line.

The "Devil" (torpedo-raft) floated ashore on Morris Island, the cables by which it was attached to the turret's bow having been cut away. It is probable that the "Devil," becoming unmanageable, was the cause of the turret retiring early from the action. It appears to be a massive structure, consisting of two layers of white-pine timbers, eighteen inches

square, strongly bolted together; having at one end a re-entering angle twenty feet deep to receive the bow of the vessel. In dimensions the "Devil" was fifty feet long and twenty-seven feet wide—a layer of bevelled timbers on the front form a bow; on the deck were seven heavy iron plates with hawser-holes, through which passed chains directly down and over the sides; to these at the sides and bow were suspended underneath grappling-irons with double prongs; in the countersinks of the plates were loose iron rollers, apparently to facilitate the drawing of the chains through the holes when the grapnels took hold, so as to bring to the surface whatever may have been caught. . . .

Very respectfully,

Your most obedient servant,

WM. H. ECHOLS,

*Major Engineers.*

Official:

G. THOS. COX, *Lieutenant Engineers.*

*Report of Brigadier-General J. H. Trapier, C. S. Army, commanding on Sullivan's Island, 7th of April, 1863.*

HEAD-QUARTERS 2D SUBDIVISION 1ST MIL. DIST., }  
SULLIVAN'S ISLAND, April 13, 1863. }

CAPTAIN: I have the honor to submit the following report of the action of the 7th inst. between the enemy's fleet of iron-clad war-vessels and the forts and batteries on this island.

At about 2 o'clock P. M. on that day it was reported to me that the movements of the fleet, which had been for some hours anchored within the bar, were suspicious, and that some of the vessels appeared to be advancing. So stealthily did they approach, however, that not until 2.30 o'clock did I become convinced that the intentions of the enemy were serious, and that the long-threatened attack was about to begin. I immediately repaired to Fort Moultrie, where I had previously determined to make my head-quarters during the action. Slowly but steadily the iron-clads approached, coming by the middle or Swash Channel in single file, the Passaic (it is believed) in the van, followed by the rest (eight in number) at equal distances, the flagship *New Ironsides* occupying the centre. At 3 o'clock Colonel William Butler, commanding in the fort, reported to me that the leading ship was in range. I ordered him immediately to open his batteries upon her, which was done promptly, and the action began. Fearing that the range was rather long for effective work, the firing after a few rounds was suspended for a short time, but finding that the enemy refused closer quarters, there was no alternative but to engage him at long range or not at all. We decided upon the former, and Fort Moultrie again opened her batteries. Batteries Bee and Beauregard had also by this time opened fire, and the action

had become general. It soon became obvious that the enemy's intention was to fight, and not to run by, and orders were given to "train" on vessels nearest in and to fire by battery. Volley after volley was delivered in this way, but, although it was plain that our shot repeatedly took effect—their impact against the iron casing of the enemy being distinctly heard and seen—yet we could not discover but that the foe was indeed invulnerable.

About 5.30 P. M., or after the action had lasted about two hours and a half, the enemy slowly, as he had advanced, withdrew from the contest, apparently unharmed, so far, at least, as his powers of locomotion went. Subsequent events have happily revealed the fact that one at least of our enemy's "invulnerables" has given proof that brick walls and earthen parapets still hold the mastery.

The nearest that the enemy ventured at any time to Fort Moultrie was estimated at 1000 yards; to Battery Bee, 1600 yards; to Battery Beauregard, 1400 yards.

Fort Moultrie was garrisoned by a detachment from the First regiment South Carolina regular Infantry, Colonel William Butler commanding, assisted by Major T. M. Baker, and consisted of the following companies: Company A, Captain T. A. Huguenin; Company E, Captain R. Press Smith, Jr.; Company F, Captain Burgh S. Burnet; Company G, First Lieutenant E. A. Erwin commanding; Company K, Captain C. H. Rivers.

Battery Bee was garrisoned by another detachment from the same regiment, commanded by Lieutenant-Colonel J. C. Simkins, and consisted of the following companies: Company C, Captain Robert De Treville; Company H, Captain Warren Adams; Company I, Captain W. T. Tatom. Colonel L. M. Keitt, Twentieth regiment South Carolina volunteers, by my consent, took post at Battery Bee, and remained there during the action.

Battery Beauregard was under the command of Captain J. A. Sitgreaves, First South Carolina regular Artillery, and was garrisoned by the following companies: Company K, First South Carolina regular Artillery, First Lieutenant W. E. Erwin commanding; Company B, First South Carolina regular Infantry, Captain J. H. Warley commanding.

It gives me pleasure to have it in my power to report that not a single casualty occurred among any of these troops, with the exception only of one in Fort Moultrie. Early in the action our flagstaff was shot away, and in falling struck Private J. S. Lusby, Company F, inflicting a severe wound, from which he died in a short time. Neither the fort itself nor its material was in the least injured.

It is due to the garrison of Fort Moultrie, and their soldierly and accomplished commander, Colonel Butler, that I should not close this report without bearing testimony to the admirable skill, coolness, and

deliberation with which they served their guns. They went all, men as well as officers, to their work cheerfully and with alacrity, showing that their hearts were in it. There was enthusiasm, but not excitement. They lost no time in loading their guns, but never fired hastily or without aim. The reports of Colonel Keitt, Lieutenant-Colonel Simkins, and Captain Sitgreaves give me every reason to believe that the garrisons of Batteries Bee and Beauregard acquitted themselves equally well, and are equally entitled to the thanks of their commander and their country. Colonel Butler makes honorable mention of the following officers:

Captain William H. Wigg, A. C. S., when the flagstaff was shot away promptly mounted a traverse and placed the regimental flag in a conspicuous place upon it. Captain G. A. Wardlaw, Assistant Quartermaster, and Lieutenant and Adjutant Mitchell King, and First Lieutenant D. G. Calhoun, were likewise prompt in placing the battle and garrison flags in conspicuous positions. Lieutenant Williams, Ordnance Officer, is also favorably mentioned.

To Captains William Greene and B. G. Pinckney of my staff, and First Lieutenant A. H. Lucas, my aide-de-camp, I am indebted for valuable assistance; and my thanks are also due to Lieutenant-Colonel O. M. Dantzer and Dr. G. W. Westcott, volunteer aides for the occasion.

I have the honor to transmit herewith a statement in tabular form, showing the expenditure of ammunition at Fort Moultrie and the batteries during the action.

All which is respectfully submitted,

J. H. TRAPIER,  
*Brigadier-General, commanding.*

Captain W. F. NANCE, *A. A.-G.*

*Report of Major C. K. Huger, South Carolina Artillery, commanding Artillery on Morris Island.*

BATTERY WAGNER, MORRIS ISLAND, }  
April 8, 1863. }

COLONEL: I have the honor to report that during the engagement yesterday this battery fired twenty-two shots, and the one at Cumming's Point sixty-six; nobody hurt at Cumming's Point, but I regret to have to report that from the accidental explosion of an ammunition-chest I have had at this battery eight casualties—viz. killed, Sergeant G. W. Langley, Privates Amos Fitzgerald and Jerry Dyer; wounded, Second Lieutenant G. E. Steedman, not dangerously; Corporal Matthew Martin; Privates, Samuel Red, seriously; Marion Quillan and Thomas Prince,



slightly; total, 3 killed and 5 wounded, all of the Mathewes Artillery, Captain J. Raven Mathewes.

There was no opportunity for any display of gallantry, but all did their duty with cheerfulness and promptness. The guns of this battery were of too light a calibre to be of much service, but those at Cumming's Point (Battery Gregg), under the immediate command of Lieutenant H. R. Lesesne of First Artillery, were much heavier, and the firing was particularly good.

Very respectfully, your obedient servant,

C. K. HUGER,

*Major, commanding Artillery Morris Island.*

Colonel R. F. GRAHAM,

*Commanding Morris Island.*

[In reply to a statement of Hon. William H. Seward, U. S. Secretary of State, that the attack of the 7th of April "failed because the rope obstruction in the channel fouled the screws of the iron-clads, and compelled them to return after passing through the fire of the batteries," the following extracts from letters of Brigadier-General Ripley, Colonel Butler, and Colonel Rhett will be found important:]

HEAD-QUARTERS 1ST MIL. DIST., }  
CHARLESTON, Oct. 12, 1863. }

I have to remark that the statement is simply false. The mendacious particulars are—

1st. "That the rope obstructions fouled the screws of the iron-clads," etc. These would probably have fouled the screws, besides producing other effects, but no Abolition iron-clad came within 300 yards of them.

2d. "After passing the fire of the batteries." But one of the fleet came within 900 yards of Fort Sumter or 1000 from the batteries on Sullivan's Island. . . . None ever came within effective range of the heaviest batteries at all. . . .

R. S. RIPLEY,

*Brigadier-General, commanding.*

Brigadier-General THOMAS JORDAN,

*Chief of Staff.*

HEAD-QUARTERS ARTILLERY W. END SULLIVAN'S I., }  
Oct. 9, 1863. }

CAPTAIN: . . . . The statement of Mr. Seward is, I beg leave to say, incorrect in several particulars. Being in a position where I could obtain a good view of the action, I submit as a fact that none of the iron-clads approached within several hundred yards of the obstructions, and therefore the screws could not have been fouled by them. . . . The iron-

clads were not, at any time, within fair range of the heaviest guns in position on Sullivan's Island. . . .

WILLIAM BUTLER,  
*Colonel, commanding.*

Captain W. F. NANCE,  
*Assistant Adjutant-General First Military District.*

HEAD-QUARTERS 1ST REGT. SOUTH CAROLINA ARTILLERY, }  
CHARLESTON, Oct. 12, 1863. }

GENERAL: . . . . The obstructions lay between Forts Sumter and Moultrie. During the attack on Fort Sumter I was on the parapet of the fort, observing closely with a glass, and causing notes to be taken of the progress of the fight in regard to time, distances, movements, and results. So far from passing through the fire of our batteries, the object of the enemy appeared to be to engage Fort Sumter at the longest effective range of their XV-inch guns. At no time did any of them enter within the fire of our heaviest batteries, which did not bear out to sea. The leading vessel, the Weehawken, approached, under the fire of our guns, as near as 1300 yards of Fort Sumter and 600 yards of the obstructions, and passed back out of range in an ellipse. The other vessels in turn followed the course of the Weehawken, the Ironsides having come to anchor at about 1800 yards from Fort Sumter and about one and a quarter miles from the obstructions. Two vessels only, the Keokuk and the Nahant, the last engaged, came nearer than 1300 yards of Sumter. The Keokuk left the line and came in toward the fort about 900 yards. Becoming disabled by the effect of our shots, she drifted in with the flood-tide to about 300 yards of the obstructions, when she managed to get under way again, and passed out of range in a sinking condition. The next morning she sank in shoal water in full view. This was the only vessel that came at any time as near as 300 yards of the obstructions. The Nahant, in support of the Keokuk, came as near as 1100 yards from Sumter, and occupied that position for a short time.

ALFRED RHETT,  
*Colonel, commanding First regiment S. C. Artillery.*

General THOMAS JORDAN,  
*Chief of Staff.*

HD-QRS. DEPT. SOUTH CAROLINA, GEORGIA, AND FLORIDA, }  
CHARLESTON, S. C., April 22, 1863. }

GENERAL S. COOPER,  
*Adjutant- and Inspector-General, Richmond, Va. :*

GENERAL: The work on the marine torpedo-ram is at a standstill for want of material and money. It will be remembered that the work was undertaken with the understanding that the sum of \$50,000 would be supplied by the State of South Carolina, and such material as the Navy

Department had available. . . . Meantime, the great value of the invention has been demonstrated so as to secure general conviction; and Captain Tucker, commanding Confederate States naval forces afloat on this station, declares unhesitatingly that this one machine of war, if finished, would be more effective as a means of defense and offense than nearly all the iron-clads here, afloat and building—a fact of which I am fully assured. Had it been finished and afloat when the enemy's iron-clads entered this harbor several weeks ago, but few of them probably would have escaped. Be that as it may, I trust the Department will have the matter inquired into; that is, the relative value, as war-engines, of the Lee torpedo-ram and of the iron-clad rams Chicora and Palmetto State and others of the same class now building in this harbor, to the absorption of all the material and mechanical resources of this section of the country.

I cannot express to the War Department in too strong terms my sense of the importance of the question involved, and of its intimate connection with the most effective defense of this position. I do not desire to impose my views, but feel it my duty to urge an immediate investigation by a mixed board of competent officers, to determine whether it be best for the ends in view to continue to appropriate all the material and employ all the mechanical labor of the country in the construction of vessels that are forced to play so unimportant and passive a part as that which Captain Tucker, C. S. Navy, their commander, officially declares to me must be theirs in the future as in the past. . . .

G. T. BEAUREGARD,  
*General, commanding.*

---

### CHAPTER III.

*Letter of the Secretary of the Navy to Rear-Admiral DuPont in Reply to Despatch of April 22d.*

NAVY DEPARTMENT, May 15, 1863.

. . . . “While complaining of the criticism of the Baltimore paper, you express your disappointment that your official report is not published. What public benefit, let me ask, could be derived from its publicity? . . . .

“I have not published your reports because, in my judgment, duty to the country forbade it. They may justify the failure at Charleston and excuse your abandoning, after a single brief effort, a purpose that the nation had deeply at heart, and for which the Department had, with your concurrence and supposed approval, made the most expensive and formidable preparations ever undertaken in this country; but such publications could have inspired no zeal among loyal men and would have encouraged those in rebellion.

“In abandoning the great object for which we have labored for so many months, and precipitately withdrawing from the harbor, your motives have not been questioned; but I have not deemed it expedient or wise to publish to the world your reports of your failure and your hopelessness of success. . . . It has not appeared to me necessary to your justification that the powers of assault or resistance be depreciated, and I regret that there should have been any labored effort for that purpose.”

Very respectfully,

GIDEON WELLES,  
*Secretary of the Navy.*

Rear-Admiral S. F. DUPONT,  
*Commanding S. A. B. Squadron, Port Royal, S. C.*

*Rear-Admiral DuPont's Reply to the Secretary of the Navy.*

FLAGSHIP WABASH,  
PORT ROYAL HARBOR, May 27, 1863. }

. . . . “I desire to call the attention of the Department to the statement that I precipitately withdrew from the harbor of Charleston, abandoning the great object for which we had labored for so many months. This charge is a serious one and highly derogatory to my professional character. When I withdrew the iron-clad vessels from action on the evening of the 7th of April, I did so because I deemed it too late in the day to attempt to force a passage through the obstructions which we had encountered, and I fully intended to resume offensive operations the next day; but when I received the reports of the commanders of iron-clads as to the injuries those vessels had sustained, and their performance in action, I was fully convinced that a renewal of the attack could not result in the capture of Charleston, but would, in all probability, end in the destruction of a portion of the iron-clad fleet, and might leave several of them sunk within reach of the enemy (which opinion, I afterward learned, was fully shared by all their commanders). I therefore determined not to renew the attack.

“But had not my professional judgment, sustained by all my commanding officers engaged in the attack, decided against further operations, I would have felt compelled by the imperative order of the Department, dated the 2d of April and received the 9th, to withdraw my vessels. The words of this despatch I beg leave to recall to the attention of the Department:

“‘The exigencies of the public service are so pressing in the Gulf that the Department directs you to send all the iron-clads that are in a fit condition to move after your present attack upon Charleston, directly to New Orleans, reserving to yourself only two.’

“Accompanying this despatch was an unofficial letter from the Assist-

ant Secretary giving the reasons for this order, and closing with the remark: 'This plan has been agreed upon after mature consideration, and seems to be imperative.'

S. F. DUPONT,  
*Rear-Admiral.*

[From *Battles and Leaders of the Civil War*, Century Co.]

*South Atlantic Blockading Squadron (January-July, 1863).*

Rear-Admiral S. F. DUPONT, commanding; Commander C. R. P. RODGERS, Chief of Staff.

SCREW FRIGATE.—Wabash—Com. T. G. Corbin, one 150-pounder Parrott, one X-inch, one 30-pounder Parrott, forty-two IX-inch.

SCREW SLOOPS.—Pawnee—Com. G. B. Balch, eight IX-inch, one 100-pounder Parrott, one 50-pounder Dahlgren; Canandaigua—Capt. J. F. Green, two XI-inch pivot, one 150-pounder Parrott pivot, three 20-pounder Parrotts, two 12-pounder rifle howitzers, two 12-pounder S. B. howitzers; Housatonic—Capt. W. R. Taylor, one XI-inch, one 100-pounder Parrott, three 30-pounder Parrotts, four 32-pounders, one 12-pounder S. B. howitzer, one 12-pounder rifle howitzer; Mohawk—Com. A. K. Hughes, six 32-pounders, one 24-pounder S. B., one 12-pounder howitzer.

SIDEWHEEL STEAMER.—Powhatan—Capt. S. W. Godon, Capt. Charles Steedman, seven IX-inch, one 100-pounder Parrott pivot, one XI-inch pivot.

GUNBOATS.—Wissahickon—Lieut.-Com. J. L. Davis, one 150-pounder Parrott pivot, one 20-pounder Parrott pivot, two 24-pounder S. B. howitzers, one 12-pounder rifle howitzer; Seneca—Lieut.-Com. William Gibson, one XI-inch pivot, one 20-pounder Parrott pivot, two 24-pounder S. B. howitzers; Unadilla—Lieut.-Com. S. P. Quackenbush, one XI-inch pivot, one 20-pounder Parrott pivot, four 24-pounder S. B. howitzers, one 12-pounder S. B. howitzer; Marblehead—Lieut.-Com. R. W. Scott, one XI-inch pivot, one 20-pounder Parrott pivot, two 24-pounder S. B. howitzers; Ottawa—Lieut.-Com. W. D. Whiting, one XI-inch, one 20-pounder Parrott, two 24-pounder howitzers; Water Witch—Lieut.-Com. A. Pendergrast; Huron—Lieut.-Com. G. A. Stevers, one XI-inch pivot, one 20-pounder Parrott rifle, two 24-pounder S. B. howitzers.

DOUBLE-ENDERS.—Sebago—Com. J. C. Beaumont, one 100-pounder Parrott pivot, five IX-inch, two 24-pounder S. B. howitzers; Cimarron—Com. A. G. Drake, one 100-pounder Parrott, one IX-inch, two IX-inch pivot, four 24-pounder S. B. howitzers; Conemaugh—Com. Reed Werden, one 100-pounder Parrott pivot, four IX-inch, two 24-pounder S. B. howitzers, one XI-inch pivot; Paul Jones—Com. Charles Steedman; Com.

REPORTS, CORRESPONDENCE, DESPATCHES, ETC. lxvii

A. C. Rhind; Lieut.-Com. E. P. Williams, one 100-pounder Parrott pivot, one XI-inch pivot, four IX-inch, one 12-pounder S. B., light.

**PURCHASED STEAMERS.**—South Carolina—Com. J. J. Almy, one 30-pounder Parrott, one 24-pounder S. B. howitzer, four VIII-inch, two 32-pounders; Dawn—Act. Lieut. John S. Barnes, Act. Master James Brown, two 32-pounders, one 100-pounder Parrott, one 20-pounder Parrott, one 12-pounder howitzer; Mercedita—Com. H. S. Stellwagen; Quaker City—Com. J. M. Frailey; Commodore McDonough—Lieut.-Com. George Bacon, one IX-inch pivot, one 100-pounder Parrott, two 50-pounder Dahlgren rifles, two 24-pounder S. B. howitzers; Potomska—Act. V.-Lieut. William Budd, five guns; E. B. Hale—Act. Lieut. E. Brodhead, four 32-pounders, one 30-pounder Parrott pivot; Lodona—Com. E. R. Colhoun, one 100-pounder Parrott pivot, one 30-pounder Parrott pivot, one IX-inch, four 24-pounder S. B. howitzers; Norwich—Com. J. M. Duncan, four VIII-inch, one 30-pounder Parrott, one 12-pounder rifle howitzer; Wamsutta—Act. V.-Lieut. J. W. Kittredge, four 32-pounders, one 20-pounder Parrott, one 12-pounder rifle howitzer; Keystone State—Com. W. E. LeRoy, six VIII-inch, two 32-pounders, one 50-pounder Dahlgren, two 30-pounder Parrotts, two 12-pounder rifle howitzers; Madgie—Act. Master F. B. Meriam, one 30-pounder Parrott pivot, 1 20-pounder Parrott pivot, two 24-pounder S. B. howitzers, one 12-pounder S. B. howitzer; Isaac Smith—Act. Lieut. F. S. Conover; James Adger—Com. T. H. Patterson, one IX-inch, six 32-pounders, one 20-pounder Parrott, one 12-pounder S. B. howitzer; Augusta—Com. E. G. Parrott, six VIII-inch, one 100-pounder Parrott rifle, two 30-pounder Parrott rifles, one 12-pounder rifle howitzer; Flag—Com. J. H. Strong, four VIII-inch, one X-inch pivot, two 30-pounder Parrotts; Flambeau—Lieut.-Com. J. H. Upshur, one 30-pounder Parrott pivot, one 20-pounder Parrott pivot, two 12-pounder heavy howitzers; Stettin—Act. Master C. J. Van Alstine, one 30-pounder Parrott pivot, four 24-pounder S. B. howitzers; Uncas—Act. Master William Watson, four 32-pounders, one 20-pounder Parrott; Memphis—Lieut.-Com. P. G. Watmough, Act. Master C. A. Curtis, four 24-pounder S. B. howitzers, one 30-pounder Parrott rifle, two 12-pounder rifle howitzers.

**MONITORS** (one XV-inch, one XI-inch, each).—Patapsco—Com. D. Ammen; Passaic—Captain P. Drayton; Nahant—Com. John Downes; Montauk—Com. John L. Worden, Com. D. M. Fairfax; Nantucket—Com. D. M. Fairfax, Lieut.-Com. L. H. Newman, Com. J. C. Beaumont; Wechawken—Captain John Rodgers; Catskill—Com. George W. Rodgers.

**OTHER IRON-CLADS.**—Keokuk—Com. A. C. Rhind, two XI-inch S. B.; New Ironsides—Com. T. Turner, fourteen XI-inch, two 150-pounder Parrotts, two 50-pounder Dahlgrens.

**SAILING VESSELS** (barks).—Kingfisher—Act. Master J. C. Dutch, four VIII-inch; Brazilliera—Act. Master W. T. Gillespie, six 32-pounders;

Restless—Act. Master W. R. Browne; Midnight—Act. Master N. Kirby, one 20-pounder Parrott pivot, six 32-pounders; Fernandina—Act. Master E. Moses, six 32-pounders, one 20-pounder Parrott pivot, one 24-pounder S. B. howitzer.

MORTAR-SCHOONERS.—C. P. Williams—Act. Master S. N. Freeman, two 32-pounders, one 20-pounder Parrott rifle, one XIII-inch mortar; Para—Act. Master E. G. Furber, Act. Master Edward Ryan, two 32-pounders, one XIII-inch mortar; Norfolk Packet—Act. Ensign George W. Wood, two 32-pounders, one XIII-inch mortar, one 12-pounder rifle howitzer.

STORESHIPS.—Vermont—Com. William Reynolds, ten VIII-inch, eight 32-pounders; Valparaiso—Act. Master A. S. Gardner.

TUGS, TENDERS, AND DESPATCH-BOATS.—O. M. Pettit, Act. Ensign T. E. Baldwin, one 20-pounder Parrott, one 30-pounder Parrott; Rescue—Act. Ensign C. A. Blanchard, one 20-pounder Parrott, one 12-pounder rifle howitzer; Hope—Act. Master J. E. Rockwell, one 20-pounder Parrott pivot; Daffodil—Act. Master E. M. Baldwin, one 20-pounder Parrott rifle, one 20-pounder Dahlgren rifle; Dandelion—Act. Ensign William Barrymore, two guns; Columbine—Act. Master J. S. Dennis, Act. Ensign E. Daly, two 20-pounder Parrotts; G. W. Blunt—Act. Master J. R. Beers, one 12-pounder rifle howitzer, one 12-pounder S. B. howitzer; America—Act. Master J. Baker; Oleander—Act. Master J. S. Dennis, two 30-pounder Parrott pivots.

---

#### CHAPTER IV.

*Report of Brigadier-General George C. Strong, U. S. Army, commanding Brigade.*

MORRIS ISLAND, S. C., }  
July 10, 1863. }

GENERAL: Pursuant to instructions of yesterday from division headquarters, I embarked during the night in row-boats, at a point near the south-western extremity of Folly Island, all the infantry of my brigade, with the exception of six companies of the Forty-eighth regiment New York volunteers. Convoys by four howitzer-boats, supplied by the admiral, we proceeded, at 1 A. M. to-day, up Folly River and Folly Island Creek, and thence to a point in Lighthouse Inlet, one mile north-west from our masked batteries at the northern extremity of Folly Island. This point of the inlet was reached just before daybreak, and here we awaited the result of the bombardment of Morris Island commenced at 5 A. M. by our batteries. Lieutenant-Commander Bunce also opened fire from the howitzer-boats soon after upon the nearest of the enemy's works.

About 6 A. M. a line of skirmishers was seen approaching from our rear in the direction of Secessionville. The flotilla accordingly dropped down the inlet to a point more exposed to the fire of the Morris Island batteries, where we were vigorously assailed by them, with, however, the loss of but a single launch.

At about 7 A. M. I received from General Gillmore the signal to land and assault the enemy's works. Four companies of the Seventh Connecticut (the only companies of that regiment attached to my command), gallantly led by Lieutenant-Colonel Rodman, immediately landed at the extremity of the enemy's extensive series of rifle-pits opposite the left of our batteries. They were followed by the four companies of the Forty-eighth New York, Lieutenant-Colonel Green; the Ninth Maine regiment, Colonel Emery; the Third New Hampshire, Colonel Jackson; and the Seventy-sixth Pennsylvania, Colonel Strawbridge.

This, the main column, drove the enemy's infantry out of the rifle-pits, while the Sixth Connecticut regiment, Colonel Chatfield, having passed along the entire front of the enemy's line and effected a landing, was forming his command on the south-easterly point of the island, and alone constituted our right column of assault.

The two columns now moved forward under a lively discharge of shell, grape, and canister, converging toward the works nearest the southern extremity of the island, and thence along its commanding ridge and eastern coast, capturing successively the eight batteries, of one heavy gun each, occupying the commanding points of that ridge, besides two batteries, mounting, together, three X-inch sea-coast mortars. All this ordnance is in serviceable condition. As soon as the troops had disembarked the boats were sent across the inlet to the northern point of Folly Island, and brought thence the remainder of the Forty-eighth New York, the One-Hundredth New York, and the Seventh New Hampshire regiment (the two last named being a portion of General Vogdes's brigade), commanded, respectively, by Colonels Barton, Dandy, and Putnam. The promptness with which this reinforcement was effected deserves special mention.

We captured 150 prisoners (including 11 commissioned officers), 5 stand of colors, a considerable quantity of camp-equipage and ammunition, and several horses and mules.

We lost, of commissioned officers, 1 killed (the gallant Captain Lent, Forty-eighth New York volunteers) and 1 wounded; of non-commissioned officers and privates, 14 killed and 90 wounded.

The head of the column was halted within musket-range of Fort Wagner, situated near the northern extremity of the island, to which the enemy had retreated, and which was not to-day assaulted on account of the excessive heat of the weather and consequent fatigue of our troops.

I believe that I cannot too highly commend the coolness and courage



of my officers and men in the somewhat hazardous operation of landing in the face of the enemy.

Lieutenant-Commander R. M. Bunce, U. S. Navy, commanding the howitzer-boats, and Lieutenant A. S. McKenzie, U. S. Navy, in charge of the boats furnished from the fleet for our transportation, and the officers and men under their respective commands, did most gallant and valuable service.

Lieutenants Hatfield and Hickok of the Signal Corps maintained constant and perfect communication between my command and the head-quarters of the division and of the department.

The other officers of my staff, Captain William W. Harral, aide-de-camp; Major J. I. Plimpton, acting assistant inspector-general; Lieutenant Alvan H. Libby, acting assistant adjutant-general; Captain Edward F. Wyman, acting brigade commissary; Lieutenant Frank J. Magee, acting brigade quartermaster, and Surgeon Stephen F. Elliott, brigade surgeon, have my thanks for untiring and effective co-operation from the commencement of the embarkation and conspicuous gallantry during the action.

I am, general, very respectfully, your obedient servant,

GEO. C. STRONG,

*Brigadier-General, commanding Forces on Morris Island.*

Brigadier-General TRUMAN SEYMOUR,

*Commanding U. S. Forces on Morris and Folly Islands, S. C.*

HEAD-QUARTERS U. S. FORCES, }  
MORRIS ISLAND, S. C., July 11, 1863. }

GENERAL: Pursuant to instructions from department head-quarters, a column of assault was formed before daybreak this morning for an attack upon Fort Wagner. This column consisted of four companies of the Seventh Connecticut volunteers, the Seventy-sixth Pennsylvania, and the Ninth Maine regiments. The Third and Seventh New Hampshire regiments formed the reserve.

The assault was made at daybreak: the Seventh Connecticut deployed in the advance, supported by the Seventy-sixth Pennsylvania and Ninth Maine, in the order named, and each in close column of divisions.

The leading battalion had received orders to dash forward with a shout when the enemy should open fire, and the other battalions were directed to maintain their respective intervals.

These orders were most faithfully observed by Lieutenant-Colonel Rodman of the Seventh Connecticut, who led a portion of his command, under a very heavy fire of artillery and musketry, to the top of the parapet, where two of the enemy's gunners were bayoneted by his men.

But, unfortunately, when the enemy opened simultaneously along his whole line and within a range of 200 yards, the Seventy-sixth Pennsyl-

vania halted and lay down upon the ground. Though they remained in this position but a few moments, and afterward moved gallantly forward, some of them even to the ditch, that halt lost the battle, for the interval was lost and the Seventh, unsupported, were driven from the parapet. The whole column, including the Ninth Maine, which had reached the ditch on the left, gave way and retreated from the field. We lost in killed, wounded, and missing, 8 commissioned officers and 322 non-commissioned officers and privates. Lieutenant-Colonel Rodman, Seventh Connecticut volunteers, the bravest of the brave, is among the wounded.

The Seventy-sixth Pennsylvania regiment, heretofore bearing the reputation of a most gallant and thoroughly disciplined organization, will have another and early opportunity to efface the remembrance of their involuntary fault. The causes of their failure, and hence the failure of the assault, were first, the sudden, tremendous, and simultaneous fire which all encountered; and, second, the absence of their colonel, who was taken ill before the column was put in motion.

I am, general, very respectfully, your obedient servant,

GEO. C. STRONG,

*Brigadier-General, commanding.*

Brigadier-General TRUMAN SEYMOUR,

*Commanding U. S. Forces on Morris and Folly Islands, S. C.*

*Reports of Colonel R. F. Graham, commanding Morris Island,  
July 10th and 11th.*

HEAD-QUARTERS FORT JOHNSON, }  
July 18, 1863. }

CAPTAIN: I beg leave to submit the report of the engagement on Friday, the 10th instant, by which the Abolitionists gained possession of the works on Morris Island south of Battery Wagner.

I was aware that an attack was shortly to be made on Morris Island by the unmasking of extensive works on Little Folly Island on Thursday morning, and also by the arrival of four iron-clad monitors off the bar, which was reported to district head-quarters and reinforcements asked for.

On Friday, the 10th instant, the engagement began by the batteries on Little Folly Island opening with a terrific fire before sunrise on the works at the south end of Morris Island, and soon after by the iron-clads from the sea on the left, and several barges with howitzers in Lighthouse Creek on the right. The fire was gallantly replied to by the artillerists under the immediate command of Captain J. C. Mitchel. The infantry force was immediately formed and put in position to resist a landing at Oyster Point, and placed under the command of Major George W. McIver, Twenty-first South Carolina volunteers. This force consisted of the Twenty-first South Carolina volunteers, numbering about

400 men, and a detachment of Company D, First South Carolina regular Infantry [Third Artillery], numbering about 40 men, under the command of Captain C. T. Haskell, Jr.

About one hour and a half after the engagement commenced the enemy landed, under cover of their fire, at Oyster Point, between 2000 and 3000 strong, and a destructive fire was directed against them by our batteries. They were promptly met by the infantry force under Major McIver, and held in check until a like force was landed in front of the batteries under cover of the bank of the creek, the tide being low. At this time a portion of Nelson's battalion came up. I hurried them to the support of the batteries. They did not get in position, however, for the front line of our works was in the possession of the enemy, and one-half of the force under the command of Major McIver was either killed or wounded, and more than half of the officers. I then ordered the whole force to retire, which they did in order, firing as they retreated. When about halfway back to Battery Wagner the rest of Nelson's battalion came up. I had them formed in line of battle to cover the retreat. The iron monitors followed us along the channel, pouring into us a fire of shell and grape. When the exhausted and wounded had got sufficiently to the rear, I then ordered the whole to retire to Battery Wagner.

The Twenty-first South Carolina volunteers lost in killed, wounded, and missing 183. Captain Haskell's company lost 12. The artillery command lost 100.

Of the whole command, I must say that they fought bravely and well. Many individual acts of gallantry could be mentioned, but where all did well it would be invidious to report them. I cannot, however, fail to mention the gallant conduct of Captain W. E. Stoney, acting assistant adjutant-general to the command.

Very respectfully, your obedient servant,

R. F. GRAHAM,

*Colonel Twenty-first South Carolina volunteers, commanding.*

HEAD-QUARTERS FORT JOHNSON, }  
July 18, 1863. }

CAPTAIN: I beg leave to submit the following report of the assault made by the enemy on Battery Wagner on the morning of the 11th instant:

My command consisted of the Twenty-first South Carolina volunteers, about 200 men, under the command of Major McIver; Seventh South Carolina battalion, about 300 men, under the command of Major J. H. Rion; four companies First [volunteers] Georgia, Colonel C. H. Olmstead; four companies Twelfth Georgia battalion,<sup>1</sup> Lieutenant-Colonel

<sup>1</sup> This battalion was under command of Major G. M. Hanvey.

H. D. Capers; and three companies Eighteenth Georgia battalion, Major W. S. Basinger, the three detachments numbering about 500 men, all under the command of Colonel Olmstead; a detachment of Company D, First South Carolina [regular] Infantry [Third Artillery], numbering 20 men, under the command of Lieutenant J. Moultrie Horlbeck. The artillery force consisted of Companies E, I, and H, First South Carolina Artillery, numbering about 70 men, under the command of Captain Mitchel; the Gist Guard, Captain C. E. Chichester; the Mathewes Artillery, Captain J. R. Mathewes, numbering 100 men; all under the command of Lieutenant-Colonel Yates.

The whole garrison remained under arms during the night, and a picket force of 150 men under the command of Major Rion was sent in advance of the battery. Fearing an attack at daylight, I had the garrison aroused and put in position. The First Georgia, Eighteenth battalion, and detachment First South Carolina [regular] Infantry [Third Artillery] were placed on the left, the Twenty-first South Carolina volunteers in the centre, and the Twelfth Georgia battalion and Seventh South Carolina battalion on the right.

At the dawn of day the pickets warned us of the approach of the enemy. Three volleys were fired into the approaching enemy, and the whole picket force retired into the fort without loss. The enemy advanced in two columns, one on the beach and the other on the island. I allowed them to get within a short distance of the works, and gave the word "Fire!" A few of the front line reached the parapet. The rest fled in confusion, and when the smoke cleared away they were out of sight. Those who reached the parapet never returned.

I sent out a party, who returned with over 130 prisoners: 97 were left dead in front of the battery. We buried over 100. The burying-party was driven in by the sharpshooters of the enemy when they attempted to go beyond the mound in front of the battery. Many of their killed still lay beyond that point, so I cannot properly estimate their loss.

My loss was 1 officer killed and 5 privates, 1 officer wounded and 5 privates, all from the Georgia troops.

The whole garrison stood to their posts firmly, without flinching.

Very respectfully, your obedient servant,

R. F. GRAHAM,

*Colonel Twenty-first South Carolina volunteers, commanding.*

Captain W. F. NANCE,

*Assistant Adjutant-General.*

*Report of Colonel Harris, Chief Engineer, on Defenses of Morris Island.*

OFFICE CHIEF ENGINEER OF DEPARTMENT, }  
CHARLESTON, January 14, 1864. }

General G. T. BEAUREGARD,

*Comdg. Dept. S. C., Ga., and Fla., Charleston, S. C.:*

GENERAL: I have the honor to reply to the accompanying queries, addressed to Brigadier-General R. S. Ripley, commanding First Military District, by Lieutenant-Colonel A. Roman, assistant inspector-general, under date of December 12, 1863, which have been referred to me for my remarks:

1. Morris Island offers much greater natural advantages than Sullivan's Island against such a combined attack by land and sea as was made on the 10th of July last, the natural formation of the sandhills on the south end of Morris Island being much better calculated, without the aid of artificial defenses, to repel an attack across Lighthouse Inlet than those of Sullivan's Island across Breach Inlet. The sandhills on the south of Morris Island also offer much better cover for troops than the corresponding hills on the east of Sullivan's Island.

2. Two thousand infantry, in addition to the artillery requisite to serve the guns on Morris Island, could have repulsed the attack of the enemy on the 10th of July. Three thousand men of all arms I should have regarded as a full garrison for the island. Sullivan's Island, not having been threatened with a land-attack at that time, 1500 infantry, in addition to the cavalry and artillery on the island, would have been, I think, sufficient for the safety of the island. Thirty-five hundred men of all arms would have then constituted a full garrison for that island.

5. The only labor available for the works on the south end of Morris Island was details of soldiers from Colonel Graham's regiment—say of 100 to 150 men daily—which Captain Cheves reported were so steadily employed as “to prejudice their drill and other camp duties.”

6. It would have taken twelve months to have constructed such a work as Battery Marshall now is on the south end of Morris Island, with this force.

7. Orders were given for the erection of the detached batteries on the 10th of March, and the work was commenced two days thereafter.

8. The works that I contemplated constructing would, if finished, have permitted a reduction of 300 to 500 men in the forces necessary to have repelled the assault of the 10th of July.

I have the honor to be, general, very respectfully, your obedient servant,

D. B. HARRIS,

*Colonel and Chief Engineer of Department.*

[In the Appendix to the second volume of General Beauregard's *Military Operations* may be found a very full correspondence between Brigadier-General Ripley and himself on the subject of the descent of the Union troops on Morris Island, July 10, 1863. Some of the questions propounded by General Beauregard and answered by Brigadier-General Ripley are too important to be omitted. They are therefore extracted from their respective reports, and presented below in a form more direct and categorical than they appear in the full correspondence:]

QUESTION.

"4th. Even with works on the south end of Morris Island, and the small force then available for its defense, could not the enemy have landed, with the assistance of their gunboats and iron-clad fleet, a strong force on the beach north of Craig's Hill during the night, cut off the retreat of the troops south of it, and then crossed, almost unmolested, Little Folly Inlet?"

ANSWER.

"*To the 4th question:* In my opinion, it would have been possible, had the works at the south end of the island been completed, and with the small force at our disposal, for the enemy by a bold dash from their iron-clads and gunboats to have cut off the retreat of the troops south of Craig's Hill. Nevertheless, as it was intended that the whole beach should be swept with grape, and the landing is quite difficult, it is in my opinion doubtful whether he would have undertaken so hazardous an enterprise. He would probably have attempted to shell out the work at the south end directly; or, still more, changed his point of attack; or, what is still more probable, had we been fully prepared he never would have made it."

[General Ripley's answer to this question is a plain affirmative, as expressed in the first sentence. All the rest of the reply is irrelevant, while the assertion that "the landing is quite difficult" is not borne out by the facts of a smooth, gently-sloping beach and sandhills sufficient for ready cover.—J. J.]

QUESTION.

"8th. What was your force of infantry in the district, and how distributed?"

ANSWER.

"*To the 8th question:* My force of infantry was in all 2462 effective—1184 on James Island, 612 on Morris Island, and 204 on Sullivan's; and 462 in Charleston."

QUESTION.

"9th. Could a better disposition have been made of it?"

*Report on the Results of Explorations of Morris Island*

OFFICE OF THE ENGINEER OF DEPARTMENT,  
WASHINGTON, JANUARY 14, 1864.

General G. T. Bell, Major

of the Corps of Engineers, Fort Mifflin, Pa., U. S. A.

Reference is made to the report of Major G. T. Bell, accompanying queries, submitted to the Engineer of Department, U. S. A., by the commanding First Military District, Charleston, S. C., dated 10th August, 1863, and to the report of the Assistant Inspector-General, Charleston, S. C., dated 12th August, 1863, which have been referred to me for my remarks.

It is to be observed that Morris Island possesses a greater natural advantage than Sullivan's Island, inasmuch as it is a more extensive island, and sea as well as land, and the distance across the water, from the base of the sandhills on the south end of Morris Island being much better calculated, without the necessity of a long approach to the attack across Lighthouse Inlet and the shoals of Sullivan's Island across Lighthouse Inlet. The sandhills on the south end of Morris Island afford much better cover for troops than the sandhills on the east end of Sullivan's Island.

The only advantage in respect to the artillery requisite to secure the guns on Morris Island would have required the attack of the guns from the land. In the absence of all arms I should not have been able to attack the island. Sullivan's Island, not having been fortified with a garrison at that time, 1860 infantry, 1000 men, could have been landed on the island, would have been sufficient to hold the island. Thirty-five hundred men would have been constituted a full garrison for that island.

The only advantage in respect to the works on the south end of Morris Island was the position of the guns from Colonel Graham's regiment, and the fact that the guns were reported by Captain Chaves reported to be in good condition as to position their drill and other camp duties.

It would have taken five months to have constructed such a work as the works on the south end of Morris Island, with this

[In the Appendix to the second volume of General Beauregard's *Military Operations* may be found a very full correspondence between Brigadier-General Ripley and himself on the subject of the descent of the Union troops on Morris Island, July 10, 1863. Some of the questions propounded by General Beauregard and answered by Brigadier-General Ripley are too important to be omitted. They are therefore extracted from their respective reports, and presented below in a form more direct and categorical than they appear in the full correspondence:]

QUESTION.

"4th. Even with works on the south end of Morris Island, and the small force then available for its defense, could not the enemy have landed, with the assistance of their gunboats and iron-clad fleet, a strong force on the beach north of Craig's Hill during the night, cut off the retreat of the troops south of it, and then crossed, almost unopposed, Little Folly Inlet?"

ANSWER.

"To the 4th question: In my opinion, it would have been possible had the works at the south end of the island been completed, and with the small force at our disposal, for the enemy by a bold dash from their iron-clads and gunboats to have cut off the retreat of the troops south of Craig's Hill. Nevertheless, as it was intended that the whole beach should be swept with grape, and the landing is quite difficult, in my opinion doubtful whether he would have undertaken so hazardous an enterprise. He would probably have attempted to shell out the works at the south end directly; or, still more, changed the point of attack to what is still more probable, had we been fully prepared to have done so, he would have made it."

[General Ripley's answer to this question is a plain affirmation expressed in the first sentence. All the rest of the answer is a comment while the assertion that "the landing is quite difficult" is supported out by the facts of a smooth, gently-sloping beach and a narrow inlet for ready cover.—J. J.]

QUESTION

"8th. What was your force of infantry in the assault on Morris Island?"

ANSWER

"To the 8th question: My force of infantry was 1100 on James Island, 612 on Morris Island, and 462 in Charleston."

QUESTION

"9th. Could a battery of 100 guns be landed on Morris Island?"



## ANSWER.

"To the 9th question: I do not know that a better disposition could have been made; for had we concentrated on Morris Island the enemy would at once have turned to James Island. He might have gone to Sullivan's Island by way of Long Island, but, having a foothold on James, and that being the most vital approach to Charleston, could he have taken our extended lines by a *coup-de-main* he would have selected that route. The opportunity would have been given him had we reduced the small force of infantry on that island. Had I had the troops, I should have thrown 2500 men on Morris Island to meet this attack. These would have been about as many as could have been advantageously used, and the number is about the fullest strength the garrison has been increased to at any one time since the 10th of July. James Island, under the circumstances, ought—the enemy having a position on it—to have been watched by from 3000 to 5000 infantry, besides the cavalry and artillery. An estimate for defense must of course be made as against certain attacks, and while the enemy has transportation in abundance, with a powerful steam navy, both offensive and transport, ours being deficient in both respects, and not sufficient for current service; he having the option which route to choose, we are compelled to guard all at once to such an extent as will prevent a complete surprise of some one of them.

"These remarks will, I think, answer the tenth, eleventh, twelfth, and thirteenth interrogatories. In answer to the fourteenth, fifteenth, and sixteenth, I think had we decreased our force on James Island by any number sufficient to have given positive strength to any other point, and the enemy had chosen and acted with as much *éclat* as he did at the south end of Morris Island or at either of the two assaults on Battery Wagner, he could have penetrated our long, unguarded lines in a day, and obtained possession of the approaches to Charleston, which, if he chose to make use of them, would have at once cut off our communications with Morris Island and Fort Sumter. I consider it fortunate, under all circumstances, that, situated as we were, the enemy chose the Morris Island route."

## CHAPTER V.

*Sortie from Battery Wagner.—Report of Major James H. Rion,  
Seventh South Carolina Battalion.*

BATTERY WAGNER, }  
MORRIS ISLAND, July 15, 1863. }

CAPTAIN: In pursuance of orders from Brigadier-General Taliaferro, commanding on Morris Island, I advanced last night about 12 upon the enemy's line upon this island, having with me 150 men from the Fifty-

first North Carolina volunteers, Twelfth Georgia battalion, Eighteenth Georgia battalion, Twentieth South Carolina volunteers, and Seventh South Carolina battalion. When the line of skirmishers arrived within one hundred and fifty yards of the boat-house (three-quarters of a mile distant), the advanced picket of the enemy fired upon them. This advanced picket was at once driven in, and, upon my right wing advancing rapidly, it was fired into by men in a rifle-trench extending across the island at the boat-house, just on this side of the graveyard. This is three-quarters of a mile from this battery. We returned the fire from both wings (the left fifty yards in rear of right, *en échelon*), and advanced upon the trench, when the enemy retreated out of it. When the right was within ten or fifteen yards of the trench, a very heavy fire from about 1000 men was opened upon us from a line some one hundred yards in rear of the trench.

After examining the trench (a very strong rifle-pit extending from the beach to the marsh, two hundred and fifty yards), and finding that the line would not advance in face of the fire, which illuminated all the ground in front and was very heavy, I withdrew the line, bringing off the wounded we found and one of the enemy's advanced pickets, whom we had captured. Afterward we took another prisoner, whom I had sent through my lines when advancing against the rifle-trench.

Light pieces (about 12-pounders) were fired from Vinegar Hill, some three hundred yards in rear of the rifle-trench, and a very heavy gun was fired from Gregg's Hill, about two miles from this battery.

Upon finding that some men were missing, I returned with my command toward the enemy's position, and brought to the rear some more wounded, without being fired upon from the rifle-trench. Upon learning that one of the Seventh South Carolina battalion was subsequently discovered to be missing, I again returned with 20 men from that battalion, and found the wounded man near the trench, and brought him off, without receiving a shot from the rifle-trench, which evidently had been abandoned.

Our loss was 11 wounded (1 since dead) and 3 missing. Of the wounded, 1 was mortal, 2 were severe, and 8 slight.

The enemy's loss in killed and wounded, judging from the bodies I saw in the trench, must have been as many as 40. We also took, as ordered by the brigadier-general commanding, 2 prisoners.

This report is very hurried, and consequently disconnected. You will please, however, submit it for the consideration of the brigadier-general commanding.

Very respectfully, your obedient servant,

JAMES H. RION,

*Major Seventh South Carolina Battalion, comdy. Attacking Party.*

Captain W. E. STONEY,

*Assistant Adjutant-General.*

*Report of Brigadier-General Johnson Hagood, C. S. Army, commanding on James Island.*

HD-QRS. 1ST SUBDIVISION 1ST MIL. DIST. SOUTH CAROLINA, }  
 JAMES ISLAND, July 18, 1863. }

**CAPTAIN:** I have the honor to make the following report of the operations of the troops under my command on the 16th instant:

I had been instructed on the day previous to observe and report the possibility of offensive operations against the enemy in my front, and had reported two plans. The one which was limited to driving in their pickets on the left and making a reconnoissance of that part of their line, with the further object of capturing or destroying the part of their force nearest Grimball's, was the one approved.

The enemy occupied Battery Island and Legaré's plantation principally, and a part of Grimball's, while their gunboats lay in the Stono and Folly Rivers, giving a cross-fire in front of their position extending as far as our picket-line. General Colquitt was ordered with about 1400 infantry and a battery of artillery to cross the marsh dividing Legaré's plantation from Grimball's at the causeway nearest Secessionville, drive the enemy as far as the lower causeway (nearest Stono), rapidly recross the marsh at that point by a flank movement, and cut off and capture the force encamped at Grimball's. Colonel Way, Fifty-fourth Georgia, with about 800 infantry, was directed to follow, *en echelon*, on the Grimball side of the marsh the advance of General Colquitt and co-operate with him. A reserve of one section of artillery, supported by a company of infantry and a squadron of cavalry, under Lieutenant-Colonel Jeffords, Fifth South Carolina Cavalry, was held in hand near Rivers's house. On the right, a battery of four rifled 12-pounders and one of four Napoleons, under Lieutenant-Colonel Kemper, supported by Colonel Radcliffe with about 400 infantry, were ordered to engage the gunboats lying highest up the Stono.

The troops moved upon the enemy in the gray of the morning, becoming immediately engaged, and the whole enterprise was carried out as planned. The force at Grimball's, however, was smaller than was anticipated, and by retreating across to Battery Island as soon as Colquitt's firing was heard, managed to save themselves before he could get into position to intercept them. Colonel Kemper engaged the Pawnee and another gunboat at two hundred and fifty yards, and after some ten rounds drove them down the river beyond his range. The reserve artillery was not brought into action. The cavalry did good service in sweeping up fugitives. The troops were under fire one hour and a half, and behaved well. This fire was chiefly shell from gunboats and shell and case from a field-battery. The enemy's infantry fought badly. They were chiefly colored troops, and 14 of them were captured. These be-

longed to the Fifty-fourth Massachusetts. About 30 of the enemy were killed upon the field.

I beg leave to refer to accompanying reports of subordinate commanders for full details.

The enemy were supposed not to have been above 2000 infantry and one battery of artillery. Upon the following night they evacuated James and Battery Islands, leaving behind them arms and stores, of which a full return will be made.

Our casualties were 3 killed, 12 wounded, and 3 missing.

Colonel William Bull and Captain A. N. T. Beauregard of the staff of General Beauregard, and Captain B. H. Read of General Ripley's staff, reported to me for duty upon the occasion, and, together with my own staff, rendered efficient service.

I am, captain, your obedient servant,

JOHNSON HAGOOD,

*Brigadier-General, commanding.*

Captain W. F. NANCE,

*Assistant Adjutant-General.*

*Return of Casualties in the Union Forces engaged near Grimball's Landing, James Island, S. C., July 16, 1863.*

[Compiled from nominal list of casualties, returns, etc.]

Command.	Killed.		Wounded.		Captured or missing.		Aggregate.
	Officers.	Enlisted men.	Officers.	Enlisted men.	Officers.	Enlisted men.	
1st Connecticut Battery . . . . .	..	..	..	1	..	..	1
1st Massachusetts (cavalry detachment) . . . . .	..	..	..	1	..	..	1
24th Massachusetts Infantry . . . . .	..	..	..	1	..	..	1
54th Massachusetts Infantry (colored) . . . . .	..	14	..	17	..	12	43
Total . . . . .	..	14	..	20	..	12	46

*Report of Brigadier-General T. Seymour on Assault of Battery Wagner on 18th of July.*

... My instructions from Brigadier-General Gillmore were to open fire at daybreak, but an excessively heavy rain had fallen during the preceding night, so flooding the works and deranging our affairs generally that it could not be commenced until after nine o'clock. A

deliberate experimental fire was first directed, which gradually became as rapid as accuracy would allow. The monitors, the Ironsides, and other vessels moved up, and from about noon until nightfall the fort was subjected to such a weight of artillery as had probably never before been turned upon a single point. The garrison remained closely under shelter, returning only an occasional gun, and there was no evidence, from close personal observation, that any material damage had been done to the artillery of the fort. Our own guns were, in fact, too far distant for accurate dismounting fire, and a portion of the right battery was so far useless, from improper location, that its gunners could not even see the object at which they fired. Nevertheless, it was presumed that under such intense fire some demoralization must have been effected within.

About an hour before sunset I received instructions from Brigadier-General Gillmore to arrange for an assault. It was suggested to me that the brigade of General Strong would suffice, but it was finally understood that all the force of my command should be held ready for the work. The division was accordingly formed on the beach and moved to the front. It consisted of three fine brigades.

The First, under Brigadier-General Strong, was composed of the Forty-eighth New York, Colonel Barton; Seventy-sixth Pennsylvania, Captain J. S. Littell; Third New Hampshire, Colonel Jackson; Sixth Connecticut, Colonel Chatfield; Ninth Maine, Colonel Emery; and, temporarily, the Fifty-fourth Massachusetts, Colonel Shaw.

The Second brigade, under Colonel Putnam, Seventh New Hampshire, consisted of the Seventh New Hampshire, Lieutenant-Colonel Abbott; One Hundredth New York, Colonel Dandy; Sixty-second Ohio, Colonel Pond; and Sixty-seventh Ohio, Colonel Voris.

The Third brigade was commanded by Brigadier-General Stevenson, and consisted of four excellent regiments.

General Strong was to take the advance. I had informed him that he should be promptly supported if it were necessary. Colonel Putnam was instructed to keep his brigade ready for following up the First, while General Stevenson was held in reserve.

That moment was chosen for moving forward when the dusk of the evening still permitted the troops to see plainly the way, already well known to the First and Second brigades, but was yet sufficiently indistinct to prevent accurate firing by the enemy. Our troops were to use the bayonet alone.

Half the ground to be passed over was undulating from small sand-hills, affording some shelter, but not so rough as to prevent free movement of troops. That part of it next the fort was quite smooth and unobstructed to the very ditch.

The Fifty-fourth Massachusetts, a colored regiment of excellent character, well officered, with full ranks, and that had conducted itself

commendably a few days previously on James Island, was placed in front.

Brigade commanders were advised to form in column of deployed regiments. The Fifty-fourth Massachusetts only, being too large to admit this development, was in two lines.

Once in advance of our batteries, a few encouraging words were given to the men, and the First brigade launched forward. It had not moved far before the fort, liberated somewhat from the pressure of our fire, opened with rapid discharges of grape and canister, and its parapet was lit by a living line of musketry. More than half the distance was well passed when, present myself with the column, I saw that to overcome such resistance overpowering force must be employed. Major Plimpton, Third New Hampshire, my assistant inspector-general, was sent to order the Second brigade forward at once. To my surprise, this officer returned from Colonel Putnam, stating that he positively refused to move, with the explanation from Colonel Putnam that he had received orders from General Gillmore to remain where he was. At this moment the wounded and many unhurt also were coming thickly from the front along the beach. General Stroug had urged his command on with great spirit and gallantry, but his losses had been so severe that his regiments were much shaken, and the consequent confusion was much heightened by the yielding of the leading regiment, large portions of which fell harshly upon those in their rear. Fragments of each regiment, however—brave men, bravely led—went eagerly over the ditch, mounted the parapet, and struggled with the foe inside. But these efforts were too feeble to affect the contest materially. Prompt support was not at hand, and the First brigade, as a mass, had already retired, although detached portions, principally from the Forty-eighth New York and Sixth Connecticut, with the colors of those regiments, still clung to the fort.

After a painful and unnecessary interval, Colonel Putnam, knowing that I had expected him to come up closely and to take an energetic share in the assault, had without further orders moved his command forward. This gallant brigade went steadily on, in spite of much loss and not a little falling to the rear, and, clearing rapidly the intervening space, came to the aid of the noble fellows still battling on the parapet. By a combined and determined rush over the south-east angle of the fort, the enemy was driven from that portion of the work. Some hundred men were now inside, with Colonel Putnam at their head. The bastion-like space between the bombproof and the parapet was fully in our possession. Some of our officers and men mounted the bombproof itself, which completely commanded the interior of the fort. Strong efforts were made by the enemy to drive our brave fellows out, but unsuccessfully, and rebel officers and men were captured and sent to the rear. For more than an hour this position was maintained by Colonel Putnam, assisted by Colonel Dandy, One Hundredth New York; Major

Butler, Sixty-seventh Ohio; Major Coan, Forty-eighth New York; Captain Klein, Sixth Connecticut, and a number of other very brave and devoted officers. And now Colonel Putnam, while waiting patiently for expected succor and urging his men to maintain the advantage that had been gained, was shot dead on the parapet—as brave a soldier, as courteous a gentleman, as true a man, as ever walked beneath the Stars and Stripes.

General Strong had long since been wounded. Colonel Chatfield, Sixth Connecticut; Colonel Barton, Forty-eighth New York; and Colonel Shaw, Fifty-fourth Massachusetts, had fallen, after the most gallant efforts, in front of their commands; and during the advance of the Second brigade I had been struck by a grape-shot and was compelled to retire. But I had previously sent Major Plimpton to order up General Stevenson's brigade, which order was reiterated after my being hurt. You were sent by General Gillmore to take further command, and the Third brigade had no part in the attack.

Finally despairing, after long waiting, of further assistance, the senior officers at the fort withdrew our men (with exception of about 100, who could not be reached, and who were soon after captured), and what had been so dearly bought was abandoned to the enemy.

And the failure must be ascribed solely to the unfortunate delay that hindered Colonel Putnam from moving promptly in obedience to my orders, and to his not being supported after he had essentially succeeded in the assault.

Unsuccessful as we were, the highest praise is due to those noble men who did their full duty that night. Who can forget, while courage and generosity are admired by man, that glorious soldier Strong, or the heroic Putnam, or Chatfield the beloved, or Shaw, faithful and devoted unto death? Many more than these deserve lasting record, of the rank and file as well as of officers, but the loss of those of high command, and the scattering of the many wounded who were prominent actors in this scene, with the difficulty of procuring sufficient information otherwise, compel me to but a meagre outline. On every inch of the sands in front of Fort Wagner will be for ever traced in undying glory the story of the determination and courage of these men.

I cannot close without thanking Lieutenant-Colonel Jackson and Captain Langdon, First Artillery, with the other officers of that arm, for their efficient and valuable services during the day. Major Plimpton, Third New Hampshire, rendered me the most energetic assistance. Lieutenant Stevens, Sixth Connecticut, one of my aides, a young man of great promise, was killed at my side. To Captain Peter R. Chadwick, assistant adjutant-general, Lieutenant Charles N. Jackson and Lieutenant Holt, my aides, my thanks are also due for good conduct and prompt action at all times. Nor can I fail to call the attention of General Gillmore to the merits of Lieutenant Michie, U. S. Engineers,

who labored early and late, with untiring zeal, in the preparations for this assault.

Such reports as I have been able to obtain are herewith enclosed.

And I am, general, respectfully, your obedient servant.

T. SEYMOUR,

*Brigadier-General U. S. Volunteers.*

Brigadier-General J. W. TURNER,

*Chief of Staff, Department of the South.*

*Report of Brigadier-General William B. Taliaferro, C. S. Army, commanding on Morris Island, July 14th-19th and 22d-26th, and afterward on James Island.*

JULY 21, 1863.

CAPTAIN: I have the honor to report, for the information of the brigadier-general commanding the District of South Carolina, the operations of the troops of my command on Morris Island during the week commencing Monday, 13th instant, and particularly the occurrences of Saturday, the 18th instant, which terminated in a most decisive and overwhelming repulse of the enemy.

On Monday, the 13th instant, I made such an inspection of parts of the island as the limited means at my disposal offered, and on Tuesday morning relieved Colonel Graham of the command of the troops, including the garrisons of Forts Wagner and Gregg. I found that the Abolitionists occupied the island in force from the southern part to Gregg's Hill, upon which they were already erecting batteries, and had constructed a signal-station—that they had thrown forward their skirmishers to a point indicated by a single palmetto tree (one mile and a quarter to their front and about three-quarters of a mile from Fort Wagner), at which last post the undulating and successive ranges of sandhills shielded them and their operations from our view. In the course of the morning their riflemen gave us some annoyance, and during the day the wooden vessels of their fleet, aided by one turreted iron-clad, attacked our works, throwing some 300 heavy shell and shot. I determined to make a slight reconnoissance at night to feel the enemy and to add to the confidence of the garrison, and ordered a party, consisting of 150 men from various commands, under Major Rion of Nelson's South Carolina battalion, to push forward, drive in the enemy's pickets, and feel its way until it encountered a heavy supporting force. This duty was gallantly and well performed. Major Rion pushed the pickets and the first reserve back upon a reserve brigade in such disorder that the latter fired upon their retreating companions, inflicting a heavy loss in addition to the punishment already inflicted by Major Rion. I established rifle-pits some 200 yards outside the work (the nearest practicable point), and made such dispositions for holding the



post against assault (by assigning each command its particular position, etc.) as were necessary.

On Wednesday, Thursday, and Friday the bombardment was kept up from the fleet from ten until five [o'clock] each day, the average number of projectiles thrown at the work being 300 daily, the casualties being few and the damage to the fort inappreciable, our work having been directed up to this time not in repairs, but to improvements at Forts Wagner and Gregg. During these three days the enemy, under cover of the sandhills, erected batteries on land, the nearest being about three-quarters of a mile off, and others extending from Gregg's Hill to the left, and distant about one and three-quarter miles from Fort Wagner. These batteries were gradually unmasked, and were, with the exception of the first, entirely without range of our guns.

On Saturday, the 18th instant, at 8.15 A. M., the enemy, having disclosed his land-batteries, brought up to their support his entire fleet, consisting of the Ironsides flagship, five monitors, and a large number of wooden steam-gunships. With this immense circle by land and sea he poured for eleven hours, without cessation or intermission, a storm of shot and shell upon Fort Wagner which is perhaps unequalled in history. My estimate is that not less than 9000 solid shot and shell of all sizes, from XV-inch downward, were hurled during this period at the work. The estimate of others is very much greater.

The garrison of the fort on this day consisted of the Charleston battalion, Lieutenant-Colonel P. C. Gaillard, whose position extended from the sally-port in Lighthouse Inlet Creek on the right, to the left until it rested on Colonel H. McKethan's regiment, Fifty-first North Carolina troops, which extended to the gun-chamber opposite the bombproof door, at which point, and extending along the face of the work to the left to the sally-port next Fort Gregg, the Thirty-first North Carolina troops, Lieutenant-Colonel C. W. Knight, occupied the work. These positions for the infantry were verified by frequent inspections, and the several commands were required to sleep in position, and each man was instructed as to the exact point which he should occupy, and which in any moment of confusion he would be required to gain and hold. In addition to this, a small portion of the Thirty-first North Carolina troops were held as a reserve in the parade, and a part occupied the parapet just to the right of the sally-port.

On the outside of the fort two companies of the Charleston battalion held the sandhills along the beach and the face extending from the sally-port to the sea-beach. The artillerists occupied the several gun-chambers, and two light field-pieces were placed in battery outside of the fort on the traverse near the sally-port. The artillery command consisted of Captains W. T. Tatom and Warren Adams, First South Carolina [regular] Infantry [Third Artillery]; J. T. Buckner and W. J. Dixon, Sixty-third Georgia Heavy Artillery, and Captain

De Pass, commanding light artillery, all under the general command of Lieutenant-Colonel J. C. Simkins, chief of artillery.

The infantry, excepting the Charleston battalion, and the artillery, excepting the gun detachments, were placed, shortly after the shelling commenced, under cover of the bombproofs. The first-named battalion, with a heroic intrepidity never surpassed, animated by the splendid example of their field officers (Lieutenant-Colonel Gaillard and Major David Ramsay), had no protection except such as the parapet afforded them, yet maintained their position without flinching during the entire day. The 10-inch gun was fired at intervals of ten to fifteen minutes against the iron-clads, and the heavy guns on the land face whenever the working-parties or cannoneers of the enemy on the land showed themselves within range. The mortar, in charge of Captain Tatom, was fired every half hour.

The casualties during the day of the bombardment did not exceed 8 killed and 20 wounded.

About two o'clock the flag halyards were cut and the Confederate flag blew over into the fort. Instantly Major Ramsay, Charleston battalion, Lieutenant William E. Reddick, Sixty-third Georgia [Artillery], Sergeant Shelton and Private Flinn, Charleston battalion, sprang forward and replaced it on the ramparts, while at the same time Captain R. H. Barnwell of the Engineers dashed out, seized a battle-flag, and erected it by the side of the garrison flag. This flag was subsequently shot away, and replaced by Private Gilliland, Charleston battalion.

As night approached, the increased severity of the bombardment plainly indicated that an assault would be made, and orders were issued to the commands to prepare to man the ramparts. At 7.45 o'clock the lines of the enemy were seen advancing, and the bombardment slackened to an occasional shell from the ships and the land-batteries. As the enemy advanced they were met by a shower of grape and canister from our guns, and a terrible fire of musketry from the Charleston battalion and the Fifty-first North Carolina. These two commands gallantly maintained their position, and drove the enemy back quickly from their front with immense slaughter.

In the mean time, on the left of the work the Thirty-first North Carolina could not be induced to occupy their position, and ingloriously deserted the ramparts, when, no resistance being offered at this point, the advance of the enemy, pushing forward, entered the ditch and ascended the work at the extreme left salient of the land face, and occupied it. I at once directed Lieutenant-Colonel Gaillard to keep up a severe enfilading fire to his left, and directed the field-pieces on the left of the fort outside of the sally-port to direct their fire to the right, so as to sweep the ditch and exterior slope of that part of the work thus occupied, and thus, at the same time, prevented the enemy from being supported at that point and cut off all hope of his escape.

The main body of the enemy, after a brief attempt to pass over the field of fire, retreated under the fire of our artillery and the shells of Fort Sumter, and must have suffered heavily as long as they were within the range of our guns.

Colonel Harris of the Engineers, to whose skill I am much indebted, and whose coolness and gallantry were most conspicuous during the previous day, placed a howitzer on the right of the fort outside the beach and co-operated with the guns on the left.

Thinking it advisable to dislodge the enemy at once, before they had time to communicate their temporary success, I called for volunteers to dislodge them. This call was promptly met by Major J. R. McDonald, Fifty-first North Carolina troops, and by Captain Ryan, Charleston battalion. I selected Captain Ryan's company, and directed them to charge the enemy in the salient. This work they advanced to with great spirit, but, unfortunately, Captain Ryan was killed at the moment of the advance, and his men hesitated and the opportunity was lost. Whenever the enemy showed themselves a sharp fire was kept up upon them by the Fifty-first North Carolina, and after considerable injury thus inflicted, a party of the Thirty-second Georgia regiment having been sent along the parapet to the left and on the top of the magazine to approach their rear, they surrendered. In front of the fort the scene of carnage is indescribable. The repulse was overwhelming, and the loss to the enemy could not have been less than 2000, in killed, wounded, and prisoners—perhaps much more.

Our loss I estimate at 50 killed and 150 wounded, but will forward an exact return.

As to the damage done to the work and guns, I have the honor to refer you to the reports of the engineer officer and chief of artillery, which will be forwarded. I will remark this: While the injury done to the work is considerable, it is much less than could have been expected, and the damage to the guns, it is hoped, may be repaired in a short time.

In conclusion, . . . I am proud to bear testimony to the efficiency and gallantry of the other troops. Colonel H. McKethan's regiment, Fifty-first North Carolina troops, redeemed the reputation of the Thirty-first regiment. They gallantly sought their position under a heavy shelling, and maintained it during the action. Colonel McKethan, Lieutenant-Colonel C. B. Hobson, and Major McDonald are the field officers of this regiment, and deserve special mention.

The Charleston battalion distinguished themselves not only by their gallantry, but by their discipline and the cool performance of their duty and obedience to orders under the excitement and confusion always incident to a night attack.

Lieutenant-Colonel Gaillard and the brave Major Ramsay (who, I regret to say, was severely wounded) deserve the highest expression

of commendation for their conduct during the bombardment and the assault.

The artillery behaved throughout the day with remarkable courage. Lieutenant-Colonel Simkins had a most severe duty to perform during the day in directing the operations of the artillery. This, unflinchingly and admirably, he performed, and after the enemy's heavy guns had ceased he mounted the parapet and encouraged the infantry. There, on the ramparts in the front, this admirable soldier and accomplished gentleman sealed his devotion to our cause by an early but most heroic death.

Captains Buckner and Dixon, Sixty-third Georgia, and Captain Adams, First South Carolina Infantry [Third Artillery], deserve especial mention; but I desire to bring most conspicuously to the notice of the brigadier-general commanding the name of Lieutenant J. H. Powe, whose coolness, skill, and gallantry were unsurpassed. I regret to say he was severely wounded.

I would also especially mention Lieutenant T. D. Waties, commanding the field-pieces on the left of the work, who was conspicuous for his gallantry and who was severely wounded; and the skill, coolness, and gallantry of Captain DePass, who assumed command of his pieces after his fall. These pieces rendered most important service.

I have doubtless omitted the names of many officers whose gallantry should be recorded, and shall in a subsequent report endeavor to do justice to all.

I must, in conclusion, mention the good conduct of Sergeant John R. Williams of Lieutenant Powe's company, and Corporal Conneway of Twenty-second Georgia battalion, who greatly distinguished themselves.

To the officers of my personal staff I am under obligations.

I lament to record the death of the gallant Captain P. H. Waring, acting aide-de-camp, and the wounding of Captain H. D. D. Twiggs, assistant inspector-general, and Captain W. E. Stoney, aide-de-camp, who were stricken down, nobly discharging their duty.

To Captain W. T. Taliaferro, assistant adjutant-general; Lieutenants E. Mazyck and H. C. Cunningham, ordnance officers, and Richard K. Meade, aide-de-camp, and to Surgeon J. C. Habersham, Major E. L. Holcombe, and Captain Thomas A. Burke, I tender my thanks for their aid, etc. during the course of the week.

I would especially mention Captain R. H. Barnwell of the Engineers.

The commands of Colonel C. H. Olmstead, Lieutenant-Colonel H. D. Capers, Major G. M. Hanvey, and Major W. S. Bassinger; of Lieutenant-Colonel P. H. Nelson and Lieutenant-Colonel O. M. Dantzler; and the artillery, under the admirable management of Lieutenant-Colonel Joseph A. Yates, with such officers as Captains J. R. Mathewes and

C. E. Chichester, deserve great credit for their bravery and zeal in the early part of the week.

I have the honor to be, very respectfully, your obedient servant,

WM. B. TALIAFERRO,

*Brigadier-General.*

Captain W. F. NANCE,

*Assistant Adjutant-General.*

*Report of Lieutenant-Colonel P. C. Gaillard, Charleston Battalion.*

CHARLESTON, S. C., July 20, 1863.

CAPTAIN: I have the honor to report that under orders from district head-quarters I reported for duty at Battery Wagner on Wednesday evening, the 15th instant, with five companies of my battalion. I have no remarks to make upon any of the occurrences of the garrison, so far as my command is concerned, until Saturday, the 18th.

On that day the enemy commenced between 7 and 8 A. M. a heavy bombardment from their fleet in the channel and from the land-batteries erected by them across Morris Island. The bombardment was kept up unremittingly until between 7 and 8 P. M. It may be proper here to state that for two or three hours in the afternoon it was most furious in its character. My command was exposed to its fury the whole day, never having left its position, and it is with pride I say it was not demoralized in consequence of its exposure. Soon after dusk a violent assault was made upon the garrison by a strong force of infantry, which was repulsed by the garrison. Two of my companies (A and B) had been detached from my command, and posted outside the garrison near the sally-port at the north-east portion of the works. Of the operations of these two companies I cannot speak, as I was posted at the south-west portion of the work and remote from their position.

I herewith submit report from Captain Blake, who commanded. The three companies (C, D, and F) under my immediate command met the infantry assault with great coolness and deliberation. This assault was repulsed in a short time, when I directed my men to cease firing; nor was it requisite to open fire with them again. Soon after I ceased firing Brigadier-General Taliaferro in person called upon me for a portion of my command to occupy one of the batteries on the sea face, which was then occupied by the enemy. Major David Ramsay was leading this detachment, when it was fired into, as is supposed, by some of our troops, wounding the major and several others, and killing two men.

My officers and men behaved with admirable coolness throughout the whole affair, and it is impossible to particularize when all behaved well. I cannot omit, however, to mention the gallant bearing of Captain W. H. Ryan of Company C, who fell while leading a charge upon the battery occupied by the enemy.

I would also state that Sergeant William Shelton of Company C and Private John Flynn of Company F tied the garrison flag to a temporary staff and set it up on the parapet when the flag fell from the cutting of the halyards, and this, too, under a severe fire.

I would also mention the conduct of Private A. Gilliland of Company D, who at a later hour and under a severe fire set up a battle-flag which had been raised upon the parapet when the flag fell, and which was thrown down by the explosion of a shell in its vicinity.

Inclosed I submit a list of casualties.

Very respectfully, your obedient servant,

P. C. GAILLARD,

*Lieutenant-Colonel, commanding.*

Captain W. T. TALIAFERRO,

*Assistant Adjutant-General.*

[AUTHOR'S NOTE.

It has been mentioned in a note (page 105) that Lieutenant James Campbell, Company F, of the Charleston battalion, was made prisoner in this assault. When General Taliaferro, commanding in Battery Wagner, first discovered the enemy in the salient, it was Lieutenant Campbell who volunteered alone to reconnoitre and report the situation. Moving boldly along the ridge of the main bombproof, he soon overheard the men of the enemy talking in the gun-pit below him, and next on the north to the salient itself. Emboldened still more by the expressions of alarm and demoralization on the part of the invaders, who realized that they were wellnigh cut off, he ordered them to surrender, but paid dearly for his venture when they, discovering him to be alone, instantly turned upon him and passed him under heavy fire to their rear. This officer had been distinguished for the same fearless conduct at Secessionville the year before.]

*Report of Commander Balch.*

UNITED STATES STEAMER PAWNEE, }  
STONO RIVER, S. C., July 16, 1863. }

SIR: I have the honor to report that at 4.40 A. M., the Pawnee and Marblehead being at anchor near Fort Grimball, the enemy opened on us hotly from batteries distant about 600 yards, the first shot striking us, and the fire admirably given by the enemy. The position of the Pawnee was such that we could not get our guns to bear; and, seeing that we were powerless to inflict injury upon the enemy in that position, I deemed it prudent to drop down the river, where I could bring my guns to bear; this I did, and directed the Marblehead to do likewise. We were at anchor in position where we could reach the enemy, and

this ship, the Huron, and the Marblehead kept up a brisk fire on the enemy; and, soon, by reference to the signals made by General Terry, we were telegraphed to cease firing, the enemy having retreated.

The Pawnee was struck thirty-three times in the hull, three times in the smokestack, three boats damaged by shot, and some six shots in the rigging. The chain-cable which I had put on the outside, I am happy to state, saved us from injury to our boilers.

The casualties are, as reported by the surgeon, W. T. Hord, as follows, and, considering the excessively hot fire, it is cause of great surprise that there should have been no more: viz. John W. Philip, lieutenant U. S. N., slightly wounded; James P. Lindsay, acting master, U. S. N., slightly wounded; James Madon, boatswain's mate, U. S. N., slightly wounded; John B. Patterson, landsman, mortally wounded.

My officers and men behaved in the coolest manner, and I was aided and admirably supported by Lieutenant-Commander Scott of the Marblehead, and as soon as the Huron could she opened handsomely.

Very respectfully, your obedient servant,

GEORGE B. BALCH,

*Commander, and Senior Officer present.*

Rear-Admiral J. A. DAHLGREN,

*Commanding S. A. B. Squadron.*

---

CHAPTER VI.

*Brigadier-General Q. A. Gillmore reports the Demolition of Fort Sumter.*

HEAD-QUARTERS DEPARTMENT OF THE SOUTH, }  
MORRIS ISLAND, S. C., August 24, 1863. }

Major-General H. W. HALLECK,

*General-in-Chief U. S. Army, Washington, D. C.*

SIR: I have the honor to report the practical demolition of Fort Sumter as the result of our seven days' bombardment of that work, during two days of which a powerful north-easterly storm most seriously diminished the accuracy and effectiveness of our fire.

Fort Sumter is to-day a shapeless and harmless mass of ruins. My chief of artillery, Colonel J. W. Turner, reports its destruction so far complete that it is "no longer of any avail in the defense of Charleston." He also says that "by a longer fire it could be made more completely a ruin and a mass of broken machinery, but could scarcely be more powerless for the defense of the harbor."

My breaching-batteries were located at a distance varying between 3330 and 4240 yards from the work, and now remain as efficient as ever. I deem it unnecessary to continue their fire at present upon the ruins

of Sumter. I have also, at great labor and under a heavy fire from James Island, established batteries on my left within effective range of the heart of Charleston City, and have opened with them, after giving General Beauregard due notice of my intention to do so. My notification to General Beauregard, his reply thereto with the threat of retaliation, and my rejoinder, have been transmitted to army head-quarters. The projectiles from my batteries entered the city of Charleston, and General Beauregard himself designates them as the most destructive missiles ever used in war.

Very respectfully, etc.,  
 Q. A. GILLMORE,  
*Brigadier-General, commanding.*

*Correspondence between Brigadier-General Gillmore and Rear-Admiral Dahlgren.*

FLAG-STEAMER DINSMORE, }  
 OFF MORRIS ISLAND, July 20, 1863. }

DEAR SIR: I hope your efforts will be more successful next time. . . . When ready I will support you with the vessels, and hope to quell the fire of the work as before, and drive the garrison to shelter. When the assault takes place in front, I propose to land from boats one of your best regiments to assault the angle rearward and toward the water. I would also suggest a picked column of three or four hundred men to attack the angle rearward and landward, passing up the rivulet that enters Vincent's Creek; for this I will also endeavor to furnish boats. Thus assaulted, and the enemy kept under shelter to the last moment, it seems to me that the gallantry of our troops cannot fail to carry them into the work.

Very respectfully, your obedient servant,  
 J. A. DAHLGREN,  
*Rear-Admiral, commanding.*

Brigadier-General Q. A. GILLMORE,  
*Commanding Department of the South, Morris Island.*

HEAD-QUARTERS DEPARTMENT OF THE SOUTH, }  
 MORRIS ISLAND, S. C., July 20, 1863. }

DEAR SIR: I am in receipt of your communication of this date suggesting a method of attacking Fort Wagner. I am pleased with the project. I had already determined to advance my batteries, and shall commence doing so to-night. I also like your plan of assaulting the work, although I would much prefer making two columns of attack only—one in front along the beach, and the other in rear, landing on the east side of Morris Island.

It involves, however, the consumption of men, in which this army has



already been a very severe sufferer. I began here with the minimum force deemed safe for any offensive operations. Of that force I have lost thirty-three per centum in killed, wounded, missing, and sick. My actual loss in killed, wounded, and prisoners will not fall far short of twelve hundred men. As many more are laid up by sudden sickness occasioned by excessive fatigue-duty.

With this more than triple decimation of my active available command, I hesitated to incur any further immediate loss in the absence of powerful reasons to the contrary.

If the navy can furnish sailors and marines for one of the columns of attack, I will supply the other or others, and a combined attack can be made on the work. . . . Should you desire to confer with me on this project I will come and see you.

I have the honor to be, admiral, very respectfully, your obedient servant,

Q. A. GILLMORE,

*Brigadier-General, commanding.*

Rear-Admiral J. A. DAHLGREN, *commanding.*

HEAD-QUARTERS DEPARTMENT OF THE SOUTH, }  
MORRIS ISLAND, S. C., August 3, 1863. }

Rear-Admiral DAHLGREN,

*Commanding S. A. B. Squadron:*

ADMIRAL: I am more and more convinced that we can practically invest this island, or at least keep all steamers away from Cumming's Point. Last night my look-out boat lay within four hundred yards of Cumming's Point until 11 P. M., and then moved in a northerly direction, and remained within about one thousand yards of Fort Sumter (due west of the fort) until three o'clock this morning. Nothing visited Cumming's Point during the night except three rowboats. A large steamer anchored abreast of Fort Sumter just after dark, and remained there until just before daybreak, and then moved toward the city. I have made the same arrangements for to-night that were in force last night. I have no howitzer-boats. Could you not prevent the small boats reaching Cumming's Point with your boat-howitzers?

Very respectfully, your obedient servant,

Q. A. GILLMORE,

*Brigadier-General, commanding.*

FLAG-STEAMER DINSMORE, }  
OFF MORRIS ISLAND, August 4, 1863. }

GENERAL: Yours of the 3d has been received. In order that the object of it may be better attained, it will be advisable that the officer who observed for you inside of Cumming's Point should communicate how the boats, etc. should operate when the signal is made, and in what

direction. If you will direct him to see me, there will be no difficulty in making the desired arrangements.

I am very respectfully, your obedient servant,

J. A. DAHLGREN,

*Rear-Admiral, commanding.*

Brigadier-General Q. A. GILLMORE,

*U. S. A., commanding Department South.*

HEAD-QUARTERS DEPARTMENT OF THE SOUTH, }  
MORRIS ISLAND, August 5, 1863. }

ADMIRAL DAHLGREN,

*Commanding S. A. B. Squadron :*

ADMIRAL: . . . I would say that a calcium light has been ordered from New York, and ought to reach here in the Fulton in about eight days from this time. With it I expect to be able to illuminate Cumming's Point, etc., so that my batteries and your boats can see it distinctly, and be themselves in deep darkness. I hope and believe that we can effect satisfactory results with it.

Very respectfully, your obedient servant,

Q. A. GILLMORE,

*Brigadier-General, commanding.*

HEAD-QUARTERS DEPARTMENT OF THE SOUTH, }  
MORRIS ISLAND, S. C., August 23, 1865. }

REAR-ADMIRAL JOHN A. DAHLGREN,

*Commanding S. A. B. Squadron, off Morris Island, S. C. :*

MY DEAR SIR: . . . I desire to call your attention to the project frequently discussed, and deemed practicable by us both, of investing Morris Island as soon as Sumter should be rendered harmless, and starving the enemy into terms. I think I can close communication on my left as far out as to include Lighthouse Creek. Cannot picket-boats be managed between the mouth of that creek and your monitors, so as to complete the investment? . . .

Very respectfully, your obedient servant,

Q. A. GILLMORE,

*Brigadier-General, commanding.*

[*By signals.*]

OFF MORRIS ISLAND, August 31, 1863.

GENERAL GILLMORE: I understand from my chief pilot that you will be able day after to-morrow to open and sustain a heavy fire on

Sumter. I shall therefore postpone, at least for to-night, an intended movement.

ADMIRAL DAHLGREN.

[*By signals.*]

MORRIS ISLAND, August 31, 1863.

ADMIRAL DAHLGREN: I regret that any verbal report from your chief pilot has caused the postponement of any intended movement, when time is of such great value to the enemy in increasing the batteries on Sullivan's Island. Sumter did not fire on the monitors while they were in range to-day. I will open on Sumter to-morrow with five heavy guns, including two in the naval battery.

GENERAL GILLMORE.

MORRIS ISLAND, September 3, 1863.

REAR-ADMIRAL JOHN A. DAHLGREN, *commanding*:

DEAR SIR: . . . The cutting off of the enemy's communications with this island forms an important element in this plan, and I hope it may commence to-night.

Q. A. GILLMORE,

*Brigadier-General, commanding.*

*Attempt to Destroy the U. S. S. Ironsides, off Charleston Harbor, S. C., August 20-21, 1863.—Report of Captain J. Carlin, commanding Torpedo Ram.*

CHARLESTON, August 22, 1863.

GENERAL: I have the honor to report that I attacked the Ironsides on the night of the 20th, but regret to say, however, it was not accompanied with any beneficial result.

I communicated with Fort Sumter at 10 p. m. and obtained a guard of 11 men, under command of Lieutenant E. S. Fickling. At 11.30 p. m. I passed the obstructions, and at 12 sighted the Ironsides lying at anchor in the channel off Morris Island, with five monitors moored immediately in a south-south-west direction from her, and about 300 yards distant. One monitor was anchored in the direction bearing upon Battery Gregg, and about half a mile distant. When I came within a quarter of a mile of the Ironsides I lowered the torpedoes and proceeded directly for the ship, feeling at the same time fully confident of striking her in the right place. At this time she was lying across the channel and heading for Morris Island. I steered up, keeping the object on our port bow, and when within forty yards from the ship I stopped the engine and ordered the helm put hard a-starboard.

I attribute my failure to the want of proper execution of this order. I noticed the slow obedience of the ship to her helm, and again gave

the order, repeating it three times. It was a moment of great anxiety and expectation, and, not doubting but I would strike her, I was obliged to attend to the proper command of the officers and men and restrain any undue excitement. In this I was ably assisted by the cool, courageous bearing of Lieutenant Fickling, who commanded the force stationed for defense. I discovered, as we ranged up alongside, that, in consequence of the Ironsides being in the act of swinging to the ebb, we must miss with our torpedoes, but feared that her chain cable would either ignite them or detain us alongside. In either case we must have been captured. A kind Providence, however, intervened and saved our little band from such disaster. When about fifty yards distant we were hailed, "Ship ahoy!" After deliberating whether I should not give him some warning, I felt so sure of striking him, I finally answered "Hello!" and in an official and stern tone as possible. Another hail, "What ship is that?" I answered, almost immediately, "The steamer Live Yankee."

We were still moving slowly past the bow. I gave order to go ahead with the engine, and was informed at the same time that the enemy were boarding us. Without looking to see whether such was the case, I gave the order to defend the ship, and got my arms ready in time to prevent the firing upon some sailors that were looking at us from the ports. I saw they were not boarding, and I immediately ordered the men to hold and not fire. They dropped immediately, showing specimen of the effect of good discipline. Just at this time he hailed again, "Where are you from?" Answered, "Port Royal." I found that we had ranged just clear of his bow, and out of danger of being boarded except by launches. I then went to the engine-room to see what was the matter, as fully two minutes had elapsed since the order had been given to go ahead. I found that the engine had caught upon the centre, and, notwithstanding a continued effort for at least four or five minutes, they failed to get started ahead. I was again hailed, "What ship is that?" Answered, "The United States steamer Yankee."

I again went to the engine-room, and by encouragement to the engineers found her in the act of starting. Another hail and another called me to the deck, and as none of my officers heard the question, I surmised it to be an order to come to anchor or to surrender. I answered, "Ay, ay, sir; I'll come on board." I found we were moving ahead slowly, and in two minutes must have passed out of his sight, as he commenced firing in the opposite direction. He afterward fired, sweeping the horizon, two shots passing on either side about twenty feet off.

It was my intention to attack one of the monitors, but after the experience with the engine I concluded it would be almost madness to attempt it. I therefore steered back to the city.

General, in consequence of the tests to which I have put the ship in the two late adventures, I feel it my duty most unhesitatingly to express my condemnation of the vessel and engine for the purposes it was

intended, and as soon as she can be docked and the leak stopped would advise making a transport of her.

I beg to remain, respectfully, your obedient servant,

J. CARLIN.

General G. T. BEAUREGARD,  
*Commanding at Charleston, S. C.*

[Indorsement.]

HD-QRS. DEPT. SOUTH CAROLINA, GEORGIA, AND FLORIDA, }  
August 20 [23], 1863.

CAPTAIN: Your report of operations in the attempt to destroy the Ironsides during the night of the 18th [20th] instant has been received. I regret exceedingly that you should have met with so many difficulties in your disinterested and praiseworthy enterprise; but I am happy to learn that you are still willing to retain the command of the torpedo-ram, for I know no one to whose skill and experience I would sooner trust the boat on so bold and gallant an undertaking. I feel convinced that another trial under more favorable circumstances will surely meet with success, notwithstanding the known defects of the vessel.

Respectfully, your obedient servant,

G. T. BEAUREGARD,  
*General commanding.*

Captain JAMES CARLIN,  
*Commanding Torpedo-Ram, Charleston, S. C.*

*Damages of the Bombardment of Charleston, S. C., Aug. 21-Dec. 31, 1863.—Report of Major Henry Bryan, Assistant Inspector-General C. S. Army.*

CHARLESTON, January 6, 1864.

COLONEL: In compliance with inclosed order, I have the honor to make the following report on the bombardment of Charleston by the Abolition army up to date.

The general result has been the injury of a large number of dwellings and stores, and many banks, public halls, churches, etc., by the percussion and explosion of the shells thrown; the burning of six buildings and a cotton-press December 25, 1863, by a fire originating from the explosion of a shell; and the destruction of some medical stores, August 21, 1863, by a shell bursting in the medical purveyor's office and setting fire to it. It has further caused considerable social distress by obliging thousands of persons in the lower part of the city, in order to avoid danger, to leave their homes and close their hotels, and seek refuge in the upper portion of the city or in the interior of the State. This will expose valuable property to theft and to injury from the elements. The effect upon military operations here has been comparatively unimportant, and has occasioned no loss of *matériel*, excepting

the medical stores, worth about \$1500. As a matter of prudence, all military head-quarters, offices, and hospitals have been moved out of range to the upper portions of the city, the signal corps remaining at its post, which is out of the line of fire. As equally good buildings have been found in the upper part of the city for these offices, hospitals, etc., their removal cannot be considered an injury to the army. The movements of harbor transportation have been much inconvenienced, but not practically impeded by this bombardment.

The casualties have been remarkably few, and fallen almost entirely upon the civilians who clung to their homes. The whole result has so far been utterly inadequate to the labors and boasts of the besieging forces. That they should attempt to intimidate the people of Charleston into a surrender of their city is not to be wondered at; but having plainly seen that the destruction of property did not shake their determination, it is difficult to imagine what usage of civilization would justify them in continuing it.

*Damage to Property.*—This will be large, owing to the impracticability of repairs and consequent action of the elements on buildings laid open to it. The immediate damage from the shells cannot be considered large in proportion to the area within the enemy's range. From St. Michael's steeple, which commands a full view, there is but a small appearance of destruction visible. By a rough inspection of the city yesterday with an intelligent local editor, who had already been taking accounts of the effects of the shelling, I learned that 126 buildings (including kitchens) had been struck by shells, about 85 being much injured and 41 only slightly. I presume that three-fourths of the houses struck can be repaired without pulling down any main wall; but a portion have rafters, joists, or corners very badly shattered—the South Carolina Hall (near St. Michael's Church), for instance, having been struck three times through the roof.

*Damage to Life.*—Five deaths have resulted from the bombardment—viz. Mrs. Hawthorne, No. 70 Church street, wounded by shell in right side, and died six weeks after; Miss Plane, corner Meeting and Market, left foot crushed by shell, and died in six days; Mr. William Knighton, corner Meeting and Market, right leg taken off, and died in four days; Mr. John Doscher, of German Fire Company, wounded at fire of December 25th, and since died; Rebecca, slave of Mr. Lindsay, No. 5 Beaufain street, killed instantly by shell. At the fire of December 25th there were 1 fireman, 1 policeman, and 4 soldiers slightly wounded.

*Number of Shots.*—The number fired at the city from August 21, 1863, to January 5, 1864, as noted by the observer in St. Michael's, is 472. Of these 27 were thrown on August 21st, 22d, and 24th, and 3 on October 27th. The regular bombardment may be said to have begun on November 17th, from which date to January 5, 1864, 442 are reported. Out of the 472 shells thrown at the city, 28 are reported to have fallen

short, making about 444 which struck in the city ; but in my inspection and inquiry I could only learn of some 225—viz :

Shells striking houses . . . . .	145
Shells striking yards . . . . .	19
Shells striking in the streets and on the edge of burned district . . . . .	61
Total . . . . .	225

\* \* \* \* \*

*Average Number of Shots per Day.*--During the three shellings in August (21st to 24th), four days, about 7 per day. None in September. In October only 3 shells were thrown, all in one day. From November 17, 1863, to January 5, 1864, fifty days, about 9 shells per day.

*Proportion of Shells which Burst.*—The records of this are very imperfect, and the general opinion seems to be that only one-third of the shells thrown at the city have burst. The observer's records for December are 316 shells thrown, of which 20 fell short. Of these, 123 are reported as not exploded, equal to about 39 per cent. of the number thrown, or 42 per cent. of the number which struck the city.

On January 2, 1864, 12 shells were thrown, of which one-half failed to explode.

*What Part of the City most Frequently Struck.*—I have indicated this on the accompanying map by a dotted red-ink line. It is nearly bounded north by Market street from East Bay to Meeting, down Meeting to Horlbeck's alley, and along Horlbeck's alley to King street; west by King street from Horlbeck's alley to Tradd street; south by Tradd street from corner of King to Church street; down Church street to Longitude lane, and along that lane to East Bay, and east by East Bay street. Mr. T. S. Hale, the observer at St. Michael's, reports that "the enemy's principal line of fire upon the city has been St. Michael's Church steeple, radiating to the north-eastward as far as St. Philip's Church," and generally limited westwardly in its range to Archdale street. "Since January 1st the enemy appears to have made St. Philip's Church steeple his line of fire, hence the shells striking higher up in the city." On the map accompanying the wards are marked in separate colors, and the district burned in 1861 by a dark-brown tint. The shells first thrown at the city were 200-pounder Parrotts, but afterward the 100-pounder Parrotts.

People are occasionally found living in the lower part of the city apparently indifferent to the danger of the enemy's fire. I think there are a good many west of Meeting street. The Blakely-gun battery appears to be the only one in the line of fire.

Respectfully submitted, HENRY BRYAN,  
Major and Assistant Inspector-General.

Lieutenant-Colonel A. ROMAN,  
Assist. Insp.-Gen. Dept. of S. C., Ga., and Fla.

*Recapitulation of Enemy's Shelling of Charleston.*

Month.	Reached city.	Fell short.	Total fired.
November, 1863 . . . . .	77	10	87
December, 1863 . . . . .	283	33	316
January, 1864 . . . . .	990	533	1523
February, 1864 . . . . .	964	763	1727
March, 1864 . . . . .	236	89	325
Grand total . . . . .	2550	1428	3978

ALFRED RHEIT,  
Colonel, commanding.

CHARLESTON, March 4, 1864.

*Battery Wagner, with Three Guns, fights the Iron-Clad Squadron, carrying Twenty-eight Guns.—A Memorable Day.*

HEAD-QUARTERS BATTERY WAGNER, }  
August 17, 1863, 9 P. M. }

CAPTAIN: I had the honor last night to forward report up to 1.30 A. M. this morning, when slow firing was going on from our land-face, which continued up to 4.30 A. M.

The enemy responded with a vigorous mortar-fire, ceasing about the same time as ours.

At 5 A. M. they opened a severe fire of Parrott guns from their works on Morris Island to our right, ceasing just before 6. There were no casualties reported from this fire, and no material damage done.

Just after 6 A. M. a monitor, and then the Ironsides, were seen drawing up, and, according to the views of the commanding general, were allowed to come in close. An action with these and other monitors commenced about half-past 6, Lieutenant J. Julius Alston's detachment manning the two columbiads, and a squad of Company B, Lucas's battalion, manning the rifled 32-pounder, directed mostly by Captain Robert Pringle and sometimes by Lieutenant E. B. Calhoun. Lieutenant Alston acted as gunner for right columbiad, directing his fire on left and nearest monitor, distant about 600 yards. Sergeant D. H. Welch, Company E, First Artillery, directed the fire of left columbiad against the Ironsides, distant about 700 to 800 yards.

It was impracticable to train the right columbiad on the Ironsides.

Captain Pringle, Company B, Lucas's battalion, directed the fire of the rifle-gun against the left and nearest monitor, she being about 200 yards nearer than the Ironsides, for about an hour, and then against another monitor, which came in still nearer on the right, for about another hour, when I directed the men to leave their guns. These monitors threw canister and shrapnel frequently, causing great annoyance to the cannoneers.



Captain Pringle fired over 40 bolts from his gun, with little effect at first, but thinks he struck with one shot out of every three during the last two-thirds of his firing. During this firing Captain Wampler of the Engineers rendered gallant and effective service in repairing traverse circle to this gun.

After Lieutenant Alston had fired about five shots from the right columbiad, the monitor came in so close—within 500 yards—that he was unable to depress the gun sufficiently to strike the turret, though he fired some six shots over it in very good line.

Toward the last of our firing (which lasted about two hours and ten minutes) the monitor, which had been receiving Lieutenant Alston's fire, drew off to the fleet apparently injured, and his fire was transferred to the next monitor to the right.

Lieutenant Alston fought his gun all through our firing, only interrupted by temporary disabling of one of his eccentric wheels. Sergeant Welch handled his gun well, and is reported to have struck the Ironsides several times. His detachment was relieved, being worn out, at about a quarter before 8 with detachment of Company E, Charleston battalion, under Captain F. T. Miles. They had been at their gun about ten minutes when a shell burst among them, wounding or stunning every man, and thus stripping the gun-chamber. Lieutenant Alston had no men for it, and, indeed, had been assisted by three or four men of Pringle's company.

Captain Miles, being stunned and very weak, looked after his mangled men in the hospital, and Lieutenant Palmer, Company E, Charleston battalion, who had been assisting Captain Chichester for an hour as adjutant, was soon after ordered to get a detachment and take charge of the gun, which he failed to do; but finally a detachment was supplied under Lieutenant J. W. Axson, who received a slight contusion in the knee before the gun was loaded. They only fired it once, about 8.40 A. M., when, with the advice of Captain Chichester, my chief of artillery, all the cannoneers on the sea-face were called off to the passages and bombproofs, as their exposure was greater than any attainable result would justify. Six monitors came up, and certainly five of them were firing on this battery at once, coming as near as they pleased. Various land-batteries of the enemy, including their strong work in rear of the stockade, kept up a brisk fire, but I do not think many casualties resulted from it.

Just before 9 A. M. my acting aide, Lieutenant John D. Hopkins, Company G, First Georgia, carried an order to Captain Davenport, commanding First Georgia in the sandhills, to detail three gun-detachments from his command, and led them up, one man being killed by shrapnel in execution of this order. They reported, under Lieutenant H. A. Elkins, before 10 A. M., too late to take part in morning fight, and were put in charge of left columbiad.

At 9.20 parapet in front of left columbiad was badly damaged, and Captain Wampler soon after took measures to strengthen it.

Captain Wampler and Major Bryan examined magazines and reported them safe. Five monitors deployed in line.

At 9.45 the firing slackened a short time, the monitors drawing off toward the south, the Ironsides stationary. At 10.15 two monitors moved to left of this battery, and soon a very heavy fire opened.

Just before 11 A. M., Captain J. M. Wampler, chief engineer, was killed, while writing at head-quarters, by a fragment of a shell cutting his spine. I greatly deplore the loss of this gallant man.

At 11.05 A. M. an ammunition-chest was exploded by enemy's shell at the field-guns, and some 12-pounder shrapnel and shell destroyed; at 11.45 six monitors deployed, two to the left and four to front and extreme right.

At 12.15 all the monitors, excepting one, moving to the south, but one drew near and fired occasionally, and about half-past 12 all firing ceased; the monitors and Ironsides hauled off from a mile to one and three-quarters. The men were turned out of the bombproof to eat and get fresh air. At a little after 1 P. M. the enemy opened a mortar-fire (not good), which ceased at 2.30 P. M.

At 3.45 one monitor approached battery and opened fire, soon joined by another about 4 P. M.; returned by our two columbiads and one rifled gun. Unfortunately, the rifled gun was spiked in attempting to load it, from the priming wire having been carelessly left in the vent and broken off flush in trying to draw it out. At 4.10 a large hole was torn in parapet in front of the north columbiad, but Lieutenant Alston continued fighting it with an infantry detail, shovelling away the sand; finally, the Yates traversing gear got out of order.

At 4.40 a XV-inch shell burst under the chassis of left columbiad, tearing the chassis badly, injuring the Yates traversing gear, and tearing the platform slightly.

Fortunately, only one of the men of the detachment was injured, and he slightly. They were from First Georgia, Lieutenant Elkins in charge, and behaved gallantly.

4.45 P. M.—Our fire ceased about this time, but the enemy's fire from two monitors, at close range, continued till nearly six o'clock, since which time all has been quiet.

August 18th, 3 A. M.—All quiet, garrison very much exhausted, repairing damages.

Captain Gregorie has reported as engineer.

Very respectfully, your obedient servant,

LAWRENCE M. KEITT,

*Colonel, commanding.*

Captain W. F. NANCE,

*Assistant Adjutant-General.*

## CHAPTER VII.

*Proceedings of a Council of Officers held at Fort Sumter August 24th.*

FORT SUMTER, August 25, 1863.

COLONEL: I send you two copies of our proceedings of yesterday afternoon, one for Colonel Gilmer and yourself; the other please have signed and returned.

From examination, we find the 11-inch gun is severely if not seriously cracked at the junction of the right trunnion with its rimbase.

Very respectfully,

F. H. HARLESTON,  
*Captain First South Carolina Artillery.*

Colonel HARRIS,  
*Corps of Engineers, Charleston.*

[Inclosure].

*Proceedings of a council of officers convened at Fort Sumter, Charleston harbor, in compliance with the following letter:*

HD-QRS. DEPT. SOUTH CAROLINA, GEORGIA, AND FLORIDA, }  
CHARLESTON, S. C., August 24, 1863-10.30 A. M. }

COLONEL HARRIS:

COLONEL: General Beauregard directs that you proceed immediately to Fort Sumter (together with Colonel Gilmer, if agreeable to him), to confer with Colonel Rhett, his chief of artillery, and Lieutenant Johnson, Engineers, to report upon the defenses of the place or the advisability of abandoning the work. In the attempt to reach the fort the general desires that a proper regard should be had to your own safety. You must not undertake the trip if too dangerous.

Respectfully, your obedient servant,

A. N. TOUTANT BEAUREGARD,  
*Aide-de-Camp.*

In compliance with the above letter, a council of officers, consisting of Colonel Gilmer, C. S. Corps of Engineers; Colonel Rhett, First South Carolina Artillery; Colonel Harris, C. S. Corps of Engineers; Major Blanding, First South Carolina Artillery; Captain F. H. Harleston, First South Carolina Artillery; and Lieutenant Johnson, Corps of Engineers, met at Fort Sumter on the afternoon of August 24, 1863.

Captain Harleston acted as recorder. The first proposition proposed for consideration was, "The present offensive condition of the fort."

Lieutenant JOHNSON, Engineer Corps: The present offensive condition of the fort is very limited; one very fine gun (11-inch) capable of

being fired with advantage; two others (10-inch) at disadvantage, in consequence of shattered condition of parapet.

Captain HARLESTON of same opinion as Lieutenant Johnson.

Major BLANDING: The offensive condition of the fort is very nearly destroyed; only one gun (11-inch) that can be used with any advantage.

Colonel HARRIS indorses Lieutenant Johnson's opinion.

Colonel RHETT: In action it would be impracticable to use but one gun, the 11-inch, and that would soon be disabled.

Colonel GILMER of the same opinion as Lieutenant Johnson.

Second proposition: Can offensive power still be given to these guns by additional cover and change of location?

Lieutenant JOHNSON: Yes; by sandbag épaulement and timber platforms in rear of and between present platforms.

Captain HARLESTON: Consider it impracticable on account of present shattered condition of the fort, and that sufficient time will not be allowed.

Major BLANDING: Agree with Captain Harleston.

Colonel HARRIS: It can be done in present condition of fort, if time is allowed.

Colonel RHETT: Would like to see it carried out, but consider it impracticable.

Colonel GILMER: It is entirely within the capacity of the engineer to accomplish the work in the manner suggested by Lieutenant Johnson, if not under fire, at night when the fire ceases.

Third proposition: Capacity of the fort as a defensive position, in its present condition, against a barge attack, and the number of men needed.

Lieutenant JOHNSON: I think the capacity of the fort sufficient, and that it needs 300 muskets.

Captain HARLESTON: I think the capacity of the fort sufficient, and that it needs from 250 to 300 muskets.

Major BLANDING: Without outside assistance, in its present condition, 500 muskets will be needed.

Colonel HARRIS: Agree with Lieutenant Johnson.

Colonel RHETT: The navy will not be able to assist in an attack from barges; the fort can be held in its present condition with no less force than 400 effective men, and a large part of those should be kept under arms during the night, as barges can come within fifty yards without being seen.

Colonel GILMER: The defensive capacity of the fort is sufficient if garrisoned with 300 effective men, giving them the assistance of splinter-proof cover and sandbag épaulements.

Fourth proposition: Power of the fort to preserve its present defensive condition against probable attack.

Lieutenant JOHNSON: Against the possible combined attacks of the fleet, Parrott guns, and mortars, thirty-six hours.

Captain HARLESTON: Agree with Lieutenant Johnson.

Major BLANDING: Against a combined vigorous attack, twelve hours.

Colonel HARRIS: Cannot undertake to answer as regards time.

Colonel RHETT: The eastern wall is much shattered by the fire of the 7th of April, and has never been repaired, excepting two casemates, which have been rebuilt with new masonry; the wall has been reinforced in the casemates with sandbags; it has also been seriously damaged by fire from the land-batteries on Morris Island. My opinion is that a fire from the iron-clad fleet for from two to three hours would destroy the integrity of the wall, if it did not bring it down. A combined fire from land-batteries on Morris Island, with a monitor attack, would most probably bring down a large part of the wall. The inner corner wall of eastern magazine is now cracked. The fort wall adjoining the pier of the upper magazine has been completely shot away, and I think a concentrated fire of two hours on the junction of the upper and lower magazines would render the magazine unsafe. The north wall of the upper western magazine is unprotected, and is exposed to a reverse fire from the fleet firing one or two points north of perpendicular to east face of fort. A few shots upon this wall, striking about the junction of upper and lower magazine, would render the magazine unsafe. This place is now being reinforced with eight feet of sand. The roof of the hospital is now only protected by brick arches that would be crushed through by a few shells.

Colonel GILMER: From the examination I have been able to make as to the effect of the bombardment up to this time, I think the fort will remain tenable against any probable attack for many days if the Engineer officers be supplied with the labor and material necessary to reinforce points comparatively weak.

ALFRED RHETT,

*Colonel, commanding.*

ORMSBY BLANDING,

*Major First South Carolina Artillery.*

F. H. HARLESTON,

*Captain First South Carolina Artillery.*

JOHN JOHNSON,

*First Lieutenant Engineer Corps, Provisional Army C. S.*

The foregoing is a correct report of what occurred at the consultation of the officers named, but we do not consider it as embodying our opinion in full as to "the advisability of abandoning the work," as called for by the commanding general in a letter, a copy of which is embraced in the foregoing proceedings.

J. F. GILMER,

*Colonel, and Chief of Engineer Bureau.*

D. B. HARRIS,

*Lieutenant-Colonel, and Chief Engineer of Department.*

*Report of Colonel Jeremy F. Gilmer and Lieutenant-Colonel D. B. Harris, C. S. Corps of Engineers, of Inspection Aug. 24, 1863.*

OFFICE OF THE CHIEF ENGINEER, }  
CHARLESTON, S. C., August 25, 1863. }

GENERAL: We have the honor to report that in compliance with your instructions we visited Fort Sumter yesterday afternoon, made a careful examination of its condition, and held a consultation with a portion of its officers, a copy of which we hand you inclosed. In addition to our answers to certain questions propounded at that consultation, we beg leave to state that, in our opinion, it is not advisable to abandon the fort at this time. On the contrary, we think it should be held to the last extremity. How long it may be held is now only a matter of conjecture, but there are many elements of defense within the fort, in its present shattered condition, which if properly used may enable a resolute garrison to hold it for many days. The question of its abandonment, whenever it may arise, we respectfully suggest, should be determined by the commanding general, and not left to the discretion of the commander of the fort.

We have the honor to be, general, very respectfully, yours,

J. F. GILMER,

*Colonel, and Chief of Engineer Bureau.*

D. B. HARRIS,

*Lieutenant-Colonel, and Chief Engineer of Department.*

General G. T. BEAUREGARD,

*Commanding, etc.*

[Indorsement.]

HEAD-QUARTERS DEPT. S. C., GA., AND FLA., }  
CHARLESTON, S. C., August 26, 1863. }

The opinion of Colonel Gilmer and Lieutenant-Colonel Harris of the Engineers is approved. Fort Sumter must be held to the last extremity — *i. e.* not surrendered until it becomes impossible to hold it longer without an unnecessary sacrifice of human life. Evacuation of the fort must not be contemplated one instant without positive orders from these headquarters.

G. T. BEAUREGARD,

*General, commanding.*

*Extracts from Major T. B. Brooks's Journal of the Siege of Wagner (Gillmore's Report).*

July 25, 1863.— . . . . “The enemy opened on our advanced works on the right this morning, with columbiads and a Brooke rifle, from what was afterward known as Battery Simkins on Shell Point, distant

from the second parallel about 3300 yards. This is the first fire we have received from James Island, and was particularly heavy to-day. (It afterward, with the fire of Sumter and Battery Gregg, continued day and night.) Our batteries reply by firing at Wagner, which does not respond. This James Island battery will be most annoying, because our works are not, and could not easily be, defiladed against it, either in profile or trace, on account of the form and scarcity of ground on which we have to operate."

*August 9th.*—"The detail for to-night's work is 124 volunteer engineers, under Lieutenants Farrand and Talcott, and 80 infantry, under Captain Walker. The engineers were in advance. Two hundred and sixty yards of trench were opened, and a splinter-proof parapet, from six and a half to eight feet high, built throughout its length. No portion was revetted. Our grand-guard outposts were but thirty yards in front of the working-party, and the enemy's pickets, who could be seen, were apparently not over thirty yards farther. The engineers, on their knees, shovelled almost noiselessly. I could scarcely hear or see them from the line of outposts thirty yards distant. The following method of setting the engineers at work was adopted: They carried no arms. Each man held a short-handled shovel in his right hand; in the left, at intervals of six feet, each grasped a marked rope. The engineer officer who located the line took the lead. The men marched forward stooping. At a signal the rope was dropped, and each man went to digging a pit where he stood, throwing the earth over the rope; these pits were connected and good cover was soon obtained. . . . At about two o'clock on the morning of the 11th, when the last-mentioned work (a battery near the centre of the parallel) was about one-half completed, Wagner opened a heavy fire of grape, canister, and shell, which, with the fire of the James Island batteries and Sumter, stopped our working-parties entirely for the first time in the siege."

. . . . "Dr. Grant undertook to-night (August 10th) to light up Cumming's Point with two calcium lights placed in the left batteries, distant 3000 yards. The object was to reveal to our gunners any of the enemy's succor-boats that may be attempting to communicate with his forces on Morris Island, and interrupt the operations with our fire. On the night of August 4th, Captain Payne, the scout, and party were captured while repeating their endeavors to discover these relief-boats. Neither plan fully succeeded."

*August 23d.*— . . . . "At daylight the enemy opened on this new work with artillery from Wagner, and completely destroyed it, knocking the gabions to pieces and caving the parapet back into the trench for twelve yards in length. This part of the work had to be abandoned. . . . A small 'redan' was built in front of the left of the fourth parallel by the flying sap, the enemy's pickets being within twenty-five yards. This . . . . gave cover in reverse against the fire of James Island, which

is producing more casualties among our troops than at any previous time, averaging in the special guard of the advanced trenches ten per day. On one day one of these regiments, the Eighty-fifth Pennsylvania volunteers, numbering three hundred, lost twenty men." . . . .

*August 24th.*— . . . . "This afternoon a mortar was opened on our fourth parallel from Wagner. Three sappers were wounded by it. This mortar proved to be a great annoyance. Its fire was directed on the head of the sap, was very accurate, and our sappers had no shelter from it. Six such mortars, well served, would, I think, have stopped our work at this period until subdued by our superior fire." . . . .

*August 25th.*— . . . . "The fire from James Island batteries has been very accurate, and much felt in the fourth parallel to-day. Several casualties took place among the engineers and infantry. I witnessed three successive shots take effect among our troops. This is surprising, as the enemy is using smoothbore guns at ranges of from 3000 to 4000 yards." . . . .

*August 26th.*—(The capture of the "Ridge" at 6.30 p. m. advanced the attack to its fifth parallel.) "The first torpedoes were now found. One exploded, throwing a corporal of the Third United States Colored Troops, of the fatigue detail, twenty-five yards, and depositing him entirely naked, with his arm resting on the plunger of another torpedo. . . . The discovery of these torpedoes explains what has been to me one of the greatest mysteries in the defense of Wagner—*i. e.* the fact that no material obstacle of any amount could be discovered in front of the work, not even after our two almost successful assaults. Torpedoes were the substitute." . . . .

*August 27th.*— . . . . "Eight torpedoes were discovered inside of our advanced line to-day. . . . They were easily rendered harmless by boring a small auger-hole through the wood of which they are constructed, and pouring in a sufficient quantity of water to destroy the explosive power of the powder. This was afterward practised."

*August 29th.*— . . . . "I ordered the sharpshooters to-day to endeavor to explode the torpedoes in advance of our works by firing at their plungers. Hitting the plungers did not explode them."

*August 31st.*— . . . . "This night three casualties occurred in the guard of the advanced trenches from the explosion of a torpedo, over the plunger of which one of the men crept in taking his position." . . . .

*September 3d.*— . . . . "Destructive torpedoes, having a delicate explosive apparatus, are planted thickly in our path. . . . The One Hundredth New York volunteers, Colonel Dandy commanding, Eighty-fifth Pennsylvania volunteers, Lieutenant-Colonel Purviance recently commanding, and Third New Hampshire volunteers, Captain Randlett commanding, comprising the three regiments of volunteer infantry detailed on the 19th ult. as the guard of the advanced trenches, were to-day relieved from this responsible and hazardous duty. Their aggregate



number of casualties in this brief period is 105, or 10 per cent. of the whole force. Four-fifths of these were caused by the enemy's artillery fire." . . . .

*September 6th.*— . . . . "The firing of the Ironsides is excellent. A United States flag is kept constantly at the head of the sap, that she may direct her fire so as not to endanger us. Her shells strike the sea-face of the work just in advance of the flag, ricochet over the parapet, fall, explode very regularly, and search every part of the work that can possibly be reached by a mortar-fire. . . . One sapper of the engineers and three infantry wounded by the explosion of a torpedo."

[The fort evacuated night of 6th-7th of September.]

*September 7th.*—"The following injuries, inflicted on Fort Wagner by the artillery fire of the past two days, were observed this morning: Of the sixteen pieces of ordnance which constituted the armament of the fort when it was taken, and in which there had probably been no change during the bombardment, only three were wholly disabled and unserviceable. This after forty hours' bombardment at short range by an army and navy supplied with the best heavy guns in our service, manned by experienced artillerymen, and during which the army alone threw over 3000 projectiles at the work! Only part of these were directed at the guns of the work.

"The most serious injury to the material of Fort Wagner was inflicted on the most southerly of the sea-face traverses, in which was situated a bombproof shelter. A timber forming the south upper corner of the sheathing of this bombproof shelter was struck by a shot from the land-batteries and considerably splintered. To reach this timber at least ten feet of sand had been penetrated or removed by successive shots. . . . Considerable earth which covered the south end of the main bombproof shelter and the magazine just east of it was removed by our fire. About seven feet were left, however, which was enough to make both structures secure against a much longer-continued fire."

---

CHAPTER VIII.

<i>General Orders</i> }	HEAD-QUARTERS, FORT SUMTER, }
<i>No. I.</i> }	September 5, 1863. }

I. In pursuance of Special Orders No. 298, par. III., I assume command of this post.

II. The garrison, consisting of the Charleston battalion, will be under the command of Major Blake.

III. At dark every evening a detachment of fifty men, under the command of a captain, will be stationed on the crest of the gorge-wall, in readiness to repulse a landing at that point.

REPORTS, CORRESPONDENCE, DESPATCHES, ETC. cix

The men will not be allowed to take off their accoutrements, and will have their guns loaded, with fixed bayonets, and ready for immediate action; an officer of this detachment will be constantly awake.

IV. A detachment of twenty men, under the command of a lieutenant, will occupy the broken embrasures on the north face; a non-commissioned officer will keep constantly awake; in other respects the same precautions will be observed as have been ordered for the south face.

V. In case of an attack in barges, which will be announced by beating the long roll, the rest of the command will form on the parade in rear of the gorge-wall, whence positions will be assigned to any weak point.

VI. Company commanders will inspect their commands every evening at retreat, and will be careful in seeing that every rifle is in perfect order and that each man is provided with his complement of ammunition.

VII. It is positively forbidden to throw slops, dirt, or offal of any kind in any part of the fort, and commanding officers of companies will see that no improper uses whatever are made of the parade-ground.

The attention of the provost sergeant is also called to the fact that this is under his special supervision.

Each company will have a slop-barrel, in which all the offal of the company will be thrown. These barrels will be daily emptied by the police squads of the several companies.

VIII. Company officers will sleep near their respective companies, see that they are kept together, and that their arms and accoutrements are kept in such a way that they can be assumed at a moment's notice.

By order.

STEPHEN ELLIOTT, JR.,

*Major, commanding.*

(Signed) W. MASON SMITH,  
*Adjutant.*

*Lieutenant-Colonel D. B. Harris, Chief Engineer, recommends the Evacuation of Morris Island Batteries.*

OFFICE OF CHIEF ENGINEER, }  
CHARLESTON, S. C., Sept. 6, 1863. }

Brigadier-General THOMAS JORDAN,  
*Chief of Staff:*

GENERAL: I have the honor to report that I visited our works on Morris Island to-day, and in consideration of their condition, of our inability to repair damages at Battery Wagner as heretofore, of the dispirited state of its garrison, and of the progress of the enemy's sap, I am reluctantly constrained to recommend an immediate evacuation of both Batteries Wagner and Gregg.

The thirty-six hours' severe bombardment to which these batteries have

been subjected, confining the troops to the shelter of the bombproof, has resulted in so dispiriting the garrison at Wagner as to render it unsafe, in the opinion of its chief-officers, to rely upon it to repel an assault should the enemy attempt one. The head of the enemy's sap is within forty yards of the salient of the battery, and he is making rapid progress in pushing it forward, unmolested by the fire of a single gun, and with scarcely any annoyance from our sharpshooters.

In consequence of the accuracy of fire of his land-batteries, which are now in close proximity to Battery Wagner—say from 500 to 800 yards—aided by reverse fire from his fleet, it is impossible, in the opinion of the officers of the fort, to keep up a fire either of artillery or small-arms; and the enemy is thus left free to work on his trenches, which he is pushing rapidly forward, the head of his sap being, as above stated, within forty yards of the salient of the work, which is so seriously damaged by a battery of Parrott guns, kept constantly playing upon it, as to render it untenable. This difficulty could, however, be overcome by the erection of a parapet across the gorge of the salient, and the conversion of the bombproof covering into another parapet overlooking the salient, if it were practicable to work, as heretofore, at night. The covering to the bombproof and magazine also needs repair. We have been thus far able not only to repair damage at night, but to add from day to day to the strength of the battery; but now that the enemy's sap is in such close proximity to the battery, and he has contrived to throw light upon the parapets at night, it is impossible to do so without a heavy loss of men. In the effort last night to repair damages the commanding officer of the fort reports a loss, in killed and wounded, of sixty to eighty men of the working-party alone. Without our ability to repair damages at night the battery will become, under the incessant fire of the enemy's land-batteries and fleet, untenable, say, in two days.

It is in view of these facts that I have thought it my duty to make the recommendation at the commencement of this report.

I have the honor to be, general,

Yours, very respectfully,

D. B. HARRIS,

*Lieutenant-Colonel and Chief Engineer.*

*Journal of Personal Service, as Chief of Artillery, at Battery Wagner, September 3d to 7th, inclusive, written soon after the Evacuation of Morris Island, by Captain T. A. Huguenin, First South Carolina (regular) Infantry, and kindly furnished for Publication in this Work, not having before been Printed.*

While in command of Battery Beauregard, Sullivan's Island, with my company of sixty-five men, I received an order, about dinner-time

on Thursday, the 3d of September, assigning me to duty on Morris Island. Transferred that night by steamer to Fort Johnson, and thence by small boats to Cumming's Point, we relieved Captain Press Smith's company about midnight from duty at Battery Gregg. By order of Colonel L. M. Keitt, commanding our troops on Morris Island, a detachment of my company (thirty men), under Lieutenant E. A. Erwin, was sent on to Battery Wagner; the remainder were kept at work mounting a IX-inch Dahlgren gun until daylight Friday morning, the enemy permitting no such work when they could see it. After a breakfast on rice and bacon, cooked, but served up on *sabots* and eaten with sticks, I had just lain down for rest when an order came from Colonel Keitt for me to repair immediately to Battery Wagner, where Major F. F. Warley (Second South Carolina Artillery), chief of artillery, had been severely wounded, and I was wanted to fill his place. Mounting a horse and riding rapidly through the showering shell, I reached the work in ten minutes, reported to Colonel K., and was put in charge of all the artillery. For the next two hours I was busily engaged inspecting the armament of the post. The enemy were digging away rapidly in their approaches, now within about 150 yards of our ditch. I found the guns very much injured from long service and exposure; the carriages and chassis weakened by being struck and splintered. The prospect was not cheering; the soldiers, worn and exhausted, could find no comfort in the bombproof on account of the hot, close air, and were lying at the guns close to the parapet, but exposed to the broiling sun and the flying fragments of shell. I thought it my duty to take a look at the enemy's sap, but hardly had my cap appeared before the crest when a sharpshooter's bullet whistled close to me and changed my mind. A good view, however, was obtained by peeping more discreetly through the loophole of one of our own sharpshooters; and I at once came to the conclusion that our guns should be opened. Accordingly, at 3.30 P. M., with consent of the colonel commanding, we commenced firing, and in about one hour the enemy were compelled to suspend work on their advanced trench, so that, in the scarcity of ammunition, our fire was suspended also. The enemy toward evening did some beautiful firing at one of my guns which had particularly annoyed them. Their practice was so accurate as to compel me to close the embrasure to prevent them from destroying the gun and carriage. Just before sunset firing on the part of the enemy ceased, and by the light of a magnificent September sunset I took a careful view of the whole fort. The parade was strewn with parts of broken guns, carriages, and chassis, lumber and splinters, and last, but not least, thousands of fragments of shell and shot of every description which had been thrown into the fort. One 8-inch howitzer was broken in half and thrown thirty feet from its original position. The men lay in groups close under the parapet, eating raw bacon and biscuit, tired, dirty, and sleepy, for there was no rest for

them day or night. While the last rays of the sun began to disappear behind the woods on James Island the infantry were marched out from the bombproof, and took their places along the parapet to guard against assault. The enemy having recommenced work, I again began firing. This was returned from their mortars (coehorn), which were so near that when they were fired so little powder was used the report sounded no louder than the falling of a heavy piece of timber on the ground.

About 10 P. M., the commander agreeing, I moved out of the fort cautiously by the western sally-port, accompanied by Major H. Bryan, A. A.-G., for the purpose of selecting a position for a forward flank-work to mount one gun and enfilade the enemy's approaches, checking them as we could no longer do from our front. To avoid the sharpshooters, firing by their calcium-light as well as in the day-time, we were obliged to crawl along on hands and knees until about twenty-five yards beyond the ditch; then, concealing ourselves in the edge of the marsh, we crept forward a little farther to the point I had observed during the day. Finding the position to be what I desired, and that my plan would be feasible, I returned, and, obtaining Colonel Keitt's indorsement, sent a request to Brigadier-General Ripley for means and authority to do the work. But as the despatch could not reach him before next day (the last of the fort's defense), nothing came of my plan. Between 3 and 5 o'clock I tried to get some sleep, but the heat and odor of the bombproof, together with the difficulty of coiling up on an ammunition-chest of half my length, defeated all my efforts.

Early Saturday morning, the 5th of September, the fire of the enemy was increased with their heaviest weight of metal; rifle-guns of 100 and 200 pounds from their lines were added to their mortars, while the New Ironsides and some monitors steamed up and engaged the fort at close quarters. The bombardment had now actually commenced; all the firing on previous occasions from the land and naval batteries was as nothing to this. No place was safe from the flying fragments of bursting shells but the magazines and bombproof quarters. Passages, corners, and entrances which had always been considered safe were now like slaughter-pens. . . . About noon a traverse which had been protecting the entrance to one of the magazines and the hospital was cut away, and the passage obstructed by large quantities of sand thrown in and filling it up. It was necessary to have the passage cleared, and a detail of men was accordingly sent to shovel it away. Hardly had the attempt been made before all except one were brought in dead or wounded. Again and again it was attempted, until finally a space was cleared sufficient to admit light and air to the hospital. While this was going on I could hear the frequent cry "Call the ambulance corps," and presently some poor fellow would be brought in horribly mangled from the dangerous spot. The artillerymen who were kept at the guns were continually

either killed or wounded; in our detachment Lieutenant Miller, in charge, was the only individual uninjured.

So it continued all day, and our only hope was that when night came fresh troops might relieve us, or that the fire would be slackened and some repairing of damages might be done; for the earth-filling on one side of magazine No. 2 had been nearly all knocked off. But the fire increased toward night, and, instead of having reinforcements, we learned that the enemy intended making an attack with small boats upon Cumming's Point, and therefore no supplies or troops could be brought over. As soon as it was dark a portion of the garrison of Wagner was sent to Gregg, and the rest of us made ready for an assault on Wagner. No sleep, constant care, and excitement had made me so exhausted I could scarcely walk, but round I went, rousing up one or encouraging another. Hour after hour we waited that dreadful night, little regarding the shells exploding around us in our great anxiety for Gregg; for we knew that if the battery fell our fate would be sealed. About one o'clock firing was heard in that direction, and soon came the news of a successful repulse for us. Colonel Keitt and I walked around the fort telling the men to cheer them up, and with marked success. We then looked every moment to be stormed ourselves. No work of repair could possibly be done. A fatigue-party performed the hazardous task of removing all powder from the endangered magazine into the safer one. No supplies of any kind had come over from the city; the commissary stores had been destroyed the day before; our garrison had only a little biscuit and raw bacon; our water had been exhausted and every one made thirsty by the diet of raw salt meat. In this extremity we had recourse to digging small holes in and around the fort, but only to find the water springing thence so impregnated with the decay of bodies newly buried all around as to sicken and disgust us.

Sunday morning dawned with peace and brightness on the face of nature, but with heavier gloom for us. There were no signs of assault, but the bombardment became more furious. We withdrew the infantry and prepared for another day of exhausting trial. Soon after daylight the cry of "Fire!" startled me, and, hurrying out, I found that just in the gun-pit next our principal magazine the carriage of a 10-inch columbiad, which had been struck the day before, was in flames. The gun was standing up almost perpendicular, the trunnion having been broken off; and I knew that as soon as the piece became heated it would be discharged and thrown violently backward, to the injury of our only remaining magazine. So, without water to put out the fire, what was to be done? Seizing a shovel, I called aloud to some men near by to assist me in throwing sand upon the fire. We checked it, and then, procuring a kettle of water, we poured its contents down the muzzle and destroyed the powder of the charge. This was a narrow escape, and, knowing the importance of it, I worked so hard that I nearly fainted.

As I walked out of the passage an incident occurred which was heart-rending, and I can never forget it. A 100-pounder rifle-shell struck the parapet, behind which were two sharpshooters, brothers. It knocked away the sand, and hurled one poor fellow fully twenty yards into the parade. He was instantly killed, and while lying there doubled up, with his gun still grasped in his hand, he was seen by the other, who had been stunned by the shock received at the parapet and had now recovered. Too weak to go to his brother, and supposing him to be yet alive, the disabled soldier uttered piteous cries for some one to take his brother up, but was himself soon lifted by friendly hands and borne to a place of safety. . . . I resumed my inspection, and then went to take a little rest for an hour or two.

About the middle of the day Colonel D. B. Harris, chief engineer of General Beauregard's staff, arrived on a visit from head-quarters, having landed at Cumming's Point in a small boat and made his way at great risk to the front. He made a careful examination of the fort and the enemy's threatening approaches, and then returned to the city. We surmised, but did not immediately know, his opinion of the situation.

The garrison was completely worn down: seldom if ever before had men been subjected to such a trial; for, over and beyond the perpetual bursting of the shells, there were the heat, thirst, crowded, unwholesome, poisonous atmosphere of the quarters to be contended with. Some of the men had been on duty eight days and nights at the post, and were so exhausted that I could hardly get them to man their guns.

Just at dark an officer arrived with orders, and soon after I was called into consultation with the commander. The plan of evacuation and retreat was agreed upon, and I proposed the plan of operations for the rear-guard, to which I had been assigned the command at my own request. About 8 o'clock a regiment of Georgians, portions of two companies and one whole company of artillerists, left. This was the beginning of the end. . . . Everything went on well. At 11 o'clock word came from the point that more troops should be sent. The Twenty-fifth South Carolina volunteers at once left the battery, and with them Colonel Keitt and all others except the rear-guard, consisting of sixty-three men and a few officers. . . . Thirty minutes after, I sent off half of the rear-guard, some to Cumming's Point and a few halfway to man a gun which had been placed there to cover our retreat. All that were left in Wagner then were thirty-five men and seven officers. I now distributed these men all along the whole length of the fort, and ordered them to keep up a continual firing with small-arms in order to make the enemy believe that the whole garrison was still in the battery. I then took out the slow-match, which had been previously fixed, and gave it to Lieutenant E. Mazyek, my ordnance officer, going round myself with Captain C. C. Pinckney to destroy the implements and spike the guns. The shelling was all this time very severe. I gave Captain Pinckney

the hammer, and we began spiking from the extreme right. Just as the first gun was spiked a Union soldier was heard to exclaim in a loud voice, close in front of the fort. We stopped and listened anxiously, expecting the alarm would certainly be given and the fort immediately assaulted. But the cry had come from one of the enemy wounded by a sharpshooter of ours, Kelley by name. The spiking was then renewed, but to prevent discovery I had to make a cushion of a haversack partly filled with sand, hold it over the spike, and so deaden the sound of the blow.

Everything, thus far, was carried out most successfully; and the men were all taken from the parapet and gathered at the sally-port, ready to leave as soon as word came that the boats were ready for us. But no word came. The delay was growing hazardous, and was trying to the strongest nerves. Not willing to send the men back to the parapet, I determined to go myself into the bombproof and hospital to see if anybody remained behind. As I walked through the darkness, lighted by a lantern, and felt the change from a crowded work, where a few hours before twelve hundred men had been closely packed, my search was interrupted by stumbling over two dead bodies, horribly mangled and left unburied in the haste of departure. A moment's pause in that dark solitude was the most impressive of my life—with the silent dead at my feet, the subdued roar of the bombardment heard from without, and the stillness within, broken only by the slow, distinct drip, dripping of the dampness overhead upon the plank floor beneath.

Convinced that not a living man was left behind, I returned to the sally-port in time to hear that the courier had just arrived. The men were ordered to leave, and there remained then only myself and four others. While I laid the safety-fuze to the magazine, Captain Pinckney tried in vain to burst the 10-inch columbiad and a 32-pounder, but owing to the vent-hole being filled with sand no friction-tube or priming would prove effectual. At length the time came for lighting the fuze. This I did with my lantern, watching it burn very well for fully twenty seconds, and having the officers with me to say they thought it fairly lighted. We then started on a double-quick for Battery Gregg, but had not gone halfway when I gave out, the shells still dropping around us, and was forced to walk slowly for some considerable distance.

When we came within about 200 yards of Gregg we heard the report of small-arms ahead of us, and gave up all for lost; but, picking our way forward, we were met by Major Bryan. He urged us to hasten, as the enemy's small boats were firing into ours, and threatened to cut us off every instant. Rushing into the water above the knee, I reached the last boat as it was in the act of shoving off. Hardly had we left Cumming's Point twenty yards when small-arms were opened furiously upon us, the bullets whistling all around our boats. Lieutenant W. H. Odenheimer of the navy, commanding our boat, steered her out to sea,



thus avoiding the enemy, or we would have been captured, as were three others of our boats. After a row of about ten minutes we were landed at Fort Sumter, and thence transferred to a steamer for the city, which we reached about 3 o'clock on the morning of the 7th of September.

T. A. HUGUENIN,

*Captain First South Carolina Infantry.*

SULLIVAN'S ISLAND, }  
 BEAUREGARD BATTERY, }  
 October 4, 1863. }

DEPARTMENT OF THE SOUTH, }  
 HEAD-QUARTERS IN THE FIELD, Sept. 7, 1863. }

MAJOR-GENERAL H. W. HALLECK, *General-in-Chief:*

GENERAL: I have the honor to report that Fort Wagner and Battery Gregg are ours. Last night our sappers crowned the crest of the counterscarp of Fort Wagner on its sea-front, masking all its guns, and an order was issued to carry the place by assault at 9 o'clock this morning, that being the hour of low tide.

About 10 o'clock last night the enemy commenced evacuating the island, and all but seventy-five of them made their escape from Cumming's Point in small boats. Captured despatches show that Fort Wagner was commanded by Colonel Keitt of South Carolina, and garrisoned by 1400 effective men, and Battery Gregg by between 100 and 200.

Fort Wagner is a work of the most formidable kind. Its bombproof shelter, capable of holding 1800 men, remains intact after the most terrible bombardment to which any work was ever subjected. We have captured nineteen pieces of artillery and a large supply of excellent ammunition. The city and harbor of Charleston are now completely covered by my guns.

I have the honor to be, general, very respectfully, your obedient servant,

Q. A. GILLMORE,

*Brigadier-General, commanding.*

*Report of Colonel L. M. Keitt.—Evacuation of Morris Island.*

CHARLESTON, S. C., }  
 Sept. 7, 1863. }

CAPTAIN: I have the honor to make the following report of the evacuation of Morris Island, including Batteries Wagner and Gregg, by the troops under my command, on the night of the 6th instant.

This step was authorized by a despatch sent by signals from district head-quarters, and received by me between 4 and 5 p. m., and directed in detail by a special order from department head-quarters, which was

received from Captain W. G. McCabe, of General Ripley's staff, at dark, and was necessitated from the untenable condition of Battery Wagner, the greatly exhausted condition of the garrison, and constant artillery and sharpshooting fire of the enemy, which prevented repairs. The gradual approaches of the enemy had passed the front of the battery, and the termination of their sap was not over fifty yards from the parapet of the sea-face, enabling them to throw a mass of troops upon this flank when our men were mostly in the bombproofs, where I was forced to keep them by the unceasing fire of mortars and rifled guns on land, with an enfilading fire from the fleet during most of the day. The salient on the left of the battery had been swept by such a terrible cross-fire as to breach the parapet and throw it into irregular shapes, rendering the ascent from the moat easy; and, moreover, men could not be kept there during this cross-fire without the certainty of most of them being wounded or stunned. This salient is the part of the work gained by the enemy in the assault of July 18th.

As soon as the evacuation was authorized, I gave detailed instructions to the regimental commanders—viz. Lieutenant-Colonel John G. Pressley, commanding Twenty-fifth South Carolina volunteers; Major James Gardner, commanding Twenty-seventh Georgia volunteers; Captain W. P. Crawford, commanding Twenty-eighth Georgia volunteers—for the gradual movement of their men to Cumming's Point, so as to keep up an effective front to the enemy and ensure silence and promptness. They expressed their hearty approval, believing an evacuation necessary to prevent a useless sacrifice of men. The men went down as if for special duty, and, though the most intelligent knew the fact, nearly all went off as if going to be relieved.

Captain Huguenin, chief of artillery, was promptly notified of the steps to be taken, and made his arrangements, with my sanction, for the removal of the artillery, and the written orders when received were submitted to him for his guidance. He was intrusted with the delicate duty of bringing up the extreme rear and firing the only magazine which contained powder, Lieutenant E. Mazyck, ordnance officer, being ordered to assist him. His report, with Lieutenant Mazyck's, is enclosed, marked A, and is referred to as an important portion of this report.

At dark, I sent to Captain H. R. Lesesne, who was commanding Battery Gregg, an order to prepare to blow up his magazine and render his guns unserviceable, directing him to confer with Captain F. D. Lee, of the Engineers, who had read the orders. I had no copy of the detailed order, which came late, to give him, which was thus not communicated to him. I refer you to his report, marked B, for particulars.

To anticipate the possibility of a pursuit by the enemy while retreating from Wagner, I ordered Lieutenant Robert M. Stiles, chief engineer at Battery Gregg, to construct a rifle-pit across the island at a narrow point about a quarter of a mile in advance of Battery Gregg. This was

accomplished by him after dark, while under mortar-fire, with a force of seventy-seven negroes in his charge. He also cut away most of the earth-covering of the magazine on the side toward our James Island batteries, then sent his negroes off to Fort Johnson, using a large flat left at Cumming's Point for that purpose.

Owing to the necessity of protecting the already reduced garrison, I had, early on the morning of the 6th instant, made the following disposition of my troops: The Twenty-seventh Georgia regiment, effective total 175 men, commanded by Major Gardner, a gallant and intelligent officer, were in the sand-hills, well protected in pits dug there, the hillocks being natural traverses. Fifty men of the Twenty-eighth Georgia, under Captain M. Adams, who had picketed the beach during the night, were also there; the remainder of the regiment, numbering 130 effectives, were assigned to the extreme right of Battery Wagner; about 45 kept out on the lines and the remainder in the bombproof. The Twenty-fifth South Carolina (Eutaw) regiment, which had been terribly reduced by casualties and sickness during the day and night preceding to an effective total of about 365 men, manned the left and centre of the battery, keeping only a guard of each company on its respective position of the lines, the remainder in the bombproof. Two companies of this regiment were sent to the sandhills for protection and to make room in the bombproof, where several men had fainted on the 5th from excessive heat and foul air. Major Gardner was ordered to cover the retreat with the Twenty-seventh Georgia in case of pursuit by the enemy; in the mean time, to picket the beach at dark and hold his reserve in readiness to support Battery Wagner.

At early dark, I ordered Lieutenant-Colonel Pressley, commanding Twenty-fifth South Carolina, a very intelligent and reliable officer, to detail four companies (about 100 men) to take a field-piece from the left curtain to Cumming's Point and embark on the first boats. Half an hour after, Captain Crawford, commanding Twenty-seventh Georgia volunteers, was ordered to move a howitzer from the right of Wagner to the rifle-pit near Gregg, place the piece in position there, collect his regiment, form line of battle in rifle-pits, and when notified that transportation was ready to send a company at a time to embark. Major Gardner was ordered to man the rifle-pits when Captain Crawford had left. Lieutenant-Colonel Pressley was ordered to extend his lines and cover the line manned by the Twenty-eighth Georgia as soon as that regiment started, which was promptly done by him. I will here remark that all this night, as on the previous night, the enemy threw a strong calcium light on the front of Battery Wagner.

About 9 P. M., being informed that transportation was ready, the embarkation commenced, and went on briskly and quietly until all had been embarked except the rear-guard, which was commanded by Captain T. A. Huguenin, numbering 35 men—25 men of the First South

Carolina [regular] Infantry (Company A) and 10 men of the Twenty-fifth South Carolina volunteers, under command of Lieutenants F. B. Brown and R. M. Taft.

At about 11 P. M. I turned over the command of Battery Wagner to Captain Huguenin, and, ordering my adjutant-general, Major H. Bryan (a member of General Beauregard's staff, who had volunteered for special duty on Morris Island), to accompany me, I proceeded toward Cumming's Point. At the rifle-pits I received information that more transportation was ready, and I immediately ordered Major Gardner to embark his regiment and to take with him the 12-pounder howitzer; which he did, but could not bring it off the island.

The transportation, under the direction of Major M. A. Pringle, post-quartermaster in Charleston, was admirably managed. Lieutenant-Colonel Dantzler, Twentieth South Carolina volunteers, having been specially detailed by General Ripley to superintend the transportation, under his spirited and excellent management it succeeded perfectly.

When the infantry were all embarked, I directed Captain J. T. Kanaux, commanding light artillery, to spike his three howitzers and embark his command. Captain Lesesne was then ordered to spike the guns of Battery Gregg and embark his men. The rear-guard from Wagner, coming up at this time, were embarked. I had ordered Captain Huguenin down, sending word by Private John A. Stewart, Gist Guards, the cavalry couriers having left without permission. There was no light kept at Gregg, so I could not well note the hour. With two or three boats I now anxiously waited for Captain Huguenin's party. Finally, perceiving that the enemy's barges from Vincent's Creek were attacking our boats with musketry, I ordered the safety-fuze to the magazine of Battery Gregg to be lighted; it was lit. The firing then ceased. As I desired the explosions at both batteries to be simultaneous as ordered, I ordered Captain Lesesne to extinguish the fuze, intending to relight it or apply another fuze when Captains Huguenin and Pinckney and Lieutenant Mazyck, who were the only persons who had not yet come to the point, arrived. Major Holcombe, who had lighted the fuze, immediately attempted to extinguish it. He informed me from the parapet of the battery that it would be difficult to cut it in twain, and that it was burning brightly. At that moment the absent party arrived, and I directed him not to interfere with the fuze, which was then burning brightly.

About 1.30 A. M., with the rear-guard of my command, I embarked, thus successfully withdrawing from Morris Island, and my responsibility ended. As we started off the Yankee barges directed their musketry-fire upon us, causing the bullets to whiz around us, but doing no harm.

Bearing toward Fort Sumter, I proceeded to flag-steamer Charleston, and notified Captain J. R. Tucker that the evacuation of Morris Island

was accomplished, and requested him to give the rocket signal to our batteries.

I then proceeded to district head-quarters and repeated the information, arriving at 3 A. M. on the 7th.

During the day and evening of the 6th, Captain J. E. Adger, the efficient post-quartermaster, kept his only wagon moving the wounded from Wagner to Gregg, under the direction of Chief-Surgeon William C. Ravenel. Strange to say, none were hurt by the enemy's fire, which from time to time swept across the road. Of course the wounded were embarked first.

Dr. Ravenel performed his arduous duties with alacrity and zeal, showing every kindness to the wounded and stunned, who poured in from sunrise on the 5th till the evening of the 6th. He left about 10.30, leading his ambulance corps.

I am happy to state that the majority of the wounds were slight, though disabling the men for the time.

The guns in the batteries were spiked and the implements generally destroyed; equipments mostly carried off. The magazines were not blown up, owing to the faulty character of the safety-fuzes used for the purpose, which were ignited—that at Battery Wagner by Captain Huguenin, assisted by Captain Pinekney, district ordnance officer; and that of Battery Gregg by Major Holcombe, under Captain Lesesne's instructions and the supervision of Captain F. D. Lee and Lieutenant Stiles of the Engineers.

The enemy were within thirty steps of the front of Battery Wagner; the voices of their sappers could be distinctly heard. Any attempt to break off the trunnion or shatter the carriage of a gun would have been distinctly heard and our movements discovered. Besides, the gun-chambers had been filled with loose sand displaced by the enemy's shot, and the guns could not be managed. I attempted to move the sand, but my working-parties were broken up as soon as put to work. The enemy had planted heavy mortars within 100 yards of the battery, and they could and did throw their shells into any designated spot. They could hear the movements of a party at work along the line, and would kill, wound, or disperse the men. Property had to be destroyed within thirty steps of the enemy, and while they could hear the voices of our men in this close proximity to them, the whole garrison had to be removed. Their land-batteries and fleet swept every inch of ground between Batteries Wagner and Gregg, and any suspicion of our movements compromised, if it did not destroy, the safety of the garrison. All the guns were effectually spiked.

At Battery Gregg everything was destroyed but the two 10-inch guns. They were prepared for bursting when the last party embarked. Before this party arrived the enemy's barges fired upon ours transporting our troops, and also turned their fire upon us.

An attempt had been made by the enemy in barges the preceding night to assail and capture Battery Gregg. The number of their barges then in easy range could not be ascertained.

I was informed by the engineer captain (Lee) that the explosion of the magazine would destroy the guns. The fuze was lighted, burned well, and no doubt was entertained of its igniting the magazine.

The rear-guard from Battery Wagner had embarked under fire from the enemy's barges. These barges, I am convinced, gave the enemy the information of the withdrawal of our garrison.

The guns of Battery Gregg were spiked.

My chief exertion was to save my men, whose future services will, I trust, be worth much more to the Confederacy than what I failed to destroy to the enemy. Had instructions been sent to me earlier, more might have been done.

Lieutenant Stiles, assistant engineer, stationed at Battery Gregg, at my request had come up to Battery Wagner in the morning. Upon examination, he expressed to me a doubt whether there was powder enough in the magazine to blow it up. I should state at this point that I had sent on Friday for an additional supply of powder, sending the requisition and my report as to the state of the garrison and of the day's proceedings by Major Warley, chief of artillery, who was wounded, and returned to the city in a small boat sent for the purpose. This boat was captured by the enemy's barges, and my report either taken or destroyed by Major Warley. Of this capture I had no knowledge until Saturday night. The blowing up of the magazines was intrusted by me to brave and intelligent officers, who I think did their best to effect it. (See Huguenin's and Lesesne's reports, marked A and B.) The chief ordnance officer of the district came to Morris Island apparently to look after this, and was given every facility he asked for.

I did not attempt to destroy the bombproof at Wagner, because, after consulting with Captain Lee of the Engineers, I deemed it impracticable from the small quantity of combustible material at my disposal, and because any smoke would at once inform the enemy and stimulate him to pursue us by land and water. It must be remembered that the sand above the bombproof was considerably saturated with water, which dripped through in several places.

To Captain Huguenin, chief of artillery; Major Bryan, assistant adjutant-general; Lieutenant-Colonel Pressley, commanding Twenty-fifth South Carolina volunteers; and Lieutenant-Colonel Dantzer, superintending embarkation, I am chiefly indebted for the success of the evacuation.

My thanks are due Mr. J. F. Mathewes, Engineer corps, for the use of his boat and crew for moving troops and bringing me off at the last.

Captain J. R. Haines and Lieutenants H. Montgomery, Jr., and R. A. Blum of the Twenty-fifth South Carolina volunteers, three valuable

officers, were killed at their posts of duty during the last of the siege. Let their names be honored.

I desire to record the faithful services of Privates J. M. Leathe, J. A. Stewart, and John H. Bond of the Gist Guards, South Carolina volunteers, who have remained voluntarily on duty at Battery Wagner almost the entire siege, always attentive and cool under fire. Stewart would make an excellent commissary and Leathe a practical and hard-working ordnance officer.

Lieutenant R. M. Stiles, Engineer corps, creditably performed the duties assigned to him. Lieutenant Robert S. Millar, Company A, Second South Carolina Artillery, was distinguished for courage and for his cheerfulness, which was not diminished by a slight wound on the knee and by being stunned for half an hour.

To Major Bryan of General Beauregard's staff, who volunteered as my adjutant-general, I am under the greatest obligations. Although at the time I was ordered to Morris Island to assume command of the forces there he had a furlough to visit his father in Georgia, who was very ill, he promptly waived it and volunteered to go with me. His tact, coolness, experience, courage, and untiring industry were of the greatest service to me during the night and the day. His vigilance extended to every department and perpetually sought out means of increasing our resources and supplying our deficiencies.

In spite of severe indisposition for several days, I have made every exertion to meet the very unusual responsibilities imposed upon me.

Taking all circumstances into consideration, I trust that this will not compare unfavorably on the part of the garrison with any other retreat made during this war.

I am, sir, very respectfully, your obedient servant,

LAWRENCE M. KEITT,

Captain W. F. NANCE, *Colonel, commanding.*  
A. A.-G. 1st Mil. Dist., Dept. S. C., Ga., and Fla.

[Indorsement.]

HD-QRS. DEPT. SOUTH CAROLINA, GEORGIA, AND FLORIDA, }  
CHARLESTON, S. C., September 19, 1863. }

Had this evacuation been conducted in strict compliance with detailed orders, it would be one of the most memorable in history, and, after all, may be regarded as a signal success and highly creditable to the commanding officer and all officers and men who participated in it. Subjected to a terrible fire, and beleaguered almost to the very ditch of the work by an enterprising, watchful adversary, yet the entire garrison was withdrawn in safety. The coolness and discipline which characterized this operation, and through which an efficient command has been saved to the country for future use, are deemed worthy of notice and commendation by the War Department, especially when taken in connection

with their stout defense of Morris Island for four days preceding the evacuation, together with the limited and imperfect means of water transportation at command.

One of the reasons assigned for not bursting the guns, blowing up the magazines and bombproofs in Batteries Wagner and Gregg—that is, an alleged want of time after the order to evacuate had reached Morris Island—calls, however, for remarks from these head-quarters. It had been a standing order for several weeks previous to the evacuation that in such an event all guns, magazines, bombproofs, etc. should be thoroughly destroyed, and with that view time-fuzes had been tested, and, with rat-tail files, were provided for both works. Further, the written special instructions of Brigadier-General Ripley, prescribing measures and means for the complete destruction of these works and of their armaments at the proper time, and the detailed orders directing and regulating the evacuation of Morris Island, were received by the commanding officers at dark on the 6th instant (about 6 P. M.). The last detachment of his command did not quit the island until after 1 A. M. on the 7th instant; hence, there were seven hours for the completion of all necessary arrangements. I am, therefore, unable to admit that there was any lack of time for the thorough execution of the work of destruction ordered. It is not explained why the time-fuzes failed to explode the powder left in the magazines. They were seen burning brightly when last observed, and it is therefore probable that either before or while the fire was being applied the ends in contact with the powder were accidentally detached.

G. T. BEAUREGARD,  
*General, commanding.*

*Report of Captain T. A. Huguenin, commanding Rear-guard in  
Evacuation of Morris Island, September 6, 1863.*

CHARLESTON, S. C., }  
Sept. 7, 1863. }

MAJOR: I have the honor to make the following report of the duties assigned to me when evacuating Morris Island last night:

As soon as orders were received for the evacuation, I was intrusted by Colonel Keitt to command the rear-guard, with the following instructions: To hold Battery Wagner, with a forlorn hope of 35 men, until he had embarked the remainder of the garrison at Cumming's Point, when he would send me word to that effect, and I would then withdraw my men with as little delay and noise as possible, after destroying the guns and laying a slow-match to the magazine. The orders detailing the manner of evacuation and destruction of property did not arrive until some time after dark. Immediately upon the receipt of the orders I commenced preparations. The inclosed paper, marked A, was presented to Colonel Keitt and approved.



About 8 P. M. the 10-inch mortar was fired, and firing kept up until a short time before the final evacuation. I then relieved Captain J. D. Johnson's, a portion of Captain W. M. Hunter's, and a portion of Captain J. T. Kanapaux's companies, who immediately commenced the retreat. I then visited the batteries that were not manned, and commenced the destruction of such implements as my limited time would permit.

At 11 P. M. my support, under command of Lieutenant-Colonel J. G. Pressley, withdrew, together with the guard. I then posted my artillery, who were now firing at long intervals, as sharpshooters along the whole fort, with orders to keep up as continuous a fire of small-arms as is usual at Battery Wagner during the night, the enemy all this time keeping up a furious bombardment from mortars and rifled guns.

At 11:30 P. M. I ordered the relief of Lieutenant Millar's and Captain Kanapaux's detachments. The whole garrison of the fort then consisted of 25 men of Company A, First South Carolina Infantry (regulars), and 10 men from the Twenty-fifth South Carolina volunteers. The firing of our sharpshooters was increased, in order to deceive the enemy as to our movements.

At 12:30, or near about that time, I commenced relieving the rear-guard, commencing on the right, and, with Captain Pinckney, carefully spiking every gun except the 10-inch columbiad, which was double-charged and prepared for bursting. By the time this was done and the rear-guard was ready to move, a courier arrived from Cumming's Point with orders from Colonel Keitt to complete the evacuation, as the troops had all left and transportation for the rear-guard was ready. I immediately withdrew my sharpshooters from the parapet, and started the rear-guard to Cumming's Point. Captain Pinckney, ordnance officer, First Military District; Lieutenant Mazyek, ordnance officer, Battery Wagner; Lieutenant James A. Ross, Twenty-fifth South Carolina volunteers; and Ordnance Sergeant Leathe and myself, alone remained to lay the slow-match, which had been prepared in the early part of the night. In about five minutes the train was fixed, and the 10-inch columbiad was attempted to be fired. Four friction-tubes failed, and powder was gotten from the magazines and the vent primed as well as possible. The implements having been destroyed, according to instructions from district headquarters, again it was attempted and failed. Preparations were then made to burst the 32-pounder, which bursting of a gun was the signal to Colonel Keitt that the evacuation was completed. But this failed also, after several attempts. The rear-guard had then been gone fifteen or twenty minutes, and the enemy having slackened their fire a little upon Wagner and commenced firing on Cumming's Point and between the two batteries, I thought that perhaps they had discovered our intentions; and, knowing that Colonel Keitt and the remainder of the garrison at Battery Gregg and the rear-guard would be waiting for me, I, in

order to preserve them from danger, abandoned the idea of bursting the 10-inch columbiad, and immediately, with my own hands, applied the match to the safety-fuze. It ignited, and I remained and saw it burning for fifteen or twenty seconds, apparently fairly and successfully ignited. Believing that I had done everything that could possibly be done, I commenced my retreat, arriving at Battery Gregg during the fire of the mortars and rifled guns on Morris Island and the firing of small-arms from the enemy's boats near that point.

In justice to myself, I desire to state I had taken command of the artillery at Battery Wagner under a heavy bombardment, which continued until after I left, and therefore my duties in the batteries were such as to prevent my giving the proper attention to every matter of detail, as I would have done under other circumstances. I feared the slow-match would not answer, and I applied to Colonel Keitt to be permitted to set fire to the bombproof with three barrels of rosin, but he refused, upon the ground that the instructions stated distinctly that the fire was to be communicated by slow-match, upon the advice of the Engineer officer that the smoke and fire would make known our intentions to the enemy.

In conclusion, I am happy to state that the rear-guard behaved with perfect coolness. They were marched from Battery Wagner in perfect order by the second officer of the guard, Lieutenant F. B. Brown, Twenty-fifth South Carolina volunteers.

From the continued firing of the enemy, I am inclined to believe that the enemy did not discover that the evacuation had taken place until the last boatload had reached Fort Sumter.

Inclosed you will find a copy of Lieutenant Mazyck's (ordnance officer) report, to whom I am much indebted for his valuable services.

I have the honor to be, very respectfully, your obedient servant,

T. A. HUGUENIN,

*Captain First S. C. [regular] Inf. [3d Art.], Chief of Artillery.*

Major HENRY BRYAN,

*Assistant Adjutant-General.*

*Report of Captain C. C. Pinckney, C. S. Artillery, Ordnance Officer  
First Military District.*

HEAD-QUARTERS FIRST MILITARY DIST. OF S. C., ORD. DEPT., }  
CHARLESTON, S. C., September 8, 1863. }

GENERAL: In obedience to your instructions, I have the honor to submit the following statement of what passed under my observation at Battery Wagner on the night of the evacuation of that post:

On the evening of that day I took down some spikes, slow-match, safety-fuze, sledges, etc. to Morris Island. I went at once to Battery

Wagner, taking the spikes in my hand. I had made requisition for rat-tail files in August last, but had received none. These were intended as substitutes. I found Captain Huguenin with the ordnance officer, Lieutenant Mazyck, arranging the safety-fuze previously sent, and gave them my assistance. The splicing was carefully done, the ends of the fuze split and pinned. Captain Huguenin stated that he had tried several pieces of the fuze, but I repeated the experiment and found it burned perfectly well. When the main body of the garrison was withdrawn, I remained to assist in the final dispositions. The proper time having elapsed, Lieutenant Mazyck, assisted by Lieutenant James A. Ross, Twenty-fifth South Carolina volunteers, was left to lay the fuze, and I, accompanied by Captain Huguenin, to spike the guns. Here we encountered great difficulty. The vents of most of the pieces were greatly enlarged. In many cases the spikes dropped loosely in, and we were obliged to use two and sometimes three of them. We could have remedied this in a measure had it been practicable to drive them tightly and hammer the edges of the orifice over them, but Captain Huguenin's order enforced the most perfect quiet, and the necessity was sufficiently obvious. We obviated the difficulty as well as it was possible by bundling up a haversack and hammering through that, but it could not be thoroughly effective. Having thus spiked each piece in succession, excepting the 10-inch columbiad, Captain Huguenin arranged a lanyard for firing this gun, the wheels being in gear, and we returned to the magazine. The cartridges (a large number) were piled up against one wall and the fuze inserted in one of them, going down to the bottom, and carefully trained out of the door and along the side of the covered way, to avoid the feet of any passers-by. We then waited the courier from Colonel Keitt, Lieutenant Ross and myself, by Captain Huguenin's orders, joining the lookouts in firing an occasional rifle from the parapet to keep up a show of occupation. The courier came. Lieutenant Ross then took the lanyard and Captain Huguenin ordered, "The last gun from Battery Wagner, fire!" But the primer failed. Another gave no better result. We then primed with powder from a Whitworth rifle cartridge, but the piece could not be fired. We then got out one of the two spikes from the 32-pounder, but the other prevented the passage of the flame. So much time was now consumed that Captain Huguenin thought best to abandon the attempt. He lit the fuze, all of us watching to see that it was burning correctly. We then abandoned Battery Wagner. Great was our disappointment as we looked in vain during our passage to the city for the expected explosion. Possibly a fragment of shell may have cut the fuze before it burned to the door. I can think of no other accident; no precaution was omitted.

Though not officially present, I trust I may be allowed as a spectator to bear witness to the coolness, judgment, and fidelity of Captain

Huguenin and the officers under him in the discharge of the delicate task confided to them.

I have the honor, general, to be, very respectfully, your obedient servant,

C. C. PINCKNEY,

*Captain Artillery and Ordnance Officer First Mil. Dist., S. C.*

Brigadier-General R. S. RIPLEY,

*Commanding First Military District, South Carolina.*

*Report of Captain H. R. Lesesne, First South Carolina Artillery.—  
Assault on Battery Gregg and Evacuation.*

CHARLESTON, S. C., September 7, 1863.

MAJOR: I have the honor to report that in obedience to orders received from Colonel Keitt I went to Battery Gregg on the morning of the 5th instant and took command of the post. The battery was shelled heavily during the day by the enemy's land-batteries, and for a part of the day by the Ironsides, causing considerable injury to the work and a number of casualties: I am not able to state the exact number. Information having been received that the enemy intended an attack by water on the battery, I had the guns of the battery trained on the most probable points of attack, double-loaded with canister, one 10-inch columbiad bearing on the beach in front and one on the extreme point in rear. Two 12-pounder howitzers were placed on the beach to the right of the work, running from the right of Battery Gregg to the beach. The artillery was supported by Major Gardner, commanding the Twenty-seventh Georgia.

About 1.30 A. M. the enemy advanced upon the point in about twenty boats; when within 100 yards of the beach I opened upon them with the 10-inch gun, followed by the howitzers. The infantry commenced firing shortly afterward. The enemy returned the fire with their boat-howitzers and musketry. A few succeeded in landing, but quickly returned to their boats. After the fire had been kept up for about fifteen minutes the whole force retired.

Our casualties were 1 man mortally and about 5 slightly wounded. The enemy's loss is not known, but it is supposed to have been heavy.

The fire of the enemy was kept up steadily on the 6th until evening, material damage being done to the work. Casualties, 7.

Having received orders about 7.30 P. M. to hold myself in readiness to evacuate the work, spike the guns, and blow it up, with the assistance of Captain F. D. Lee and Lieutenant Stiles of the Engineers I laid the safety-match in loose powder in the magazine, running it out to the parapet of the work. The match was laid on planks, so as to prevent any moisture from reaching it. The men composing the garrison of the battery were embarked immediately after the last of the Twenty-seventh

Georgia. On receiving orders from Colonel Keitt, I spiked the two 10-inch guns, breaking the spikes flush off with the guns; had the field-pieces spiked and thrown overboard, with all their ammunition; and directed Major Holcombe, commissary of subsistence, who had volunteered to assist me, to light the match. The match went out at first, but on being lighted again burned well. On Colonel Keitt's countermanding the order for lighting, it was found impossible to extinguish it, and it could not be cut with the knife which we had. This was but a few minutes before we left the point, and it was then within the doorway of the magazine and burning freely. I omitted to mention that the match was cut off to burn about fifteen minutes, it burning a foot in fifteen seconds.

Very respectfully, your obedient servant,

HENRY R. LESESNE,

*Captain First South Carolina Artillery.*

Major HENRY BRYAN,

*Assistant Adjutant-General.*

*Naval Attack on Sullivan's Island.*

HEAD-QUARTERS FORT MOULTRIE, S. C., }  
September 9, 1863. }

SIR: I have the honor to report that yesterday morning, 8th instant, one of the monitors (the Weehawken) was observed to be aground opposite this post, and fire was at once opened on her with effect, many of our shots having been seen to strike the hull, of which a large portion was exposed by the lowness of the tide. The steamer promptly replied, and soon brought to her assistance the Ironsides and five monitors. At about 8 A. M. the Ironsides came to anchor about 1200 yards from the fort, and the monitors took their position higher up the river and at about 1800 yards, and together opened a terrific fire from rifled and XV-inch guns, using shot, shell, shrapnel, grape, and incendiary shell.

I regret to announce here an accident most terrible in its effect, and but for which our casualties would have been but slight. A XV-inch shell from the Weehawken struck the muzzle of an 8-inch columbiad, and, glancing off, exploded among a number of shell-boxes and ammunition-chests which had been placed behind a traverse (and at which a number of the men of Captain Smith's company were stationed), killing instantly 16 men and wounding 12 others. Captain R. P. Smith, Jr., himself narrowly escaped by leaping from the parapet into the ditch in front of the fort.

The fire from the enemy now became furious, and broadside after broadside from the Ironsides would tear through the buildings of the fort, sending fragments of every description in every direction, and

rendering it almost impossible to pass from one portion of the fort to another; but nobly did officers and men remain at their guns and return their fire. Captain Burnet's company came from the Beauregard Battery under a storm of shot and shell and relieved Captain Smith, whose men had been nearly all killed or wounded by the explosion already mentioned.

Lieutenant D. G. Calhoun deserves great credit for the manner in which he discharged his duties as officer of the day in carrying out the arrangements for the removal of the dead and wounded, and frequently in extinguishing fires in different parts of the fort during the most severe part of the bombardment.

Captain G. A. Wardlaw, assistant quartermaster, volunteered his services at one of the guns, and was conspicuous for his coolness and the manner in which he handled his piece, but was himself knocked down by a piece of one of the traverses, which, fortunately, inflicted no other damage than a momentary unconsciousness and some slight bruises.

Lieutenant D. B. DeSaussure while gallantly fighting his gun was struck by a large fragment of stone, which fractured his collar-bone and, it is feared, inflicted some internal injury.

Our fire was kept up steadily until 2 P. M., when the enemy withdrew, and one of the monitors, being evidently damaged, was towed out by two others.

The fire from the fort was deliberate and remarkably accurate, nearly every shot striking the boat at which it was aimed.

As I cannot mention any one more conspicuous for gallantry than another, I must content myself with simply saying that officers and men did their whole duty, and submit the names of the officers and companies engaged. The battery on the east was commanded by Captain Jacob Valentine, Company G, with Lieutenant DeSaussure; the battery next on the west was commanded by Captain B. J. Witherspoon, Company C; and the next battery by Captain R. Press Smith, Jr., Company E, with Lieutenants D. G. Calhoun and E. C. Edgerton, and afterward by Captain B. S. Burnet, Company F, with Lieutenants W. D. Gaillard, E. M. Whaley, and William J. Marshall.

Lieutenant L. W. Perrin rendered very efficient services as ordnance officer, and Surgeon Flournoy Carter and Assistant Surgeon E. H. Kellers assiduously supplied the demands of the wounded.

Two of the guns of the fort were placed *hors de combat*—the one an 8-inch columbiad, already referred to, and the other a rifled 32-pounder, the trunnion of which was knocked off by a piece of shell.

About 1 o'clock this morning, on the signal that an attack was being made on Fort Sumter, we again opened fire with shell and grape, firing so as to pass close to the right and left of the fort, and on a signal of "All right!" again ceased firing.

I have the honor to submit herewith a report of the casualties, the

number of wounded being far smaller than was at first reported, many of the wounds being slight and the men returned to duty :

Command, etc.	Killed.	Wounded.	Total.
Company C, Captain B. J. Witherspoon:			
Non-commissioned officers . . . . .		2	2
Enlisted men . . . . .	2	9	11
Company E, Captain R. Press Smith, Jr.:			
Non-commissioned officers . . . . .	1	1	2
Enlisted men . . . . .	14	11	25
Company F, Captain B. S. Burnet:			
Enlisted men . . . . .		1	1
Company G, Captain J. Valentine:			
Commissioned officers . . . . .		1	1
Enlisted men . . . . .	1	2	3
Total . . . . .	18	27	45

All of which is respectfully submitted.

Very respectfully, your obedient servant,

ROBERT DETREVILLE,

Lieutenant M. KING,

*Major, commanding.*

*Acting Assistant Adjutant-General.*

*Engagement with the Forts in Charleston Harbor.*

FLAG-STEAMER PHILADELPHIA, }  
OFF MORRIS ISLAND, September 8, 1863. }

SIR: I have already informed you, by express despatch, that the enemy evacuated the whole of Morris Island yesterday morning, just previous to an assault. I immediately designed to put in operation a plan to capture Fort Sumter, and, as a preliminary, ordered the Weehawken to pass in by a narrow channel winding about Cumming's Point, so as to cut off all communication by that direction. In so doing the Weehawken grounded, and, though at low water, did not succeed in floating at the next high tide.

Late in the day, at the proper time, I went on board the Ironsides, and moved up with the iron-clads to feel, and if possible pass, the obstructions north of Sumter. Moultrie and Batteries Bee and Beauregard quickly opened on us, and soon experienced a severe fire from our vessels, which was continued until I deemed it best to give entire attention to the Weehawken. Steam-tugs and hawsers were provided amply, but at the high tide of this morning did not succeed in floating her. About 7 A. M. the enemy perceived her condition, and began to fire from Moultrie, about 2000 yards distant. I ordered up the iron-clads to cover the Weehawken, which, meanwhile, gallantly replied, and in

less than an hour's firing blew up one of the enemy's magazines, which was recognized by a cheer from the men of our vessels near me. Some movement in Sumter seemed to draw attention from the Weehawken, which, with a few well-directed shells, settled that business.

Captain Colhoun has, in my opinion, more than compensated for the misfortune of getting aground by the handsome manner in which he has retorted on the adversary and defended the glorious flag that floats above him. At 11½ A. M. I telegraphed to him: "Well done, Weehawken! Don't give up the ship." We may lose the services of this vessel—I hope not—but the honor of the flag will be maintained.

It is proper to say that the iron-clads have been navigated under the most disadvantageous circumstances. They really have not had pilots. Mr. Godfrey has left us, and Mr. Haffords fell off the turret at night, being the only real pilots in this squadron. The monitors have been aground several times in action, and it is surprising that some of them have not been lost.

I have the honor to be, very respectfully, your obedient servant,

J. A. DAHLGREN,

*Rear-Admiral, commanding S. A. B. Squadron.*

Hon. GIDEON WELLES,

*Secretary of the Navy, Washington, D. C.*

P. S.—6. P. M. I am happy to say that at high water the Weehawken was gotten off. I commend Captain Colhoun, his officers, and crew to the notice of the Department. The crews of the other vessels cheered spontaneously as he passed.

J. A. D.

*Report of the Commander of the Monitor Weehawken, ashore and engaged September 8, 1863.*

U. S. IRON-CLAD WEEHAWKEN, }  
OFF FORT WAGNER, September 9, 1863. }

SIR: On the 7th inst., in obedience to your order, I proceeded with the Weehawken to buoy out the channel inside the buoy off Fort Wagner, in the direction of Cumming's Point. After passing the buoy off Wagner about 200 yards, I dropped a buoy in seventeen feet of water, and again, 400 yards farther on, a second one in fifteen feet of water, steering up nearly midway between Cumming's Point and Sumter. I anchored at 8.30 A. M. about 300 yards from the last buoy, it being then nearly low water. At 9.30 A. M. she swung to the flood-tide, and the channel being narrow, she touched bottom very lightly in eleven feet of water. When the tide had risen sufficiently to float her, I got under way, in obedience to your order, to "return to my anchorage near the New Ironsides;" but in consequence of the shoal water she steered very



badly; taking a "rank sheer" to port, she brought up on the bank in eleven feet water. In the afternoon, at high water, I failed to get her off, as also on the following morning, though every effort was made by taking coal and shot out, with one tug to assist us. At 8.30 A. M. (8th September) Fort Moultrie opened on us, the lower part of the overhang on the port side being then nearly out of water. As we lay upon the bank Fort Moultrie was nearly on our port beam. She fired slowly and deliberately at first to get the range, aiming under the overhang; then with rapidity, followed by other batteries on Sullivan's Island. This I had expected, and was ready for. I had been on deck from early in the morning, and had given orders to let the men sleep after their hard work during the night. We opened in a few minutes on Moultrie. The second shell from the XV-inch gun exploded a magazine to the left of the flagstaff, and she was silent for some time. When the Ironsides and monitors engaged the batteries they ceased firing at us. I then sent the men to breakfast, and after they had finished opened on Sumter. When the Ironsides and monitors withdrew from action they left the Weehawken alone.

I then made my preparations to get afloat at high water in the afternoon, and succeeded, though under a heavy fire from Sullivan's Island and Battery Simkins on James Island. I had three men wounded by a shot from Battery Bee, striking on the top of the turret, breaking the plating and railroad iron—one, John O'Grady, ordinary seaman, severely in the left thigh. I enclose herewith Assistant Surgeon E. M. Stein's report. We were hit twenty-four times, doing no material damage. One shot struck the lower part of the overhang, passed under, made a hole about three inches in diameter, and fractured the iron from the angles. The leak was soon stopped. We fired at Moultrie and Bee 36 shell; at Sumter, 46; total, 82.

The officers and men under my command deserve the highest praise for their behavior. Such a measure of endurance, patriotism, and valor as I have seen exhibited since I have been in command assures me they cannot be excelled.

Very respectfully, etc.,

EDWIN R. COLHOUN,  
*Commander.*

Rear-Admiral J. A. DAHLGREN,  
*Commanding, etc.*

[The injuries received required sixteen days for repairs. It is impossible not to admire the fine conduct and resolution of this commander and his crew. Their grounding was first noticed by Major Elliott from Fort Sumter, and signalled to Fort Moultrie; but the firing was limited by the bursting of the VII-inch Brooke rifle at Moultrie, though maintained by Battery Bee. Yet it seems not to have been efficient enough.

So Major Elliott complained. I have always wondered why the Weehawken did not fall an easy prey to the fire of Battery Simkins.—J. J.]

*Actions of the Iron-clad Fleet with the Works on Sullivan's Island  
on the 7th and 8th of September, 1863.*

HEAD-QUARTERS ARTILLERY, }  
SULLIVAN'S ISLAND, Sept. 12, 1863. }

CAPTAIN EDWARD WHITE, A. A.-G.:

SIR: I have the honor to make the following report of the actions between the batteries on this island and the iron-clad fleet of the enemy on the 7th and 8th of this month.

On the afternoon of the 7th, about 6 P. M., five monitors and the frigate Ironsides engaged the batteries until after dark, resulting in one casualty at our batteries. First Lieutenant E. A. Erwin was killed by a shell at Beauregard Battery. Lieutenant Erwin had just returned from service on Morris Island, and escaped unhurt to meet death at a less exposed position. He was more than ordinarily intelligent, brave, and conscientious. The regiment has lost in him one of its best officers.

The Ironsides continued to fire an occasional shot after we had ceased firing, until about nine o'clock P. M. It was, however, so dark that the vessels could not be seen.

On the morning of the 8th one of the monitors, supposed to be the Weehawken, which had the day previous taken a position very near the beach of Morris Island, in the channel leading to Cumming's Point, nearly opposite to Fort Moultrie, was observed to show so much of her hull as to lead to the belief that the boat was aground. I received also, early in the morning, a despatch from Major Elliott, commanding Fort Sumter, giving his belief that the boat was aground and could be destroyed. Learning from a conversation with Brigadier-General T. L. Clingman, commanding Sullivan's Island, that it would meet with his sanction, I directed a slow fire to be opened upon the monitor from the treble-banded Brooke gun and 10-inch columbiads—I think with some effect. The fire was returned, and about nine o'clock A. M. five other monitors, with the Ironsides, were seen approaching—whether to shield the boat that was thought to be aground, or whether it was a preconcerted move, I am unable to say. About this time a shell from the Weehawken struck the muzzle of an 8-inch columbiad in Fort Moultrie, and glanced into some shell-boxes which were protected by a traverse, producing an explosion, killing sixteen and wounding twelve men of Company E, First South Carolina Infantry, Captain R. Press Smith. This disaster rendered it necessary to replace Company E by Company F, Captain Burgh S. Burnet, which arrived under fire from Beauregard Battery.

The Ironsides took a position some 1500 yards distant, and opened a very heavy fire from her broadsides. The monitors took positions varying from 900 to 1400 yards, all directing their fire upon Fort Moultrie and the batteries adjoining. Batteries Bee and Beauregard also received a portion of their fire. The batteries replied, but, owing to the scant ammunition on hand, the fire was not so rapid as that of the fleet. After the action had continued about five hours the fleet withdrew, one of the monitors I think disabled, the Weehawken remaining in the same position it occupied this morning.

Besides the loss produced by the explosion before referred to, three men were killed; two officers—Captain G. A. Wardlaw slightly, and Lieutenant D. B. DeSaussure severely—and fourteen men wounded at Fort Moultrie.

At Battery Bee one officer and one man were slightly wounded, and at Battery Beauregard one officer, Lieutenant Edward W. Macbeth, slightly wounded.

Two guns in Fort Moultrie were disabled—the 8-inch columbiad before referred to, and one rifle 32-pounder. No other material damage was done to the batteries.

I regret to say that the treble-banded Brooke gun gave way during the action, a crack being made in the band in rear of the vent and through the breech. I beg leave to refer to the report of Lieutenant R. Y. Dwight for an explanation of the circumstances attending the loss of this valuable gun.

The firing at the several batteries on the island was accurate and deliberate, and it affords me great pleasure to commend the conduct of both officers and men of my command.

I enclose herewith the reports of battery commanders, with a list of killed and wounded.

I have the honor to be, very respectfully, your obedient servant,  
 WM. BUTLER,  
*Colonel, commanding.*

*Union Reports of Naval Assault on Fort Sumter.*

FLAG-STEAMER PHILADELPHIA, }  
 OFF MORRIS ISLAND, September 11, 1863. }

SIR: The Department is already informed that on the night of the 6th the enemy evacuated Morris Island, leaving it in our possession. This offered an opportunity for assaulting Fort Sumter, which was well broken on the gorge and south-east faces, and, if successful, would enable me to pass the obstructions in the main channel.

I therefore directed a party of volunteers to be called for, which was done, under the following officers, viz.: Commander T. H. Stevens,

Lieutenant Moreau Forrest, aide; Lieutenant-Commander E. P. Williams, commanding first division; Lieutenant G. C. Remy, commanding second division; Lieutenant S. W. Preston, commanding third division; Lieutenant F. J. Higginson, commanding fourth division; Ensign C. H. Craven, commanding fifth division; Lieutenant-Commander F. M. Bunce, Lieutenant E. T. Brower, Ensign James Wallace, Ensign B. H. Porter, and Ensign C. H. Craven. Also, the following officers of the marine corps: Captain C. G. McCawley, First Lieutenant Charles H. Bradford, First Lieutenant John C. Harris, Second Lieutenant R. L. Meade, Second Lieutenant Lyman P. Wallace, and Second Lieutenant L. E. Fagan.

Commander Stevens was appointed to command the whole detachment. On making a request to General Gillmore for some boats, I learned that he also contemplated an assault the same night. It was late in the evening before all the arrangements were made, particularly the concert with the detachment from the army, which was chiefly due to the want of competent signal officers. It was about 10 o'clock when the boats, in tow of a tug, started up the main channel, and had hardly approached Sumter when the sound of musketry announced the attack. This did not last long, and was followed by shell, etc. from Moultrie. Before I could reach Sumter the conflict had ceased. It was next morning before I learned positively that our party had been repulsed with considerable loss. Of 400 men, I learned by flag of truce that 130 are prisoners; by our accounts, 104 men and 10 officers are prisoners, and 3 men are killed. . . .

Hon. GIDEON WELLES,  
*Secretary of Navy, etc.*

J. A. DAHLGREN,  
*Rear-Admiral, etc.*

. . . . "About midnight we cast off from the Daffodil, and directly after Captain Stevens hailed and ordered me to pull for Fort Sumter. I did so, and while pulling Captain Stevens ordered me to follow the boat on my starboard bow, telling me she was going behind the fort. I followed the boat as directed, and passed the side of Fort Sumter which faces Fort Moultrie. Discovering a steamer coming from behind the fort, the leading boat went in close under the walls. We followed her, and pulled back toward the sea-face, examining the foot of the fort to see if any of our boats had landed. Upon coming to the right bastion of the sea-face (the eastern angle), I found the marines in boats firing at the fort. I could find no officer to report to regarding the steamer, and no one could tell me whether our men had landed or where they were. Seeing a boat sinking, I pulled toward it, but found that all of its men had been taken out or drowned. . . . The interval from the time the first gun was fired until the order to retreat was given was about twenty minutes, the enemy using small-arms and hand-grenades.

Almost all the marine boats and a great many boats with sailors in them replied to the enemy's fire with their muskets and revolvers." . . .

JAMES WALLACE,

*Ensign, commanding Naval Battery.*

Rear-Admiral J. A. DAHLGREN,

*Commanding, etc.*

MARINE BATTALION.

. . . . "No one in our boat or the Housatonic's heard the order 'Pull for Sumter' (which I have understood was passed around). We were completely at a loss what to do. . . . I pulled for the Philadelphia to report for orders. You then sent for me to come on board. . . . Scarcely had I got in my boat when I saw two or three quick flashes of light (musketry), by which I found we were but a few hundred yards from Sumter. Before I could say 'Cast off,' almost, the men were pulling lustily and in great spirits for the fort. We closed in rapidly among the other boats, and got into the thick of the fight, when Moultrie and the other batteries opened. Every boat left us; the call all around was 'Cease firing and draw off,' and, disgusted anew, we did so. After we got out a little I reconnoitred our position, and found the stampede was increasing and no boats on the ground. . . . Throughout I could see nothing but the utmost confusion." . . .

JOHN C. HARRIS,

*Second Lieutenant U. S. Marines.*

Rear-Admiral J. A. DAHLGREN,

*Commanding, etc.*

MARINE BATTALION.

. . . . "I was in charge of a detachment of 6 officers, 6 sergeants, 8 corporals, and 86 privates, and reported myself and command to Commander T. H. Stevens. . . . I was instructed to keep my command in the rear, and not to land until the sailors had done so—to fire on the enemy from our boats and cover the landing, and as soon as they got in to cease firing, land ourselves, and use the bayonet. . . . We were soon discovered, and the fire began from the loopholes and parapet. This my men returned briskly, until a cry arose of 'Cease firing!' Presuming that our sailors had landed, I called to the boats to cease firing and land, but, to my great surprise, saw them all immediately turn and pull away after the crowd of others which were going out.

"I called in vain to stop, and followed as fast as I could until I found that the leading boat was that of Captain Stevens (?), which Mr. Craven hailed and threatened to fire into, until informed whose it was. We asked what we were to do, and were told to go to the Daffodil. . . .

"I find 2 lieutenants, 2 sergeants, 2 corporals, and 25 privates are missing, probably in the hands of the enemy, and 1 private wounded on

board the Memphis. It was very dark near the fort, and there was great confusion."

C. G. MCCAWLEY,  
*Captain U. S. Marines.*

Rear-Admiral J. A. DAHLGREN,  
*Commanding, etc.*

*Major Elliott's Report of Naval Assault on Fort Sumter.*

HEAD-QUARTERS, FORT SUMTER, }  
 September 12, 1863. }

CAPTAIN: I have the honor to submit a report of the late action at this post.

On the 4th instant, pursuant to Special Orders No. 298, head-quarters First Military District, Department of South Carolina, Georgia, and Florida, I assumed command, with the Charleston battalion of infantry (commanded by Major J. A. Blake) as a garrison. All the available guns having been already dismounted, the defense was to be conducted by infantry.

The condition of the work was as follows: The gorge A had been so cut by the enemy's artillery that the scarp had assumed the form of an inclined plane with a dip of about 45°. The wall of the east face had been shot away, leaving the arches (which had been filled with sand) exposed. The north-east face was comparatively secure. The north-west contained several serious breaches, and one of very considerable size, B. This was defended by a barricade. The others were securely obstructed. The west face was uninjured, the lower tier of embrasures being merely closed by their usual shutters. The main sally-port in this face had been pierced for musketry and commanded the wharf.

Dispositions similar to the following were habitually made: Captain J. W. Hopkins's company (D), 43 men, lay on their arms on the parapet of the gorge, and Captain F. T. Miles's company (E), 12 men, at the breach in the north-west face. The guards, excepting the sentinels on post, were to defend the sally-port. Captain T. Y. Simons's company (B), 28 men, lay at the entrance on the west face. In case of an alarm, Captain S. Lord's company (F), 42 men, was to occupy the south-west angle and support Captain Hopkins on the right. Lieutenant J. C. Sallatus's company (A), 12 men, at the south-east, was to support him on the left. Lieutenant J. G. Harris's company (G), 25 men, was to occupy the north-east angle. Captain J. M. Mulvaney, Company C, 43 men, was to support Captain Miles. In case their services should not be needed, the last four companies were to remain formed on the parade below their respective positions, so as to be ready to move to any weak point.

I had procured from Charleston a supply of hand-grenades and fire-

balls. Detachments of men for each of these kinds of service were kept constantly in position at three different points of the parapet.

I requested Captain Champneys, the engineer in charge, to plant two *fougasses* in the wharf leading from the gorge. During the attack he kindly superintended their delivery.

At 1 A. M. (September 9), while observing a monitor which had taken a position near the fort, I saw the enemy pulling up from the eastward in two columns, the head of the one directed upon the north-east, that of the other upon the south-east, angle of the fort. I ordered up three companies within supporting distance, and reserved our fire until they had deployed and commenced to land. The outer boats replied rapidly for a few minutes.

The crews of those that had effected a landing sought refuge from the galling fire under the projecting masses of the wall, whence grenades and fire-balls soon dislodged them.

The fire of the Chicora, lying at a short distance to the northward, of Sullivan's Island to the north-east, and of Fort Johnson to the westward, encircled the work and effectually assisted to prevent any reinforcements coming up.

The enemy—with some of his boats disabled by hand-grenades and masses of masonry (convenient weapons to the ready hands of our garrison), and overwhelmed by our own and the fire of our supports—called for quarter, and were ordered in detail to make their way to the gorge, whence they were transferred to a place of security.

Not one of our men was injured. The whole force engaged on our side consisted of 80 riflemen and 24 men detached for service of the grenades and fire-balls. The remainder of the garrison were ready for action and remained in position.

The force of the enemy exceeded, according to the statements of captured officers, 400 men.

His ascertained loss was 6 killed, 15 wounded, and 106 prisoners, of whom 11 were officers.

We captured also five barges, five stand of colors (among them a flag said by the prisoners to be the flag borne from the fort by Major Robert Anderson in 1861), and a small quantity of arms and accoutrements. Most of the latter were thrown overboard by the prisoners and lost. Several boats drifted off with dead and wounded men.

The action was brief and decisive, as they found us prepared, and were themselves surprised at meeting more than a nominal resistance.

The Charleston battalion fully sustained its well-earned reputation by cheerfully enduring the hardships of its position and moving forward with energy in the moment of danger.

All the officers performed their duties well. The adjutant of the battalion, Lieutenant W. Mason Smith, rendered me throughout great assistance.

I have the honor to refer you to the accompanying papers, containing lists of killed, wounded, and prisoners, and of captured arms and other property, and also a sketch of the fort, showing the positions of the interior communications and the dispositions of the troops.

I cannot omit to mention the services of Captain J. T. Champneys, of the Engineer corps, who has shown great zeal and ability in conducting the defenses of this work.

Very respectfully, your obedient servant,

STEPHEN ELLIOTT, JR.,

*Major Artillery, Provisional Army C. S., commanding.*

Captain W. F. NANCE,

*Assistant Adjutant-General.*

*Congratulations from Richmond.*

WAR DEPARTMENT, C. S., }  
RICHMOND, September 9, 1863. }

GENERAL G. T. BEAUREGARD,

*Charleston, S. C.:*

Your telegrams, informing of the repulse of the iron-clads and of the late brilliant affair at Sumter, have been received with the liveliest satisfaction. We watch with intense anxiety the progress of your noble struggle, and each achievement illustrative of the constancy and heroism of your gallant brethren in arms is warmly appreciated, and affords hopeful augury of future triumph. The brave defenders of Charleston are honored and relied on throughout the Confederacy.

J. A. SEDDON,

*Secretary of War.*

*Intended Assault on Sumter by General Gillmore.*

*Special Orders* }  
*No. 150.* }

HEAD-QUARTERS U. S. FORCES, }  
MORRIS ISLAND, S. C., September 9, 1863. }

An attempt will be made to-night to carry Fort Sumter by assault. The regiments detailed for this purpose are the Tenth Connecticut and Twenty-fourth Massachusetts volunteers. Colonel Osborn, of the Twenty-fourth Massachusetts, will command the party. He will be accompanied by Major O. S. Sanford, Seventh Connecticut volunteers, on the staff of the brigadier-general commanding the post, who, having carefully reconnoitred the route to be taken, will be able to advise Colonel Osborn of it.

One hundred additional men for oarsmen have been detailed from the Seventh Connecticut and One-Hundred-and-Fourth Pennsylvania volunteers. The men will be embarked at the bridge immediately after sunset,



and the assault will be made at the earliest moment possible. Should the assault succeed, a red countersign light will be immediately burned from the parapet of the work.

After the capture of the fort the force will return at once, leaving 100 men as a garrison. These men must shelter themselves as far as possible in the uninjured casemates, and they will be supplied with provisions to-morrow night. A signal officer will accompany the party, who will remain with the garrison to be left in the fort.

The plan of the attack has been communicated verbally to Colonel Osborn. A red light burned on the fort prior to the arrival of Colonel Osborn's party will indicate that a similar attack has been successfully made by the navy.

On withdrawing the force the boats will be brought into Vincent's Creek, on the left of the approaches to Wagner. Every man will have the countersign "Detroit," and will use it as a watchword in making the assault.

By order of Brigadier-General A. H. TERRY.

ADRIAN TERRY,  
*Captain, and Assistant Adjutant-General.*

---

## CHAPTER IX.

[From *Battles and Leaders of the Civil War*, Century Co.]

### *The Opposing Land Forces at Charleston, S. C.*

The composition, losses, and strength of each army as here stated give the gist of all the data obtainable in the official records. (k stands for killed; w for wounded; m w for mortally wounded; m for captured or missing; c for captured.)

*Union*: Maj.-Gen. Quincy A. Gillmore, commanding Department of the South.

*Confederate*: General G. T. Beauregard, commanding Department of South Carolina, Georgia, and Florida.

### BATTERY WAGNER, JULY 18TH.

UNION.—FIRST DIVISION, Brig.-Gen. Truman Seymour (w).

First Brigade—Brig.-Gen. George C. Strong (m w): 6th Conn., Col. John L. Chatfield (m w), Capt. John N. Tracy; 9th Me., Col. Sabine Emery (w); 54th Mass. (colored), Col. Robert G. Shaw (k), Capt. Luis F. Emilio; 3d N. H., Col. John H. Jackson (w); 48th N. Y., Col. William B. Barton (w); 76th Pa., Captain John S. Littell. Second Brigade—Col. Haldimand S. Putnam (k): 7th N. H., Lieut.-Col. Joseph C. Abbott; 100th N. Y., Col. George B. Dandy; 62d Ohio, Col. Francis B.

Pond; 67th Ohio, Col. Alvin C. Voris (w). Artillery—Lieut.-Col. Richard W. Jackson and Capt. Loomis L. Langdon (in charge of siege-batteries): C, 3d R. I.; Capt. Charles R. Brayton; E, 3d U. S., Lieut. John R. Myrick.

Total Union loss: killed, 246; wounded, 880; captured or missing, 389 = 1515. The strength of the assaulting column (exclusive of Stevenson's brigade, held in reserve) is estimated at 5000.

CONFEDERATE.—Garrison—Brig.-Gen. William B. Taliaferro: 33d Ga., Col. George P. Harrison, Jr.; 31st N. C., Lieut.-Col. C. W. Knight; 51st N. C., Col. Hector McKethan; Charleston (S. C.) battalion, Lieut.-Col. P. C. Gaillard (w); 7th S. C. battalion, Maj. J. H. Rion. Artillery—Lieut.-Col. J. C. Simkins (k): 63d Ga. (2 co's.), Capts. J. T. Buckner and W. J. Dixon; 1st S. C. (2 co's.), Capts. W. T. Tatom (k) and Warren Adams; S. C. Battery, Capt. W. L. DePass.

Total Confederate loss: killed and wounded, 174.

Total force guarding fortifications around Charleston, about 8500.

Total engaged at Battery Wagner, about 1000.

#### SIEGE OPERATIONS, AUGUST-SEPTEMBER, 1863.

UNION.—MORRIS ISLAND, Brig.-Gen. Alfred H. Terry.

First Brigade—Col. Henry R. Guss: 9th Me., Lieut.-Col. Z. H. Robinson; 3d N. H., Capt. James F. Randlett; 4th N. H., Lieut.-Col. Louis Bell; 97th Pa., Maj. Galusha Pennypacker. Second Brigade—Col. Joshua B. Howell: 39th Ill., Col. Thomas O. Osborn; 62d Ohio, Col. F. B. Pond; 67th Ohio, Maj. Lewis Butler; 85th Pa., Maj. Edward Campbell. Third Brigade—Brig.-Gen. Thomas G. Stevenson: 7th Conn., Col. Joseph R. Hawley; 10th Conn., Maj. Edwin S. Greeley; 24th Mass., Col. Francis A. Osborn; 7th N. H., Lieut.-Col. J. C. Abbott; 100th N. Y., Col. G. B. Dandy. Fourth Brigade—Col. James Montgomery: 54th Mass. (colored), Col. M. S. Littlefield; 2d S. C. (colored), Lieut.-Col. W. W. Marple; 3d U. S. C. T., Col. B. C. Tilghman. Fifth Brigade—Col. W. W. H. Davis: 47th N. Y., Maj. C. R. McDonald; Independent Battalion N. Y., Capt. M. Schmitt; 52d Pa., Lieut.-Col. H. M. Hoyt; 104th Pa., Maj. E. L. Rodgers. Artillery—Lieut.-Col. R. W. Jackson and Capt. L. L. Langdon: B, 3d R. I., Capt. Albert E. Green; C, 3d R. I., Capt. Charles R. Brayton; D, 3d R. I., Capt. Richard G. Shaw; H, 3d R. I., Capt. Augustus W. Colwell; I, 3d R. I., Capt. Charles G. Strahan; M, 3d R. I., Capt. Joseph J. Comstock, Jr.; B, 1st U. S., Lieut. Guy V. Henry; C, 1st U. S. (detachment), Lieut. James E. Wilson; E, 3d U. S., Lieut. John R. Myrick; B, 3d N. Y., Capt. James E. Asheroft; F, 3d N. Y., Lieut. Paul Birchmeyer. Miscellaneous—Detachment 11th Me., Lieut. Charles Sellmer; Detachment I, 1st Mass. Cav., Lieut. Charles V. Holt; 1st N. Y. Engineers, Col. Edward W. Serrell.

## NORTH END OF FOLLY ISLAND, Brig.-Gen. Israel Vogdes.

African Brigade—Brig.-Gen. Edward A. Wild: 55th Mass., Col. Norwood P. Hallowell; 1st N. C., Col. James C. Beecher; 2d N. C. (detachment), Col. Alonzo G. Draper; 3d N. C. (detachment), Capt. John Wilder. Foster's Brigade—Brig.-Gen. R. S. Foster: 13th Ind., Col. Cyrus J. Dobbs; 112th N. Y., Col. Jeremiah C. Drake; 169th N. Y., Col. Clarence Buell, Alford's Brigade—Col. Samuel M. Alford: 3d N. Y., Lieut.-Col. E. G. Floyd; 89th N. Y., Col. Harrison S. Fairchild; 103d N. Y., Col. William Heine; 117th N. Y., Col. Alvin White. Artillery—1st Conn., Capt. A. P. Rockwell.

## SOUTH END OF FOLLY ISLAND, Brig.-Gen. Geo. H. Gordon.

First Brigade—Brig.-Gen. A. Schimmelfennig: 41st N. Y., Lieut.-Col. Detleo von Einsiedel; 54th N. Y., Capt. Clemens Knipschild; 127th N. Y., Lieut.-Col. Stewart L. Woodford; 142d N. Y., Col. N. Martin Curtis; 107th Ohio, Capt. William Smith; 74th Pa., Capt. Henry Krauseneck. Second Brigade—Brig.-Gen. Adelbert Ames: 17th Conn., Col. W. H. Noble; 40th Mass., Lieut.-Col. Joseph A. Dalton; 144th N. Y., Col. David E. Gregory; 157th N. Y., Maj. James C. Carmichael; 25th Ohio, Capt. Nathaniel Haughton; 75th Ohio, Col. A. L. Harris.

Recapitulation of Union losses, July 10th–Sept. 7th:

	Killed.	Wounded.	Captured or Missing.	Total.
Morris Island, July 10th . . . . .	15	91	. . .	106
Battery Wagner, July 11th . . . . .	49	123	167	339
Battery Wagner, July 18th . . . . .	246	880	389	1515
Siege operations, July 18th–Sept. 7th . . . . .	71	278	9	358
Total on Morris Island . . . . .	381	1372	565	2318

The effective strength of the land forces employed in the direct operations against Charleston ranged from 11,000 to 16,000.

The loss from Sept. 8 to Dec. 31, 1863, was 14 killed and 42 wounded = 56.

CONFEDERATE—FIRST MILITARY DISTRICT,<sup>1</sup> Brig.-Gen. R. S. Ripley.

First Subdivision—Brig.-Gen. William B. Taliaferro: 6th Ga., Col. John T. Lofton; 19th Ga., Col. A. J. Hutchins; 32d Ga., Col. George P. Harrison, Jr.; 54th Ga., Col. C. H. Way; 31st N. C., Col. John V. Jordan; 21st S. C., Col. R. F. Graham; 25th S. C., Col. C. H. Simonton;

<sup>1</sup> The troops and commanders employed in the defense of Morris Island were relieved from time to time. The commanders were Brig.-Gen. W. B. Taliaferro, Brig.-Gen. Johnson Hagood, Brig.-Gen. A. H. Colquitt, Col. R. F. Graham, Col. George P. Harrison, Jr., and Col. L. M. Keitt.

Marion (S. C.) Art'y, Capt. E. L. Parker; Chatham (Ga.) Art'y, Capt. John F. Wheaton; Palmetto (S. C.) battalion Art'y, Lieut.-Col. E. B. White; S. C. Battery, Capt. J. T. Kanapaux; A, 1st S. C. Art'y, Capt. F. D. Blake; Ga. and S. C. Siege Train, Maj. Edward Manigault; 2d S. C. Art'y, Col. A. D. Frederick; S. C. Art'y, Capt. John R. Mathewes; Gist Guard (S. C.) Art'y, Capt. C. E. Chichester; 5th S. C. Cav. (4 co's.), Col. John Dunovant; Lucas's (S. C.) battalion, Maj. J. J. Lucas; 23d Ga., Maj. M. R. Ballenger; 27th Ga., Maj. James Gardner; 28th Ga., Capt. W. P. Crawford; 1st, 12th, and 18th Ga. battalions, Col. C. H. Olmstead; C, F, and I, 1st S. C. Art'y, Lieut.-Col. J. A. Yates; Savannah River Batteries, Capt. W. W. Billop; 11th S. C., Col. F. H. Gantt. Second Subdivision—Brig.-Gen. Thomas L. Clingman: 7th S. C. battalion, Lieut.-Col. P. H. Nelson; 8th N. C., Col. H. M. Shaw; 51st N. C., Col. H. McKethan; 61st N. C., Col. J. D. Radcliffe; 20th S. C., Col. L. M. Keitt; German Art'y, Capt. F. W. Wagener; Inglis (S. C.) Art'y, Capt. W. E. Charles; 1st S. C., Col. William Butler; S. C. Cav., Capt. A. D. Sparks; E, 5th S. C. Cav., Capt. L. A. Whilden; H and K, 1st S. C. Art'y, Capt. H. R. Lesesne and A. S. Gaillard. Third Subdivision (Morris Island)—Brig.-Gen. A. H. Colquitt: [The troops of this command were drawn from other subdivisions and appear in the commands to which they properly belonged.] Fourth Subdivision (Fort Sumter)—Col. Alfred Rhett, Maj. Stephen Elliott, Jr.: B, D, and E, 1st S. C. Art'y; B, 27th Ga.; F, 28th Ga. Castle Pinckney and Fort Ripley: G, 1st S. C. Art'y, Capt. W. H. Peronneau. [Subsequent to the fall of Morris Island other troops were detailed, in turn, to garrison Fort Sumter.] Fifth Subdivision—Brig.-Gen. W. G. DeSaussure: 1st S. C. (Mil.), Col. Ed. Magrath; 1st S. C. Art'y (Mil.), Col. J. A. Wagener; 18th S. C. (Mil.), Col. J. E. Carew; battalion State Cadets, Maj. J. B. White; D and H, 5th S. C. Cav., Lieut.-Col. R. J. Jeffords; K, 4th S. C. Cav., Capt. R. H. Colcock; S. C. Battery, Capt. W. E. Earle; Charleston battalion, Maj. Julius A. Blake. Evans's Brigade<sup>1</sup>—Brig.-Gen. N. G. Evans: 17th S. C., Col. F. W. McMaster; 18th S. C., Col. W. H. Wallace; 22d S. C., Col. S. D. Goodlett; 23d S. C., Col. H. L. Benbow; 26th S. C., Col. A. D. Smith; Holcombe Legion, Lieut.-Col. W. J. Crawley. Anderson's Brigade<sup>1</sup>—Brig.-Gen. G. T. Anderson: 7th Ga., Col. W. W. White; 8th Ga., Col. John R. Towers; 9th Ga., Col. B. Beck; 11th Ga., Col. F. H. Little; 59th Ga., Col. Jack Brown. Wise's Brigade<sup>1</sup>—Brig.-Gen. Henry A. Wise: 26th Va., Col. P. R. Page; 4th Va. Heavy Art'y, Col. J. T. Goode; 46th Va., Col. R. T. W. Duke; 59th Va., Col. W. B. Tabb.

General Beauregard, in his official report, says: "The total loss in killed and wounded on Morris Island from July 10th to September 7th was only 641 men; and deducting the killed and wounded due to the landing on July 11th and 18th, the killed and wounded by the terrible

<sup>1</sup> Joined after capture of Morris Island by Union forces.

bombardment, which lasted almost uninterruptedly, night and day, during fifty-eight days, only amounted to 296 men, many of whom were only slightly wounded. It is still more remarkable that during the same period of time, when the enemy fired 6202 shots and shells at Fort Sumter, varying in weight from 30 to 300 pounds, only 3 men were killed and 49 wounded."

The entire loss in the defenses of Charleston from July 10th to September 7th was 157 killed, 674 wounded, and 159 captured or missing = 990. (See *Official Records*, vol. xxviii., part i. p. 409.)

It is estimated that the force defending the immediate approaches to Charleston ranged from 6500 to 18,000.

*Remarks Relative to Iron-clad Gunboats.*

CHARLESTON, S. C., }  
Nov. 14, 1863. }

Our gunboats are defective in six respects:

First. They have no speed, going only from three to five miles an hour in smooth water and no current.

Second. They are of too great draught to navigate our inland waters.

Third. They are unseaworthy by their shape and construction, as represented by naval officers. Even in the harbor they are at times considered unsafe in a storm.

Fourth. They are incapable of resisting the enemy's XV-inch shots at close quarters, as shown by the Atlanta in Warsaw Sound last spring.

Fifth. They cannot fight at long range, their guns not admitting an elevation greater than from 5° to 7°, corresponding to 1½ to 1¼ miles range. Even at long range, naval officers are of opinion that the oblique sides and flat decks of our gunboats would not resist the plunging shots of the enemy's 200- and 300-pounders.

(The best proof of total failure of the three iron-clad gunboats, Chicora, Palmetto State, and Charleston, constructed at such cost and labor, is that, although commanded by our most gallant officers, they did not fire one shot in the defense of Fort Sumter during the naval attack of the 7th of April last, nor have they fired a shot in the defense of Morris Island and Sumter during the present siege, which has lasted over four months, excepting on one occasion, the assault on Sumter during the night of September 8th last, when the Chicora fired a few shots on the enemy's boats and barges.)

Sixth. They are very costly, warm, uncomfortable, and badly ventilated, consequently sickly.

The enemy's iron-clads being invulnerable to shots above water beyond 800 yards, they should be attacked below water. The best way to accomplish this is by means of swift sea-going steamers, capable of travelling ten or twelve miles an hour, shot-proof above water and armed

with Captain F. D. Lee's submarine repeating spar-torpedo, which is both simple and certain in its operation. Not one of his submarine torpedoes has yet failed to explode on striking a resisting object. The experiment of the *David*, a small cigar torpedo-boat, against the *New Ironsides* shows the effect of a 70-pound torpedo, only six feet below water, on the thick sides—over five feet—of that sea-monster. Since the attack, about one month ago, the *New Ironsides* has not fired one shot, notwithstanding the renewed bombardment of Sumter has been going on twenty days and nights, showing evidently that she has been seriously injured. Moreover, she has left her anchorage only once for about half an hour, when she returned to her former position, abreast of Morris Island. It is stated that a proper-sized steamer, 400 or 500 tons, built like a blockade-runner, but made shot-proof and armed with one of Lee's repeating submarine torpedo apparatus, could be built in about three months' working-time in England for the sum of about \$250,000.

I venture to say that with one of those vessels here the blockade of Charleston could be raised in less than one week, and the army of Gillmore captured very shortly afterward. Half a dozen of these steamers would raise the blockade of our Atlantic and Gulf coasts, and enable us to recover the navigation of the Mississippi River. Indeed, a few years hence we will ask ourselves in astonishment how it was that with such a great discovery, offering such magnificent results, we never applied it to any useful purpose in this contest for our homes and independence. It is evident, according to Lord John Russell's own views, that those steamers can be constructed in England as shot-proof, unarmed blockade-runners without incurring the risk of being seized by the English Government.

G. T. BEAUREGARD,  
*General C. S. Army.*

FORT SUMTER, September 21, 1863.

Captain W. F. NANCE, A. A.-G.—

CAPTAIN: I have the honor to report that I consider this work still capable of offensive operations. The arches of four of the lower casemates on the north-eastern face are uninjured, are partially defiladed by the south-eastern face, and to a great extent protected above and in the rear by masses of the upper arches. This face can be injured only by a fire from the direction of Sullivan's Island, provided sufficient protection can be afforded from the reverse-fire of the batteries on Morris Island. I recommend that the subject receive immediate attention.

Very respectfully, your obedient servant,

STEPHEN ELLIOTT, JR.,  
*Major Artillery, commanding post.*

[This suggestion was immediately considered and accepted. The commanding general ordered the chief engineer, Lieutenant-Colonel Harris, to fortify, arm, and protect the available casemates, under date of September 25, 1863.]

*The Monitor Lehigh aground.—Action with Fort Moultrie.*

HEAD-QUARTERS, FORT MOULTRIE, November 17, 1863.

LIEUTENANT: I have the honor to report that on the morning of the 16th, about 7.15 o'clock, a monitor was discovered to be aground opposite this post. Fire was immediately opened upon her with effect, many shots having been seen to strike. She made no reply, but began to signalize the fleet; when three other monitors came to her assistance, and, taking position about 1800 or 2000 yards distant, opened fire from rifled and XV-inch guns, using shot, shell, and grape. The greater portion of our fire was directed at the monitor aground, but, owing to her greater distance, we were enabled to bestow some attention to each of the others. 189 shots were fired, to which the enemy replied with 73—52 from their monitors and 21 from their land-batteries on Morris Island. Five additional shots from land-battery were fired at this fort at 5.30 P. M.

The guns at this post were manned by three companies of First South Carolina [regular] Infantry: Company C, Captain B. J. Witherspoon commanding, assisted by Lieutenant Vincent F. Martin; Company F, Lieutenant E. M. Whaley commanding; and Company G, Lieutenant J. C. Minott commanding. The guns in the battery manned by Company F could not be brought to bear, and consequently were not engaged. The conduct of both officers and men under the fire was highly creditable to themselves and satisfactory to me. But for the dismounting of a 32-pounder rifled gun by the bursting of a XV-inch shell, and the wounding of 4 men by the explosion of another in the sally-port, this post would have escaped without casualty of any kind, although repeatedly struck.

I have the honor to add a list of wounded: Private Amos Helmes, Company C, lacerated wound of thigh and face, since died; Sergeant T. Hamilton, Company G, contusion of face, slight; Private J. L. Dawson, Company G, lacerated wound of face and arm, severe; Private Thomas Scott, Company E, lacerated wound of face, severe.

Respectfully, your obedient servant,

J. VALENTINE,

*Captain, commanding Post.*

Lieutenant E. C. EDGERTON, A. A. A.-G.

[From the report of her commander, A. Bryson, it appears that the Lehigh was struck twenty-two times, nine of these being serious injuries of the deck-plating. 1 officer and 6 men were also wounded.]

*Particulars of the Sinking of the Weehawken at her Anchorage off  
Morris Island, December 6, 1863.*

About 2 P. M., a moderate gale blowing from the north-east, this vessel, after laboring for an hour or more at her anchorage, suddenly went down by the head, sinking in five minutes to the bottom, and showing about two feet of her smokestack above water: 11 officers and 50 men were saved; 4 officers and 26 men were lost. The court of inquiry found the first cause of the accident was: "The additional weight of the ammunition that had been lately put on board of her, leaving her trim so little by the stern as not to allow sufficient inclination for water to get to her pumps freely." It was also held by some that "the injuries the vessel had received in service, particularly while aground under the fire of the Sullivan's Island batteries, assisted perhaps by the straining produced by being beached at Port Royal," had something to do with the disaster.—J. J.

CHAPTER X.

*Report of Lieutenant-Colonel Elliott, commanding Fort Sumter, concerning the Explosion of Magazine and Fire.*

*December 12th.*—At 9.30 yesterday morning the south-west magazine exploded. Owing to the want of space, the ammunition for small-arms and howitzers, amounting to about 150 pounds of powder, was stored in the inner room. The commissary stores were kept principally in the outer room, which was also used as an issuing office. The materials in these rooms were immediately ignited, their occupants killed, and those stationed in the adjoining passages either killed or burned with greater or less severity.

The passages leading to the lower and upper tiers of casemates, and those casemates themselves, were filled instantly with the most dense smoke, introduced by a blast of great strength, whose flame was visible from the room occupied as head-quarters. In total darkness the occupants rushed from the stifling smoke to the open embrasures, leaving their arms and blankets behind. The continuance of the smoke prevented any prolonged attempt to obstruct the progress of the fire.

With great promptness a boat was sent from the navy with a supply of water-buckets. The telegraphic apparatus was removed and located at another position by Mr. W. R. Cathcart, the operator, who behaved remarkably well; but he was compelled to retire from this second position by the advance of the fire.

The signal officers made repeated efforts to attract the attention of Sullivan's Island and Fort Johnson, but were unable to succeed until a



late hour in the day. The Sullivan's Island corps could be seen operating with other points—an inattention, when it was known that we were under unusual circumstances and cut off from all communication, which seems to me reprehensible in the extreme, and ought, I think, to be looked into.

The effect of the fire was to destroy the roof of the magazine and the south-west stairway, the woodwork in the two tiers of casemates, as far in the lower as the old sally-port.

The damage done will not materially affect the defense of the work. Captain J. Johnson of the Engineers was everywhere, doing everything that man could do.

Lieutenant L. A. Harper, Company F, Twenty-fifth South Carolina volunteers, showed great gallantry in rescuing burning bodies from the smoke and flames. Captain M. H. Sellers, of the same company, gave me great assistance in superintending the arrangement last night, at a time when a slight temporary injury prevented me from running about.

Soon after the fire became apparent the enemy opened fire, throwing 143 rifle-shots, of which 18 missed, and 77 mortar shells, of which 15 missed.

The deficiencies in men, arms, and commissary stores were most promptly supplied by the authorities.

The following is a list of the casualties :

Killed: Captain Edward D. Frost, assistant commissary of subsistence; Sergeant Hannon, White's battalion Artillery; Sergeant John King, Company E, Twenty-fifth South Carolina volunteers; Thomas McElroy, Company E, Twenty-fifth South Carolina volunteers; B. Douglas, Company F, Twenty-fifth South Carolina volunteers; Sergeant Robert Swanston, Company K, First South Carolina Artillery; P. Sill, Company K, First South Carolina Artillery; A. Surten, Company K, First South Carolina Artillery; W. J. Lee, Company I, Nineteenth Georgia; B. Jones, Company H, Nineteenth Georgia; J. T. Ford, Company G, Twenty-seventh Georgia.

Wounded: Lieutenant-Colonel Elliott, slight, in head and ankle; Captain N. B. Mazyck, Company E, Twenty-fifth South Carolina volunteers; C. F. Vogler, Company E, Twenty-fifth South Carolina volunteers; J. Brennan, Company E, Twenty-fifth South Carolina volunteers; Sergeant J. E. Prince, Company E, Twenty-fifth South Carolina volunteers; R. Flotwell, Company E, Twenty-fifth South Carolina volunteers; T. Callahan, Company E, Twenty-fifth South Carolina volunteers; H. Hutson, Company E; D. H. Clayton, Company E; C. Fertig, Company F; D. Avinger, Company F, Twenty-fifth South Carolina volunteers.

Privates Edward Spigner, Company F, Twenty-fifth South Carolina volunteers; N. W. Shuler, Company F, Twenty-fifth South Carolina volunteers; P. H. Taylor, Company F, Twenty-fifth South Carolina

volunteers; R. D. Zimmerman, Company F, Twenty-fifth South Carolina volunteers; W. C. Zimmerman, Company F, Twenty-fifth South Carolina volunteers; H. Shirer, Company F, Twenty-fifth South Carolina volunteers; B. Buhn, Company B, Nineteenth Georgia volunteers; N. C. Jones, Company H, Nineteenth Georgia volunteers; Elisha Harris, Company E, Sixth Georgia volunteers; J. B. Buckman, Company G, Sixth Georgia volunteers; B. F. Brooks, Company G, Sixth Georgia volunteers; J. M. Huddleston, Company E, Nineteenth Georgia volunteers; W. Dunning, Company H, Twenty-seventh Georgia volunteers; N. F. Smith, Company C, Nineteenth Georgia volunteers; J. Hemphill, Company D, Twenty-seventh Georgia volunteers; A. W. Wells, Company E, Sixth Georgia volunteers; J. Hodge, Company A, Twenty-seventh Georgia volunteers; J. S. Price, Company C, Sixth Georgia volunteers; W. B. Chandler, Company K, Sixth Georgia volunteers; W. B. Leatherwood, Company I, Nineteenth Georgia volunteers; H. C. Adair, Company H, Nineteenth Georgia volunteers; J. M. Carney, Company A, Sixth Georgia volunteers; Sergeant James Reed, Company K, Nineteenth Georgia volunteers; Private W. F. Danan, Company A, Twenty-seventh Georgia volunteers; Sergeant J. C. Calhoun, Company A, Twenty-seventh Georgia volunteers; Privates L. Mashburn, Company K, First South Carolina Artillery; J. Leech, Company K, First South Carolina Artillery; L. W. Dantzer, Company F, Twenty-fifth South Carolina volunteers; Percival Elliott, Signal Corps; B. F. Watson, Company D, Sixth Georgia volunteers.

*Recapitulation.*

Killed . . . . .	11
Wounded . . . . .	41
Total . . . . .	52

*Report of the Sinking of the Sloop-of-war Housatonic by a Torpedo-Bot.*

UNITED STATES STEAMER CANANDAIGUA, }  
OFF CHARLESTON, S. C., Feb. 18, 1864. }

SIR: I have the honor to make the following report of the sinking of the United States steamer Housatonic by a rebel torpedo off Charleston, S. C., on the evening of 17th inst. :

About 8.45 P. M. the officer of the deck, Acting Master J. K. Crosby, discovered something in the water about one hundred yards from, and moving toward, the ship. It had the appearance of a plank moving in the water. It came directly toward the ship, the time from when it was first seen till it was close alongside being about two minutes. During this time the chain was slipped, engine backed, and all hands called to quarters. The torpedo struck the ship forward of the mizzen-

mast on the starboard side, in a line with the magazine. Having the after pivot-guns pivoted to port, we were unable to bring a gun to bear upon her. About one minute after she was close alongside the explosion took place, the ship sinking stern first, and heeling to port as she sank. Most of the crew saved themselves by going into the rigging, while a boat was despatched to the Canandaigua. This vessel came gallantly to our assistance, and succeeded in rescuing all but the following officers and men—viz.:

Ensign E. C. Hazeltine, Captain's Clerk C. O. Muzzey, Quartermaster John Williams, Landsman Thomas Parker, Second-class Fireman John Walsh. The above are missing, and are supposed to have been drowned.

Captain Pickering was seriously bruised by the explosion, and is at present unable to make a report of the disaster.

Very respectfully, your obedient servant,

F. J. HIGGINSON,

Rear-Admiral JOHN A. DAHLGREN,

Lieutenant.

Commanding *S. A. B. Squadron.*

*Confederate Attack on Gunboat Marblehead in Stono River.—Report of Brigadier-General Henry A. Wise, C. S. Army, commanding Sixth Military District.*

HD-QRS. 6TH MIL. DIST., DEPT. OF S. C., GA., AND FLA., }  
December 25, 1863, 6.15 P. M. }

GENERAL: Every preparation was duly made against Legaréville and the gunboats. The batteries were completed and everything ready and in position by daylight, and our fire opened at the appointed time upon the Marblehead, about 300 yards from the wharf of the village landing. The enemy's force on land was about 200—not in the village, but on a little island with a narrow defile leading to it. Colonel Page determined to attack with a field-battery and the infantry, but to do so waited for our siege-guns to drive the gunboat from the wharf. She didn't open for twenty minutes after our fire commenced. Our fire was kept up for about an hour at 1000 yards' distance without making the least impression, or, as Colonel Page thinks, even hitting her at all. (See Union report.)

In the mean time, the Pawnee and a mortar-boat ran up the Kiawah and opened fire on flank and rear of our lower batteries, killing 1 private, severely wounding 5 others (2 supposed mortally), and killing 8 horses. Colonel Page instantly withdrew and fell back, the infantry to Roper's and the artillery to Walpole's.

On hearing the heavy firing this morning, I hastened in person to the ground, and met Colonel Page at the latter place. Learning the above from him, and that two howitzers (heavy) and the body of the one private

REPORTS, CORRESPONDENCE, DESPATCHES, ETC. cli

were left on the ground, I approved of Colonel Page's resolve before I reached him to remain until to-morrow, and I ordered him to regain, if possible, to-night the guns and the dead. He has rations and forage until Sunday next, the 27th. His official report will be made as soon as the expedition is ended. I regret its failure.

I am, general, your obedient servant,

HENRY A. WISE,

*Brigadier-General, commanding.*

General G. T. BEAUREGARD, *commanding, etc.*

*Report of Colonel P. R. Page, Twenty-sixth Virginia Infantry.*

WALPOLE'S, December 25, 1863.

CAPTAIN: I am sorry to say to the general that the expedition has been a failure. We opened the attack at daylight this morning, according to instructions, the Marblehead alone being in Stono. The vessel was never touched by the artillery (?). The Pawnee and a mortar-boat soon came up the Kiawah, flanking our lower batteries, and we were compelled to withdraw, with the following casualties in the artillery, as reported by Colonel Del Kemper: 1 man killed and 5 severely wounded, and Captain B. C. Webb slightly; 8 artillery-horses killed and 1 ambulance-mule from the Twenty-sixth regiment. There were no casualties in the infantry.

Very respectfully, your obedient servant,

P. R. PAGE,

*Colonel, commanding.*

Captain J. H. PEARCE,  
*Assistant Adjutant-General.*

*Extracts from Report of Lieutenant-Commander R. W. Meade, U. S. Gunboat Marblehead.*

"The enemy on John's Island opened fire on us at six o'clock this morning from two batteries of field and siege artillery, posted advantageously in the woods. . . . We replied vigorously to the enemy, and slipping the cable, took a position nearer their guns; on which, after a sharp contest of an hour, the enemy retired in disorder, leaving guns and caissons behind them. . . . The enemy's fire was very effective, and the vessel is badly cut up aloft (losing maintopmast; . . . her foremast is wounded). She has twelve shots in the hull (one between wind and water); eighteen shots struck in the upper works and aloft. . . . The vessel has lost 3 men killed and 4 wounded. . . . The Pawnee, which when the action commenced was at anchor in the inlet, took an enfilading position on the Kiawah River, and by her fire contributed greatly in demoralizing the enemy and forcing him to retreat. The mortar-schooner C. P. Williams also came up and joined in the action."

*Commander George B. Balch, of the Pawnee, says: "The enemy's fire did not cease or diminish until the Pawnee and the C. P. Williams got into position; and to the combined effort of the three vessels engaged an undoubted claim may be laid as highly creditable to the navy."*

---

## CHAPTER XI.

*Opinion of Commodore John Rodgers upon the Defenses of Charleston Harbor, given before a Committee of the United States Senate, February 3, 1864.*

"Ordinarily and popularly, to take a place means to take its defenses. General Gillmore was forty-eight days on Morris Island, acting against Fort Wagner, with some 10,000 or 12,000 men against a garrison of about 1500, more or less, assisted by the monitors and by artillery which excited the wonder of Europe. After forty (fifty)-eight days he took the place, not by his artillery nor by his monitors, but by making military approaches and threatening to cut off their means of escape and take the place by assault; and when he took it, it was not so greatly damaged as to be untenable. Now, if General Gillmore, on the same island, assisted by his artillery and the whole force of monitors, in forty (fifty)-eight days, could not capture Fort Wagner alone by them, it is perfectly certain that the monitors alone can never take the much stronger defenses which line James Island and Sullivan's Island. In going up to Charleston, therefore, he would have to run by the defenses, and leave the harbor, so far as they constitute the command of it, in the power of the enemy; and when he got up to the city he could not spare a single man from his monitors, even if they should consent to receive him; and if he burned the town, he would burn it over the heads of non-combatant women and children while the men who defend it are away in the forts. I should be reluctant to burn a house over a woman's and child's head because her husband defied me. Dahlgren, if he burns Charleston, will be called a savage by all Europe, and after the heat of combat is over he will be called a savage by our own people. But there are obstructions in the way which render it doubtful whether he can get there. And if he goes up under the guns of those fortifications, sticks upon the obstructions, and is finally driven off by any cause, leaving one or two of his monitors there within their power, they will get them off, repair them, and send them out to what part of the coast they please, and give a new character to the war. The wooden blockade will be mainly at an end, unlimited cotton going out and unlimited supplies coming in. I see no good to compensate for that risk, except it be in satisfying the national mind that retributive justice has been done against the city of

Charleston, the nursery of the rebellion. . . . In a word, I do not think the game is worth the candle. Whether these reasons operate with him, I do not know; they would with me."

*Operations on James Island—Assault on Fort Johnson, July 3, 1864—Bombardment of Battery Pringle and the Lines, July 8th and 9th.*

HD-QRS. DEPT. SOUTH CAROLINA, GEORGIA, AND FLORIDA, }  
 CHARLESTON, July 4, 1864. }

TO GENERAL S. COOPER, *Adjutant- and Inspector-General:*

On the morning of the 2d instant the enemy landed several regiments on the south side of James Island, supported by two monitors and several gunboats in the Stono, and after a sharp skirmish captured two pieces of field artillery and commenced intrenching. At the same time several gunboats and transports with troops came up the North Edisto.

At early dawn yesterday from 700 to 1000 men in barges attacked Fort Johnson, and were handsomely and thoroughly repulsed, with the loss to the enemy of 140 prisoners with their arms and accoutrements, and five barges, and many killed and wounded. Our loss very slight.

The enemy on the south end of James Island fell back hastily yesterday before our men, leaving their dead unburied, and our picket-line is re-established; but the monitors and gunboats are still in the Stono, firing heavily on our lines, and another transport has just come up with troops. The party from North Edisto landed at White Point and advanced, but were met and driven back. So far, the enemy has been repulsed at all points, with a loss of about 600 men, but the position and movements of the enemy on James and John's Islands and adjacent river threaten most serious danger to this city. I am in extreme need of reinforcements—have not yet any of the South Carolina reserves. My men are greatly exhausted, and under the incessant fire of the monitors and gunboats two-thirds of them will soon be unfit for duty. Some assistance should be speedily sent me. Please lay this before the President.

SAM JONES,  
*Major-General.*

*Extract from the Report of Brigadier-General W. B. Taliaferro, commanding Seventh Military District of South Carolina.*

"On the morning of the 3d, at daylight, two columns of barges were observed rapidly approaching the Shell Point beach, upon which the several batteries known as 'Simkins' are situated, and which is immediately connected with the important post and harbor defense of Fort Johnson. One column landed its men near the end of this point, and

the other and larger between Battery Simkins' and Fort Johnson, which post was, simultaneously with Shell Point, fiercely assaulted. The gallant garrison, under the command of Lieutenant-Colonel J. A. Yates, received them with heroic determination, and the efficient and rapid discharges of heavy and light guns and the unerring fire of our musketry soon staggered and drove them back, when, with a rapid charge upon the enemy, headed by Lieutenants Thomas Davis Waties and James C. Reynolds of the artillery, 140 prisoners, including 5 commissioned officers, were taken before they could make good their escape.

"The participants in this brilliant affair were Company G, First South Carolina Artillery, Lieutenant Waties; Company K, Captain Alfred S. Gaillard; detachment Company E, Lieutenant R. L. Cooper, and detachments Companies A and E, Second South Carolina Artillery, Lieutenants M. P. Halsey and G. F. Raworth. These officers and Corporal Daniel D. Crawford, Company G, are spoken of in high terms of praise by Lieutenant-Colonel Yates for gallantry displayed on the occasion. Five barges fell into our hands, and it is certain that the enemy's loss in killed and wounded was heavy.

"At the Stono batteries (Pringle and Tynes, on the 8th and 9th July) the officers and men behaved with gallantry under fire and deserve especial mention. The officers are Major J. J. Lucas, commanding, and Major O. Blanding, First South Carolina Artillery; Captains Theo. B. Hayne and Guignard Richardson, Lucas's battalion; Lieutenants Julius M. Rhett, McMillan King, and H. M. Stuart, First South Carolina Artillery; and Lieutenants W. G. Ogier, W. D. Martin, W. W. Reverly, Thomas E. Lucas, and J. D. Ford of Lucas's battalion. Lieutenant Ogier is particularly mentioned for his gallantry.

"The batteries at Fort Lamar (Secessionville), under Lieutenant-Colonel J. Welsman Brown, and those on the southern lines, under Captain T. K. Legaré, did good service during the continuance of these operations, as did the light batteries under the command of Captain John F. Wheaton of the Chatham Artillery." . . .

WM. B. TALIAFERRO,  
*Brigadier-General, commanding.*

*General Orders* }  
*No. 153.* }

HEAD-QUARTERS DEPT. OF THE SOUTH, }  
HILTON HEAD, S. C., Nov. 7, 1864. }

The following summary of evidence relative to the attack on Forts Johnson and Simkins in July last is published for the information of the command. Its publication has been delayed by the illness and prolonged absence of Brigadier-General Schimmelfennig, who was originally charged with the investigation:

At 2 A. M. July 3, 1864, the Fifty-second Pennsylvania volunteer Infantry, Colonel H. M. Hoyt, and the One-Hundred-and-Twenty-

seventh New York volunteer Infantry, Major E. H. Little, with 60 men of the Third Rhode Island Artillery, left Paine's Dock, Morris Island, in boats and under orders to take Forts Johnson and Simkins. They were to cross Charleston harbor till opposite the beach between the forts, then move by the left flank, pull vigorously to land, and assault with the bayonet. Clear and precise instructions were given to all concerned. The only signal of retreat was to be sounded on a bugle in possession of Colonel Hoyt.

The pilot failed to find the passage through the bar near Fort Johnson, but a narrow channel was at last discovered near shore. Through this many of the boats had passed, when, day breaking, the enemy opened a heavy fire, which was, however, almost entirely harmless, passing far overhead.

The boats commanded by Colonel Hoyt, Lieutenant-Colonel Conyngnam, Captain Camp, and Lieutenants Stevens and Evans, all of the Fifty-second Pennsylvania, rowed rapidly to the shore, and these officers, with Adjutant Bunyan (afterward killed) and 135 men, landed and drove the enemy, but, deserted by their comrades, were obliged to surrender to superior numbers.

Colonel Hoyt bestows unqualified praise on the officers and men who landed with him; of them 7 were killed and 16 wounded. Colonel Hoyt himself deserves great credit for his energy in urging the boats forward and bringing them through the narrow channel; and the feeling which led him to land at the head of his men was the prompting of a gallant spirit which deserved to find more imitators.

At the time of Colonel Hoyt's landing great confusion existed in the second and third divisions of the Fifty-second Pennsylvania regiment, and a retreat commenced; it is impossible to discover which boats first led off the disgraceful movement, the occupants of each declaring that others were retreating before they themselves turned. These divisions falling back in confusion, the One-Hundred-and-Twenty-seventh shared the general movement, and the whole expedition returned to Paine's Dock.

Colonel William Gurney, One-Hundred-and-Twenty-seventh New York regiment, commanding Morris Island, who was charged with sending the expedition, did not accompany it, but remained at Paine's Dock. There seems no sufficient reason for this conduct. The presence of a commanding officer when the landing was effected would have been of the greatest service in preventing the retreat.

The chief cause of failure was the lack of spirit, energy, and power of command on the part of subordinate officers. In such an expedition the commanders of boats exercise, in a great measure, an independent authority, while at the same time they are able to hold the men completely under their control. It is on them the main responsibility must rest, and it is plain that many of them were totally unequal to the occa-



sion. . . . The One-Hundred-and-Twenty-seventh New York regiment showed more coolness and better discipline; still, they not only retreated without proper orders, but are gravely in fault for not obeying the peremptory orders of their commanding officer, Major Little (who seems to have done everything that could be done), to land at once. From this censure must be excepted Captain Henry and Lieutenants Little and Abercrombie, who brought their boats to shore and landed. Captain Weston, too, deserves favorable mention. The officers and men of the Third Rhode Island Artillery appear to have behaved well.

The expedition was well planned, and would have succeeded had it not been for the absence of the commanding officer and the want of spirit and energy on the part of many of his subordinates.

The major-general commanding regrets that he has felt it his duty to make known the results of investigation into an affair which reflects so little credit on most of those concerned. He has reason to hope that many are heartily ashamed of their conduct, and he trusts it will be a lesson to the whole command, and especially to officers of all grades, how indispensable to the success of the most promising plan is the possession of determination and soldierly spirit by those who are to execute it.

By command of Major-General J. G. FOSTER.

[Official.]

W. L. M. BURGER,

*Assistant Adjutant-General.*

*Operations on John's Island.—Extracts from Report of Major John Jenkins, Third South Carolina Cavalry.—Fight at Gervais's Field, John's Island, July 7, 1864.—Assault of Enemy's Lines by Georgia Brigade, July 9, 1864.*

"The enemy for the first time brought forward artillery, and a sharp engagement ensued between their and our artillery, the two guns of the Marion (Artillery), under Lieutenant Robert Murdoch, two howitzers of Charles's battery, under command of Lieutenant T. B. Logan, making excellent practice, all under the supervision of Captain E. L. Parker of the Marion Artillery.

"At 11 A. M. the firing had ceased, and everything being quiet, at 3 P. M. I left for Charleston to see Major-General Jones, who had been endeavoring unsuccessfully to communicate with me by signals.

"During my absence the enemy attacked and succeeded in turning our extreme right by a flank movement, but the cavalry, dismounted, under command of Captain T. H. Clark, Second South Carolina regiment, made a most determined and desperate resistance, his company of 21 men present losing 13—7 killed and 6 wounded. He was ably seconded

by Captain A. H. Dean of same regiment, who with thirteen men charged the enemy on their left flank, throwing them into confusion. A gun of the Marion Artillery, judiciously posted, rendered much assistance in repelling the enemy or holding him in check until our right was reinforced by companies from the First and Thirty-second Georgia regiments, drawn from a position of our line which was not engaged, and led to the assistance of Major Wayne, commanding in my absence, who displayed alike correct judgment and cool courage and skill in handling his troops, and handsomely repulsed the enemy with loss in repeated assaults upon our line. One of the Parrott guns of the Washington Artillery, Lieutenant S. G. Horsey commanding, was particularly effective, being advanced in front of our line and enfilading the assaulting-party of the enemy.

“ On the 8th, Brigadier-General Robertson arrived and took command. Reinforcements came up. He determined to attack the enemy and drive him from the island. At two o'clock on the morning of the 9th, I was ordered by General Robertson to direct Colonel George P. Harrison, Jr., of the Thirty-second Georgia, to advance upon the enemy and carry his lines unless he encountered too severe a fire of artillery, in which event he was to withdraw and not sacrifice his men. I was ordered by the general to take command of the second or supporting line, consisting of three companies of the Thirty-second Georgia regiment, First regiment Georgia regulars, Major Wayne, and detachment from Fourth Georgia Cavalry, Lieutenant-Colonel John L. Harris, to act as circumstances might require. Colonel Harrison at 3.30 A. M. moved forward his line of battle, formed parallel with the enemy's breastworks. His attacking force consisted of seven companies of his own regiment, which formed his right wing, and Bonaud's battalion and the Forty-seventh Georgia regiment, Colonel A. C. Edwards, which formed his left wing. His line of battle extended about 400 yards in length, preceded by a line of skirmishers of double that front and 300 yards in advance. The Stono River road, with hedges on both sides of it, cut his line of battle in two. . . . Colonel Harrison then ordered the charge, and his line moved steadily and sternly across the field, met and drove in the enemy's skirmishers, and advanced upon their breastworks. . . .

“ In the mistiness of the morning, the smoke resting upon the ground, I was unable to see his troops, and, supposing from the continuance of the rapid fire on both sides that Colonel Harrison had encountered too heavy a force, I ordered the advance of the entire reserve to his support. . . . But while our line advanced steadily and rapidly under a severe fire, which it had to endure with loss without returning, before we reached Colonel Harrison that gallant officer and the splendid troops under him, bravely led by their officers, had swept the enemy's lines, and his skirmishers had pushed beyond. . . .

“ At night the enemy quietly withdrew to the protection of their gun-

boats, and next day embarked their forces, burning their commissary stores ashore.

JOHN JENKINS, *Major Cavalry.*"

[Telegram.]

FORT SUMTER, July 7, 1864, 4 P. M.

Captain W. F. NANCE, *A. A.-General:*

The enemy continue a heavy fire on us. Their evident intention is to destroy our boom and our defenses against assault, as also to break through the gorge-wall. In the first part of their plan they have to some extent succeeded. The fire is quite as damaging as any bombardment since the year commenced. We have no labor to repair. Can't you send me fifty more men?

JOHN C. MITCHEL,

*Captain, commanding.*

[Indorsement.]

HEAD-QUARTERS FIRST MILITARY DISTRICT, }  
CHARLESTON, July 7, 1864. }

Respectfully forwarded for information of department. I have replied to Captain Mitchel that I have no force of laborers or soldiers to send him.

R. S. RIPLEY,

*Brigadier-General, commanding.*

[Despatch.]

HEAD-QUARTERS FIRST MILITARY DISTRICT, }  
CHARLESTON, S. C., July 20, 1864. }

CAPTAIN: Huguenin will be over as soon as he can cross with safety. Keep the garrison in good spirits. There is no danger yet, if all do their duty as you and Mitchel have done. Huguenin will be equal to the emergency. Show this to Huguenin, and tell him to report his arrival by telegraph. Give him all the necessary information when he arrives.

Your obedient servant,

WM. F. NANCE, *A. A.-G.*

Captain JOHN JOHNSON,

*Engineer, Fort Sumter.*

---

## CHAPTER XII.

CHARLESTON, S. C., Dec. 31, 1864.

LIEUTENANT-GENERAL W. J. HARDEE:

*Commanding Depart. South Carolina, Georgia, and Florida:*

GENERAL: . . . You will apply to the defense of Charleston the

same principle applied to that of Savannah; that is, defend it as long as compatible with the safety of your forces. Having no reason at present to expect succor from an army of relief, you must save your troops for the defense of South Carolina and Georgia.

The fall of Charleston would, necessarily, be a terrible blow to the Confederacy; but its fall with the loss of its brave garrison would be still more fatal to our cause.

G. T. BEAUREGARD,  
General.

[From the *Southern Historical Society Papers*.]

*Reminiscences of Torpedo Service in Charleston Harbor, by W. T. Glassel, Commander of Confederate States Navy.*

. . . . On the occasion of the attack upon the blockading squadron (making the attack at night), if I could have had any influence we should not have fired a gun, but trusted to the effect of iron rams at full speed. It was thought, though, by older and perhaps wiser officers that this would have been at the risk of sinking our iron-clads together with the vessels of the enemy. I have ever believed there was no such danger to be apprehended; and if there was, we had better have encouraged it than to have made the fruitless attempt which we did, only frightening the enemy and putting them on their guard for the future.

It was my part, on that memorable morning, to aim and fire one effective shell into the Keystone State while running down to attack us, which (according to Captain LeRoy's report), killing 21 men and severely wounding 15, caused him to haul down his flag in token of surrender.

The enemy now kept at a respectful distance while preparing their iron-clad vessels to sail up more closely. Our Navy Department continued slowly to construct more of these rams, all on the same general plan, fit for little else than harbor defense. The resources of the United States being such that they could build ten iron-clads to our one, and of a superior class, almost invulnerable to shot or shell, I had but little faith in the measures we were taking for defense.

Captain F. D. Lee, of the Engineers, was employed constructing torpedoes to be placed in the harbor, and called my attention to the subject. It appeared to me that this might be made an effective weapon to use offensively against the powerful vessels now being built. An old hulk was secured, and Captain Lee made the first experiment as follows: A torpedo made of copper and containing thirty or forty pounds of gunpowder, having a sensitive fuze, was attached by means of a socket to a long pine pole. To this weights were attached, and it was suspended horizontally beneath a rowboat by cords from the bow and stern—the torpedo projecting eight or ten feet ahead of the boat and six or seven

feet below the surface. The boat was then drawn toward the hulk till the torpedo came in contact with it and exploded. The result was the immediate destruction of the old vessel and no damage to the boat.

I was now convinced that powerful engines of war could be brought into play against iron-clad ships. I believed it should be our policy to take immediate steps for the construction of a large number of small boats suitable for torpedo service, and make simultaneous attacks, if possible, before the enemy should know what we were about.

. . . . I got rowboats from my friend, Mr. George A. Trenholm, and at his expense equipped them with torpedoes for a practical experiment against the blockading-vessels at anchor off the bar.

. . . . I was allowed, some time after this, to go out alone with one of these boats and a crew of six men, to attack the United States ship Powhatan with a fifty-pound torpedo of rifle-powder attached to the end of a long pole, suspended by wires from the bow and stern beneath the keel of the boat, and projecting eight or ten feet ahead and seven feet below the surface.

I started out with ebb-tide in search of a victim. I approached the ship about one o'clock. The young moon had gone down, and every thing seemed favorable, the stars shining over head and sea smooth and calm. The bow of the ship was toward us and the ebb-tide still running out. I did not expect to reach the vessel without being discovered, but my attention was, no matter what they might say or do, not to be stopped until our torpedo came in contact with the ship. My men were instructed accordingly. I did hope the enemy would not be alarmed by the approach of such a small boat so far out at sea, and that we should be ordered to come alongside. In this I was disappointed. When they discovered us, two or three hundred yards distant from the port bow, we were hailed and immediately ordered to stop and not come nearer. To their question, "What boat is that?" and numerous others I gave evasive and stupid answers, and, notwithstanding repeated orders to stop and threats to fire on us, I told them I was coming on board as fast as I could, and whispered to my men to pull with all their might. I trusted they would be too merciful to fire on such a stupid set of idiots as they must have taken us to be.

My men did pull splendidly, and I was aiming to strike the enemy on the port side, just below the gangway. They continued to threaten and to order us to lay in our oars, but I had no idea of doing so, as we were now within forty feet of the intended victim. I felt confident of success, when one of my trusted men, from terror or treason, suddenly backed his oar and stopped the boat's headway. This caused the others to give up apparently in despair. In this condition we drifted with the tide past the ship's stern, while the officer of the deck, continuing to ply me with embarrassing questions, gave order to lower a ship's boat to go for us.

The man who backed his oar had now thrown his pistol overboard, and reached to get that of the man next to him for the same purpose. A number of men by this time were on deck with rifles in hand. The torpedo was now an incumbrance to retard the movements of my boat.

I never was rash or disposed to risk my life or that of others without large compensation from the enemy. But to surrender thus would not do. Resolving not to be taken alive till somebody at least should be hurt, I drew a revolver and whispered to the men at bow and stern to cut loose the torpedo.

This being quickly done, they were directed quietly to get the oars in position and pull away with all their strength. They did so. I expected a parting volley from the deck of the ship, and, judging from the speed with which the little boat travelled, you would have thought we were trying to outrun the bullets which might follow us. No shot was fired. I am not certain whether their boat pursued us or not. We were soon out of sight and beyond their reach, and I suppose the captain and officers of the Powhatan never have known how near they came to having the honor of being the first ship ever blown up by a torpedo-boat.

I do not think this failure was from any fault or want of proper precaution of mine. The man who backed his oar and stopped the boat at the critical moment declared afterward that he had been terrified so that he knew not what he was doing. He seemed to be ashamed of his conduct, and wished to go with me into any danger. His name was James Murphy, and he afterward deserted to the enemy by swimming off to a vessel at anchor in the Edisto River.

I think the enemy must have received some hint from spies, creating a suspicion of torpedoes, before I made this attempt. I got back to Charleston after daylight next morning, with only the loss of one torpedo, and convinced that steam was the only reliable motive-power.

Commodore Tucker having been ordered to command the naval forces at Charleston, torpedoes were fitted to the bows of iron-clad rams for use should the monitors enter the harbor.

My esteemed friend, Mr. Theodore Stoney of Charleston, took measures for the construction of the little cigar-boat *David* at private expense; and about this time I was ordered off to Wilmington as an executive officer to attend to the equipment of the iron-clad *North Carolina*. She drew so much water it would have been impossible to get her over the bar, and consequently was only fit for harbor defense.

In the mean time, the United States fleet, monitors and Ironsides, crossed the bar at Charleston and took their comfortable positions protecting the army on Morris Island and occasionally bombarding Fort Sumter.

. . . I had everything ready for the experiment, and only waited for

a suitable night, when orders came requiring me to take all the men from the North Carolina by railroad to Charleston immediately. An attack on that city was expected. I lost no time in obeying the order, and was informed, on arriving there, that "my men were required to reinforce the crews of the gunboats, but there was nothing in particular for me to do." In a few days, however, Mr. Theodore Stoney informed me that the little cigar-boat built at his expense had been brought down by railroad, and that if I could do anything with her he would place her at my disposal. On examination I determined to make a trial. She was yet in an unfinished state. Assistant Engineer J. H. Toombs volunteered his services, and all necessary machinery was soon fitted and got into working order, while Captain F. D. Lee gave me his zealous aid in fitting on a torpedo. James Stuart (alias Sullivan) volunteered to go as fireman, and afterward the services of J. W. Cannon as pilot were secured. The boat was ballasted so as to float deeply in the water, and all above painted the most invisible color (bluish). The torpedo was made of copper, containing about one hundred pounds of rifle powder, and provided with four sensitive tubes of lead containing explosive mixture; and this was carried by means of a hollow iron shaft projecting about fourteen feet ahead of the boat and six or seven feet below the surface. I had also an armament on deck of four double-barrel shot-guns and as many navy revolvers; also, four cork life-preservers had been thrown on board, and made us feel safe.

Having tried the speed of my boat and found it satisfactory (six or seven knots an hour), I got a necessary order from Commodore Tucker to attack the enemy at discretion, and also one from General Beauregard. And now came an order from Richmond that I should proceed immediately back to rejoin the North Carolina at Wilmington. This was too much! I never obeyed that order, but left Commodore Tucker to make my excuses to the Navy Department.

The 5th of October, 1863, a little after dark, we left Charleston wharf and proceeded with the ebb-tide down the harbor.

A light north wind was blowing and the night was slightly hazy, but starlight, and the water was smooth. I desired to make the attack about the turn of the tide, and this ought to have been just after nine o'clock, but the north wind made it run out a little longer.

We passed Fort Sumter and beyond the line of picket-boats without being discovered. Silently steaming along just inside the bar, I had a good opportunity to reconnoitre the whole fleet of the enemy at anchor between me and the camp-fires on Morris Island.

Perhaps I was mistaken, but it did occur to me that if we had then, instead of only one, just ten or twelve torpedoes to make a simultaneous attack on all the iron-clads, and this quickly followed by the egress of our rams, not only might this grand fleet have been destroyed, but the 10,000 troops on Morris Island been left at our mercy. Quietly manœuv-

ring and observing the enemy, I was half an hour more waiting on time and tide. The music of drum and fife had just ceased, and the nine o'clock gun had been fired from the admiral's ship as a signal for all unnecessary lights to be extinguished and for the men not on watch to retire for sleep. I thought the proper time for attack had arrived.

The admiral's ship, *New Ironsides* (the most powerful vessel in the world), lay in the midst of the fleet, her starboard side presented to my view. I determined to pay her the highest compliment. I had been informed, through prisoners lately captured from the fleet, that they were expecting an attack from torpedo-boats, and were prepared for it. I could therefore hardly expect to accomplish my object without encountering some danger from riflemen, and perhaps a discharge of grape or canister from the howitzers. My guns were loaded with buckshot. I knew that if the officer of the deck could be disabled to begin with, it would cause them some confusion and increase our chance for escape; so I determined that if the occasion offered I would commence by firing the first shot. Accordingly, having on a full head of steam, I took charge of the helm, it being so arranged that I could sit on deck and work the wheel with my feet. Then, directing the engineer and firemen to keep below and give me all the speed possible, I gave a double-barrel gun to the pilot, with instructions not to fire until I should do so, and steered directly for the monitor. I intended to strike her just under the gangway, but the tide, still running out, carried us to a point nearer the quarter. Thus we rapidly approached the enemy. When within about 300 yards of her a sentinel hailed us: "Boat ahoy! boat ahoy!" repeating the hail several times very rapidly. We were coming toward them with all speed, and I made no answer, but cocked both barrels of my gun. The officer of the deck next made his appearance, and loudly demanded, "What boat is that?" Being now within forty yards of the ship and plenty of headway to carry us on, I thought it about time the fight should commence, and fired my gun. The officer of the deck fell back mortally wounded (poor fellow!), and I ordered the engine stopped. The next moment the torpedo struck the vessel and exploded. What amount of direct damage the enemy received I will not attempt to say. My little boat plunged violently, and a large body of water which had been thrown up descended upon her deck and down the smokestack and hatchway.

I immediately gave orders to reverse the engine and back off. Mr. Toombs informed me then that the fires were put out and something had become jammed in the machinery so that it would not move. What could be done in this situation? In the mean time, the enemy, recovering from the shock, beat to quarters, and general alarm spread through the fleet. I told my men I thought our only chance to escape was by swimming, and I think I told Mr. Toombs to cut the water-pipes and let the boat sink.



Then taking one of the cork floats, I got into the water and swam off as fast as I could.

The enemy, in no amiable mood, poured down upon the bubbling water a hailstorm of rifle- and pistol-shots from the deck of the Ironsides and from the nearest monitor. Sometimes they struck very close to my head, but, swimming for life, I soon disappeared from their sight, and found myself all alone in the water. I hoped that with the assistance of flood-tide I might be able to reach Fort Sumter, but a north wind was against me, and after I had been in the water more than an hour I became numb with cold and was nearly exhausted. Just then the boat of a transport schooner picked me up, and found, to their surprise, that they had captured a rebel. . . .

[The cigar-boat David, which carried the torpedo on this expedition, was designed entirely by St. Julien Ravenel, M. D., of Charleston, and constructed under his direction, the funds only having been provided for by Mr. T. D. Stoney, as stated in the note on page xxx of Appendix B.]

---

CHAPTER XIII.

*Destruction of the Monitor Patapsco by a Torpedo in the Channel off Fort Sumter.*

FLAGSHIP HARVEST MOON,  
CHARLESTON ROADS, S. C., Jan. 16, 1865. }

SIR: I have the honor to submit to you a report of the circumstances connected with the loss of the iron-clad Patapsco, under my command, at 8.10 P. M. on the 15th inst., by a torpedo.

On the evening of the 15th inst. we cast off from our buoy at the lower anchorage and proceeded up to our usual station as advanced monitor. We rounded to, and I immediately called alongside the officers in charge of picket- and scout-boats. I directed them to select as many boats as had grapnels, and to push them up the harbor, using every effort to discover torpedoes or obstructions, the remaining boats to take position on our beams and quarters, keeping within 100 or 200 yards of the vessel.

The commanding officers of the tugboats were ordered to keep about the same distance ahead and on each bow. The object in assigning these positions was to avoid observation by the enemy and drawing their fire. I then allowed the Patapsco to drift up with the tide until nearly in a line from Sumter to Moultrie, the boats and tugs keeping in their respective positions. From this point, which was the highest obtained, we steamed down to within a few yards of the Lehigh buoy, then stopped and allowed the vessel to drift up, keeping in sight the before-mentioned

buoy. On proceeding down the third time, and when within between 200 and 300 yards of the buoy, we struck and exploded a large torpedo or torpedoes, about thirty feet from the bow and a little on the port side.

The instant I discovered that we had been struck I gave the order to start the pumps. In an instant more I discovered that the whole forward part of the vessel was submerged, and, there being no possible chance to save the vessel, I then gave the order to man the boats; but before even an effort could be made to do so the vessel had sunk to the top of the turret.

The boat which hung at the port davits abaft the turret was afloat before Acting Ensign A. P. Bashford and the quartermaster of the watch, who were with me on the port side of the turret, could get into the boat to clear the falls. It was by great exertions that Mr. Bashford and the quartermaster succeeded in clearing the boat from the head of the davits. When I left the turret to get into the boat I could discover nobody on board, and the water was at the time ankle-deep on the turret. My first thought after this providential escape was the safety of such of the survivors as we could pick up. I had the good fortune of saving eleven of the crew. Owing to the disposition of the boats and tugs, which I had previously made to provide against accidents, all those persons who had escaped up from below, and those who were on deck, were rescued, to the number of 43—5 officers and 38 men. I would respectfully state that at no time did I apprehend any danger whatever from torpedoes, as it was generally supposed they were sunk above the line from Moultrie to Sumter, and therefore did not conceive that the safety of the vessel or the lives of those on board were being jeopardized. . . .

Hon. GIDEON WELLES,

*Secretary of Navy.*

S. P. QUACKENBUSH,

*Lieutenant-Commander U. S. N.*

[Some additional particulars, gathered from other official reports, are as follows: Sixty-two, officers and men, were lost. The position of the wreck, marked by the smoke-pipe projecting above water, was about 800 yards from Sumter and 1200 from Moultrie. "The Patapsco had her torpedo-fenders and netting stretched as usual around her. Three boats with drags had preceded her, searching to some depth the water they had passed over, while steam-tugs and several boats were in different positions on the bow, beam, and quarter."]

*Charleston and its Defenses.*

[This paper was written, at the request of Hon. W. A. Courtenay, mayor of Charleston, by Brigadier-General R. S. Ripley, and printed in the *Charleston Year-Book* for 1885. It has been found necessary to abridge the paper to the extent of a few pages, but no opinion of this

distinguished officer, who was so prominent in the military operations before Charleston, has been omitted.]

. . . . Early in January, 1862, the continued presence of the Federal force at Port Royal being an assured fact, General Lee directed that Charleston and its approaches should be fortified to as full an extent as possible by land, as well as on the sea-front, and the work was immediately commenced.

The Confederates were deficient in everything. There were no engineer officers, no laborers, no money, and everything had to be improvised from such resources as could be collected. The nature of the locality rendered the necessary work of great development, including all the surroundings of Charleston, extending from the inland channel opposite Christ Church parish, across that parish to the Wando River; across Charleston Neck; and from the right bank of the Ashley River, through St. Andrew's parish, to the Stono, and on the banks of that river and across James Island to the channels on its east, near Secessionville.

Engineer officers were first supplied from the young cadets of the Citadel Academy at Charleston, and the gentlemen of the country were asked to send their negroes to the work. Among those who set the example of contributing their force were the Hon. Charles Macbeth, mayor, Governor Aiken, the Hon. Alfred Huger, Messrs. James Rose, George A. Trenholm, and Theodore D. Wagner, and their example was followed by many others. In a short time stalwart field-hands, accompanied by their owners and overseers, were available in large numbers.

The traces of the works to be constructed were determined at district head-quarters and immediately commenced. As Charleston had been taken by the British troops in the old Revolutionary War by approaches on Charleston Neck, it was determined to close that avenue effectually. A strong line of fortifications was built across the peninsula from river to river at once. It was intended to cut a canal from the Cooper to the Ashley, some two miles in advance of this, with complete fortifications. In case of attack the timber in front could be readily felled to cover the approaches with abattis, while the whole system could be flanked by fire from gunboats in either one or the other river. The interior line was finished in a few weeks.

At about the same time a strong *crémallière* line was constructed across James Island from a point on Wappoo Cut eastward to New Town Creek, and from the eastern shores of the creek to the vicinity of Secessionville. This line was intended for the protection of a relieving force should it be necessary to assemble one in the event of the enemy attempting to reduce the works on Cole's Island, which meantime were being increased in extent and armament.

Soon after a line was built across Christ Church parish from Elliott's

Creek, a branch of the Wando, to Copahee Sound. Here advantage was taken of a deep draining-ditch which had been cut for agricultural purposes. It was proposed to fell the timber in advance of the line in case of necessity. No attempt was made to fortify Morris Island at this time, as it was deemed very improbable that the enemy would attempt any approach along that island so long as Cole's Island and the Stono River were held by the Confederates.

The force of negroes furnished by the planters and employed on these various works was over 6000, and they were at work during the best part of January and February, 1862.

At this time Colonel L. M. Hatch was stationed with his regiment at Secessionville. His especial duty was to watch the creeks and interior water-approaches. He conceived the idea of fortifying the neck of the latter peninsula, although the work was not immediately necessary nor likely to be so long as Cole's Island was held. But his suggestions were approved, and with the labor of his regiment he constructed the priest-cap work across the neck with flanking arrangements, built a strong bridge to connect the northern end of the peninsula with the main island, and erected an observatory which commanded an extensive view of the approaches to Charleston from the south-east. It proved very fortunate that this work was early accomplished.

Up to this time the preparations of St. Andrew's parish consisted in arrangements to connect the creeks and water-courses in such a manner as to interpose inundations to a possible approach, and the construction of a few batteries at different points on the Stono. . . .

The distance between Castle Pinckney and Fort Johnson was about 3600 yards, and for the defense of these obstructions it was decided to build another battery on the Middle Ground. The foundation was secured by a large cribwork eighty feet square, filled in with rubbish and sand, faced on the outside with palmetto logs. This work was rapidly constructed and armed with four 10-inch guns.<sup>1</sup> A considerable portion of the proposed piling was done under the superintendence of Captain Francis J. Porcher, but subsequently events prevented the obstructions from being completed.

In March, 1862, General Lee was relieved of the command of the department, and was succeeded by General Pemberton. The latter had peculiar ideas, and he speedily and peremptorily ordered the evacuation of Cole's Island and opened the Stono River to the enemy. He allowed some little time for the commencement of works for the defense of the Stono at a higher point, and a strong redoubt was erected at the turn of the river near Wappoo, and called Fort Pemberton.

Representations were immediately made of the necessity of fortifying Morris Island, but General Pemberton was averse to entertaining them. After some time he visited the island, and rode along its beach

<sup>1</sup> Reduced very soon to two 10-inch.—J. J.

to the point where Battery Wagner was built, and selected the position for the only work which he would permit on the island. It was remarked at the time that if the fortification of the island was to be confined to a single work, this was not the point, inasmuch as the work there must be entirely self-sustaining; whereas, if a strong fortification were constructed at Cumming's Point and the sandhills levelled, its batteries could sweep the beach, while in case of attack its whole front could be protected in flank by the batteries on Sullivan's Island and Fort Johnson. This was evident, but General Pemberton was obdurate, and the work was ordered at Wagner. Meantime, all the defenses had been strengthened, and their armaments been increased by guns cast at Richmond. The number of engineer officers had been increased. It was determined to add to the works on Sullivan's Island and connect the island with Mount Pleasant by a bridge. Battery Bee was constructed by an accomplished engineer, Captain George E. Walker, who was careful to build his works with especial reference to the effect of modern artillery. . . .

The effect of the abandonment of the Stono was soon apparent. A light-draft steamer was carried off by a negro named Smalls, and the information given to the Federal blockading fleet. The mouth of the Stono was entered at once, and guarded by two Federal gunboats.

In June, 1862, the Federal general, Benham, with a force about 10,000 strong, landed on James Island, with apparent determination to stay. A few skirmishes took place, but the Federal commander had heard much of the danger of the malarious atmosphere of James Island, and wanted to secure Secessionville as a place of arms and a sanitarium. So he attacked it with a heavy force on 16th of June, and was so speedily and thoroughly repulsed that he gave up the attempt and retired to Port Royal.

Colonel Hatch's work had done good service. General Pemberton conceived an idea of abandoning all the advanced works for the defense of Charleston, including Forts Sumter and Moultrie, and mounting the guns on the city wharves. He recommended this course in a letter addressed to the Secretary of War through the adjutant-general. Then, as if to prepare for the bombardment which he proposed to invite, he commenced a few bombproofs in Charleston by covering certain cellars which had been uncovered in the great fire of December, 1861. However, his notions were not approved at Richmond, and the works which had been commenced were well and solidly finished during the summer of 1862—notably Battery Bee on Sullivan's Island and Battery Wagner on Morris Island, the former under charge of Captain George E. Walker, and the latter of Captain Langdon Cheves. The works defending the north-eastern extremity of Sullivan's Island at Battery Marshall were enlarged and strengthened.

At the close of the summer of 1862, General Pemberton was relieved

from the command of the department, and during the next autumn and winter work was continually going on in strengthening the fortifications constructed; but the greatest attention was paid to armament, for it was pretty well established that Charleston was to be attacked by the newly-invented monitors at an early date. The enemy, however, had held on to his lodgment in the Stono and on Folly Island, and there was continually danger of his forcing Lighthouse Inlet and attacking by Morris Island. The necessity of preparations to prevent this was frequently urged, but lack of armament delayed action. At last the capture of the Federal gunboat *Isaac Smith* in the Stono furnished a few guns, and the construction of seven single-gun batteries to protect the inlet was ordered. The order was executed to some extent, and the batteries were armed, but the engineers were very dilatory in completing their work, and it was a long time before a battery was ready for efficient service. Early in April, 1863, Admiral DuPont made his attack with the *Ironsides* frigate, seven monitors, and the *Keokuk*, iron-clads, and they were repulsed after a spirited action of two hours and twenty-five minutes' duration. . . .

The enemy retired from the harbor, but was still in force on Folly Island. The condition of the works at Lighthouse Inlet became again a subject for solicitude. The single-gun batteries ordered some time previously were not ready for service, and the chief engineer, Colonel Harris, to whom General Beauregard had especially confided all matters of fortification, was occupied in the construction of interior works and perfecting the lines in St. Andrew's parish with a force of negroes impressed for the service. His idea appeared to be that little could be done by the work of the troops, and he proposed to establish a battery to command the passage of the inlet by long-range fire from Black Island, which it was proposed to connect with James Island by a foot-bridge. But little was done at this work, and meantime the works at the south end of Morris Island were neglected.

To meet the emergency, Captain John C. Mitchel, of the First South Carolina Artillery, was placed in charge of them with two companies, and soon provided them with magazines and prepared them for service, such as they were. The armament was increased by four 10-inch mortars, and as the enemy in the early part of June showed some signs of work on Little Folly Island, he opened fire and shelled their position at intervals, interfering seriously with such works as they were constructing. However, General Beauregard, who returned to Charleston about the middle of June, disapproved of this, and on the 20th ordered that the matter be left entirely in charge of Colonel Harris and his officers; and so it was. Nothing whatever was done on the works, and little on the proposed foot-bridge, and nothing for the fortification or armament of Black Island. Meanwhile, the enemy had full opportunity to construct his works at leisure, which he did skilfully and secretly, so that his inten-

tions were not fully developed until the 8th of July. The department was denuded of troops, large forces having been sent to the West, and the necessity was urgent. The Federal fire was heavy, the Stono was full of transports and men-of-war, and it was evident the enemy intended to force the passage. Efforts were made to concentrate a force to oppose him, but time was wanting, and on the morning of the 10th of July he opened on the defenses of Lighthouse Inlet with land-batteries of some forty-five guns of heavy calibre, and many more from the blockading fleet. The result was speedy, and the Confederates were soon silenced. The Federals then crossed in force under cover of their artillery and made good their footing on the island.

Thenceforward, the construction of defensive works on Morris Island was connected with the defense of Battery Wagner. Lieutenant-Colonel Harris, chief engineer, well supported by efficient engineer officers, did as much as could be done to make good the defense and compensate for the crying neglect which enabled the enemy so easily to establish his attack on that line of approach. While this was going on, defensive works were pushed on Sullivan's Island; Battery Bee was connected with Fort Moultrie, which work was still further protected by covering its masonry, and it was furnished with bombproof accommodations. It was also connected with Battery Beauregard. Four batteries were built to the east of that work to command the centre ground and connect with Battery Marshall.

Fort Sumter also claimed attention. The enemy speedily established long-range rifle-batteries against it, and soon demonstrated that it was only a question of time when the fort would lose its offensive character. The casemates were filled with sand from the parade, the quarters were protected as well as possible, merlons were constructed, and the removal of the armament was carried on continuously while Battery Wagner held out. Efforts were energetically made to prepare the interior defenses, so as to render the reduction of Morris Island as barren of benefit to the enemy as possible; and they were successful. On the 7th of September Battery Wagner was evacuated. Although the enemy made strenuous efforts thereafter to advance, and especially to capture Fort Sumter, he was invariably foiled.

The works of defense around Charleston were continued throughout the war until its close, but were mostly confined to the perfection and strengthening of those already constructed. Some new lines were built on James Island and St. Andrew's parish, which are all shown upon the map up to its date; and they cover the approaches to Charleston. With the exception of a spasmodic attempt to overwhelm Fort Sumter, and an abortive attack upon Battery Simkins and Fort Johnson, the siege of Charleston degenerated into a blockade, in which the Federal fleet was assisted by the Federal batteries on Morris Island, and a useless though annoying bombardment of the city of Charleston at long range.

The work of the engineers went on, however, notably at Fort Sumter, which the enemy endeavored to crush continually. It was well supplied at night, and the works of the interior retrenchment well and efficiently carried on under Captain John Johnson, an able engineer, so that it became almost impregnable against an assault, and its garrison lived under the terrific cannonade to which it was subjected in comparative comfort.

The foregoing memoranda on the fortifications of Charleston it is feared are incomplete, having been written entirely from memory, but it is hoped that they will explain the map to which they refer, and inform the reader of the general history and object of the works therein indicated. The object of the fortifications was in great part accomplished, and the city had a partial immunity during the strife. Indeed, had it not been for two notably egregious errors, it may be believed that Charleston would have suffered few of the material hardships of the war.

The first of these was the abandonment of Cole's Island, by which the enemy was practically invited to make his base within a few miles of the city; and the second was the neglect to prevent the passage of Light-house Inlet, permitting him to make his attack by Morris Island.

R. S. RIPLEY.

### *Harbor Obstructions.*

[The following report of Lieutenant Talcott is believed to be correct in all essential particulars, having been examined and corroborated by officers of the Confederate army engaged in the defense of Charleston during the period to which it refers. (*Supplementary Report of Major-General Q. A. Gillmore, Operations against Charleston, S. C.*)]

HEAD-QUARTERS DEPARTMENT OF THE SOUTH, }  
HILTON HEAD, S. C., April 12, 1865. }

Major-General Q. A. GILLMORE,

*Commanding Department of the South, Hilton Head, S. C.:*

GENERAL: In compliance with instructions received from you, I have the honor to submit the following report concerning the obstructions which have been and now are in existence in Charleston harbor. The information embodied in the report has been derived in part from the evidence of citizens of Charleston who have been concerned, directly or indirectly, with the obstructions, and partly from my own observations. . . .

In January, 1865, there were sixteen barrel torpedoes placed between Forts Sumter and Moultrie, extending across the main ship channel. They were anchored with a single mushroom anchor to each, with such length of rope as to leave them four or five feet below the surface of the water at low tide. The last ones were placed the night the monitor



Patapsco was destroyed, and she was blown up by one of them. Nine of the sixteen have since been exploded or taken up. Some of the others have probably broken loose and gone adrift. The U. S. Coast Survey steamer Bibb exploded one in March, 1865, *without damage*, while running the main ship-channel in twenty-nine feet of water. Seven were also placed in Rebellion Roads, on a line from Castle Pinckney to Battery Bee. There were also three large boiler-iron torpedoes placed—one off Fort Wagner at the spot marked L on the chart, one in Rebellion Roads, and one in Ashley River off White Point. It was intended that they should be exploded by galvanic battery from the shore, but the exploding cables were broken in placing them, and they were thereby rendered useless.

The only other obstructions in the harbor of which I could find any trace were in the shape of torpedo-rafts. These were composed of four round logs, 60 feet long, and about 5 feet from the lower end a square timber was bolted on the upper side to bind them together: 10 feet from the upper end, three timbers C D, about 14 inches square, were bolted to the lower side as floats. Cast-iron torpedoes, capable of containing from twenty-five to fifty pounds of powder, were fastened on to the upper ends of the timbers and at right angles to them. The rafts were anchored inclining up stream, so as to leave the torpedoes about three feet below the surface of the water at low tide, one anchor, I, leading from the lower end, and one from the float timbers. The enemy's steamer Marion ran upon one of these rafts in Ashley River in April, 1863, exploding two of the torpedoes and sinking her at once. Four sections were put down in Ashley River, opposite the Bath House, at right angles to the channel, and three sections in Hog Island Channel. . . .

The testimony of all the parties whom I examined agrees as regards the practicability of entering the harbor, so far as obstructions were concerned, at any time previous to November or December, 1864. The pilot of the Palmetto State (enemy's gunboat) states that on the night of the 7th of April, 1863, after the naval attack upon Fort Sumter, he took that vessel, drawing thirteen feet of water, down outside of Fort Sumter, and that, although the night was very dark and he had not run the channel for some time, he kept the south or main ship-channel and found no obstructions. A pilot who has been in the harbor during the entire war says that before the torpedoes were put down, in the winter of 1864-65, he would have had no hesitation, from fear of any obstructions, in taking any vessel which would come over the bar up to the city, following the main ship-channel. One of the blockade-runner pilots, who has frequently run them into Charleston, says that even after the torpedoes were placed he has brought in, in the night, a vessel drawing ten feet of water, running from Sullivan's Island to the channel next Fort Sumter to clear the rope obstructions, and passing over the

torpedo ground without any specific information as to their location, without even touching them. All parties agree that the only danger to be apprehended was from the enemy's shore-batteries. . . . It seems also that the channel next Fort Sumter was never really obstructed until the torpedoes were put down in the winter of 1864-65. While the three first-described obstructions were across the channel, a section was always kept in reserve to close up the gap, but it was anchored near Fort Johnson, and a vigorous push would have passed Fort Sumter before they could have placed it.

Those conversant with the force of the current between Forts Sumter and Moultrie are of the opinion that the only danger to be apprehended from the torpedoes placed there was just at slack water, as either upon the ebb or flood tide the current would keep them so far below the surface of the water as to prevent the possibility of any vessel touching them.

I am, general,

Very respectfully, your obedient servant,

(Signed)

ED. N. KIRK TALCOTT,

*Lieutenant First N. Y. Engineers.*

CHARLESTON, Aug. 3, 1865.

The foregoing report is correct as far as relates to the obstructions in this harbor during the war. There are slight errors in regard to dates, and also the object and character of the obstructions commenced with piles and rafts between Castle Pinckney and Fort Johnson. The work was, however, never completed, and they are immaterial.

(Signed)

R. S. RIPLEY.

[From the *Supplementary Report to Engineer and Artillery Operations, etc. of Major-General Gillmore.*]

*Condition of Fort Sumter, February, 1865.*

The following description by Major Suter, U. S. corps of Engineers, is based upon a personal examination of the work made by him in August, 1865:

"The extensive repairs and alterations made by the enemy render it difficult to form an exact idea of the damage done to the fort by our fire.

"The second tier of casemates has been entirely destroyed, with the exception of four casemates on the north-west face and two casemates on the north-east face. On the gorge and south-east faces the lower tier of casemates has probably been breached by direct fire, but the roofs and partition walls are probably still standing. On the north face it is probable that this tier of casemates were nearly entirely destroyed by reverse fire. On the north-west and north-east faces they are in tolerably good condition. On the north face the scarp-wall was cut down

to the level of the throats of the second tier of embrasures. On the north-east and north-west faces it is cut down generally to the roofs of the second tier of casemates. The upper casemates on these two fronts were destroyed, while the scarp-wall remained standing. The average height of the parapets exposed to direct fire is 25' above high-water mark.

"The measures resorted to by the enemy to hold the work after it had been virtually destroyed were to construct extensive and secure bombproofs under the ruins; to make good communications between the different parts of the work; to obstruct, as much as possible, the approaches to the work; and to provide means of defense in case of an assault. Bombproofs were built of 12'' timber, sheathed with 6'' plank, in rear of the gorge and south-east faces. They were apparently placed against the parade-wall. These bombproofs were arranged principally for quarters, having chimneys, windows, and ventilators. They were continuous, and about 330' in length. The width varied from 25 to 10 feet. On top were placed 6 to 10 feet of sand. These quarters were loopholed in such a manner that the men could fire from their bunks on to the parade of the fort. The commissary storehouse was in the bombproof on the gorge. On the north-west face the whole lower tier of casemates and four of the second tier were converted into bombproof quarters. Three casemates on the north face were included. The casemates were secured from falling in by an interior shell of wood arched at the top and strongly shored up with heavy timbers. About 8' of earth was placed on the casemate roofs, and all breaches in the scarp-wall were repaired with gabions. The embrasures were left open, affording light and ventilation. One gun was mounted in this bombproof, bearing toward the city, used only for firing at sunset. Near it was the principal magazine. Near the end of the north-east face are four casemates in a good state of preservation. They are closed in rear with timbers, and the scarp-wall is strengthened with a heavy face-cover. Three guns are mounted here, bearing toward Sullivan's Island. Earth was placed on top and in rear, making these casemates bombproof.

"From the north extremity of the gun-chamber runs a small gallery, opening into a room having loopholes bearing on the parade. Above this bombproof two casemates of the second tier remain. A great deal of earth has been placed on them. In rear of these casemates is a wooden bombproof. The roof slopes off to the rear, leaving an opening in front for the whole length. The earth on top is sustained in front by gabions. A ladder leads down from this bombproof into the gun-room.

"A long gallery leads from the gun-chamber to the bombproof in the north-west face. This gallery is 3' wide by 6' high. The roofs of the casemates are sustained by wooden arches. A similar gallery leads from the gun-chamber to the bombproof on the south-east face.

“Another gallery leads from the south-west face to the bombproof on the gorge. There are four entrances from the parade to the gorge bombproof, and two to the south-east bombproof.

“The entrance to the fort is on the north-west face. A new dock was built here, and a covered gallery 3½' high and 62' long leads from the sally-port through to the inside of the fort. This passage is closed at both ends by loopholed doors. In the north-west angle a flight of stairs leads from the parade to the rampart. In the south-west angle is an interior staircase. The means of egress at the east angle have already been described. On the inside is a ramp leading up from the parade to the end of the bombproof.

“In the south angle the interior of the fort was revetted vertically with gabions. A ladder leads from the parade to the rampart. The sides of the large bombproof in the centre of the gorge were also revetted vertically with gabions. A ramp and staircase lead to the rampart from both sides of this bombproof.

“The gorge and south-east faces are arranged for infantry defense. The banquette on the gorge consists generally of a platform of boards. At the east and west angles are small traverses, which were used to cover the five mountain-howitzers on the parapet during the day-time. They were also occupied by sharpshooters and lookouts. Small magazines for the howitzers are at each extremity of the south-east face. There are also three small traverses at the north-west angle. On the north-west, north, and north-east faces the débris of the upper casemates has assumed the natural slope, and protects the bombproofs and galleries on those faces from reverse fire. On the other two faces, however, a vertical wall of timber or gabions sustains the ruins. About 4' depth of sand has been removed from the parade and transferred to the ramparts to cover the bombproofs, etc.”

To provide against assault, a portion of the floating obstructions from the main channel was moved abreast of the north-east front and the two fronts breached by direct fire from Morris Island. This boom was to prevent the landing of parties from boats upon the ruins of those fronts, which formed one gradual and practicable slope from the crest of the débris to the water's edge. These slopes were also provided with fraise and wire entanglements, as shown on the plan, Plate III.

[I take pleasure in agreeing to the above as a correct account, with one or two exceptions.—J. J.]

*Supplementary List of Confederate Land-forces in Service on the Coast of South Carolina, 1861-65.*

The list to be found on pages cxli.-cxliii. of the Appendix of this work is generally correct, but, as it covers only a limited period of time, the subjoined information is given with greater comprehensiveness.

Together with the cadets of the S. C. Military Academy, the first companies of infantry (volunteers) sent to Morris Island, before the firing on the Star of the West, and present that day, Jan. 9, 1861, were the Vigilant Rifles, Capt. S. Y. Tupper, the German Riflemen, Capt. J. Small, and the Zouave Cadets, Lt. C. E. Chichester.

In the *Military Operations of Gen. Beauregard* full and authentic lists of all commands engaged in the reduction of Fort Sumter, April 12-14, 1861, will be found; but they are too lengthy to be repeated in this place.

For the remainder of 1861, for 1862-65, the returns of *War Records*, ser. 1, vols. vi., xiv., and xxviii., give the following organized commands in addition to those mentioned in this Appendix :

*Tennessee*.—Two regiments of D. S. Donelson's brigade.

*Florida*.—Kilcrease Artillery, Capt. F. L. Villepigue.

*Louisiana*.—4th battalion infantry, Lt.-Col. J. McEnery; Orleans Guard Artillery, Capt. G. le Gardeur, Jr.

*Virginia*.—Nelson Artillery, Capt. J. N. Lamkin; Caroline Artillery, Capt. T. R. Thornton; Turner Artillery, Capt. W. D. Leake.

*North Carolina* (J. R. Cooke's brigade).—15th regt., Col. H. A. Dowd; 27th, Col. J. A. Gilmer; 46th, Col. E. D. Hall; 48th, Col. R. C. Hill; one company of light artillery, Capt. Cooper.

*Georgia*.—Infantry: 46th regt., Col. P. H. Colquitt; 51st, Col. W. M. Slaughter; 47th, Col. G. W. M. Williams; 8th bat., Maj. B. F. Hunt; battalion, Maj. A. Bonaud; Legion, Col. W. P. Phillips.

Artillery: 22d bat., Col. W. R. Pritchard; Co. C of 12th bat., siege train, Maj. G. L. Buist; Chestatee, Capt. T. H. Bomar.

Cavalry: 5th regt., 21st, Maj. W. P. White, 2d battalion.

*South Carolina*.—Infantry: 1st regt. of rifles, Col. J. L. Branch; 1st regt., Col. J. Hagood; 10th, Col. A. M. Manigault; 11th, Col. W. C. Heyward; 12th, Col. R. G. M. Dunovant (Col. D. Barnes); 14th, Col. James Jones; 15th, Col. W. D. DeSaussure; 16th, Col. J. McCullough; 17th, Col. J. H. Means; 18th, Col. J. M. Gadberry; 22d, Col. J. Abney; 24th, Col. C. H. Stevens; 26th, Col. A. D. Smith; rifles, Col. L. M. Hatch; 3d battalion, Lt.-Col. G. S. James; 5th bat., Lt.-Col. J. V. Moore.

Cavalry: mounted regt., Col. W. E. Martin; 3d, Col. C. J. Colcock; 4th, Col. B. H. Rutledge; 6th, Col. H. K. Aiken; 1st bat., Lt.-Col. J. L. Black; 4th bat., Maj. W. K. Easley; 5th regt., Col. J. Dunovant; squadron, Capt. J. H. Tucker; Stono Scouts, Capt. J. B. L. Walpole; Rangers, Capt. M. J. Kirk; Rebel Troop, Capt. J. L. Seabrook.

Artillery: horse, Capt. W. L. Trenholm; Santee, Capt. C. Gaillard; Macbeth, Capt. R. Boyce; Beaufort, Capt. S. Elliot, Capt. H. M. Stuart; Waccamaw, Capt. J. Ward; siege train, Maj. C. Alston, Jr.; German, Capt. C. D. Werner, F. W. Wagener, F. Melchers; bat., Capt. T. B. Ferguson, Capt. F. F. Warley.

The 27th S. C. regt. organized, Sept. 30, 1863, by combining the Charleston battalion with Abney's Sharpshooters.







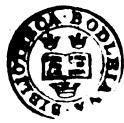

MO

Ca

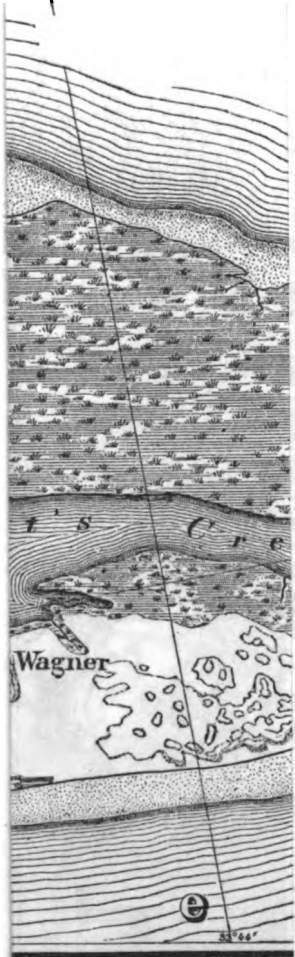



MO

C

# SIEGE OPERATIONS

ON

## MORRIS ISLAND - CHARLESTON WARREN

July 10th - Sept. 6th, 1863.

COMPILED FROM REPORTS BY CAPTAIN J. S. WILMORE, Commanding

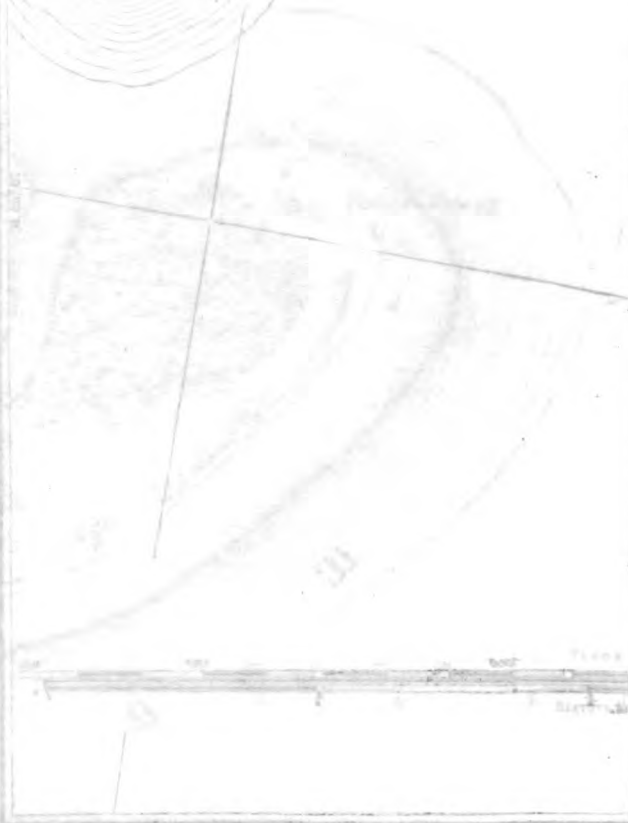
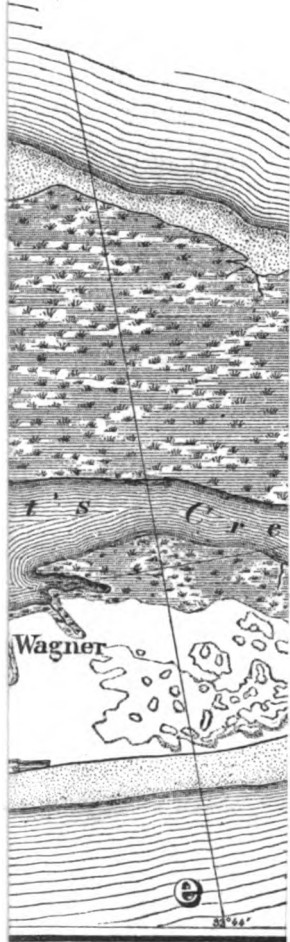



UNION BATTERIES - Fort Island - 7 guns  
 and mortar. Middle Island - 12 guns and  
 mortar. 60 guns of mortar. 1 gun  
 was mounted on the West side  
 from 1861 to 1862.  
 CONFEDERATE BATTERIES - South end of  
 Middle Island - 11 guns and mortar.  
 North end - 20 guns and mortar. This  
 position was captured in a few days  
 in 1862.  
 A small island, perpendicular of  
 the Confederates held in the island  
 in 1862, and captured in 1863.

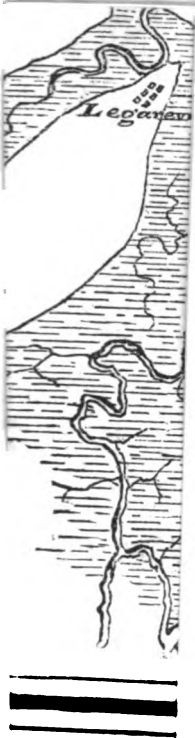









TIONS

harbor, 1865.

being omitted.

**FORT MARSHALL**

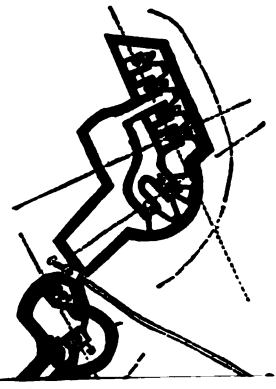

1 Fort 1802

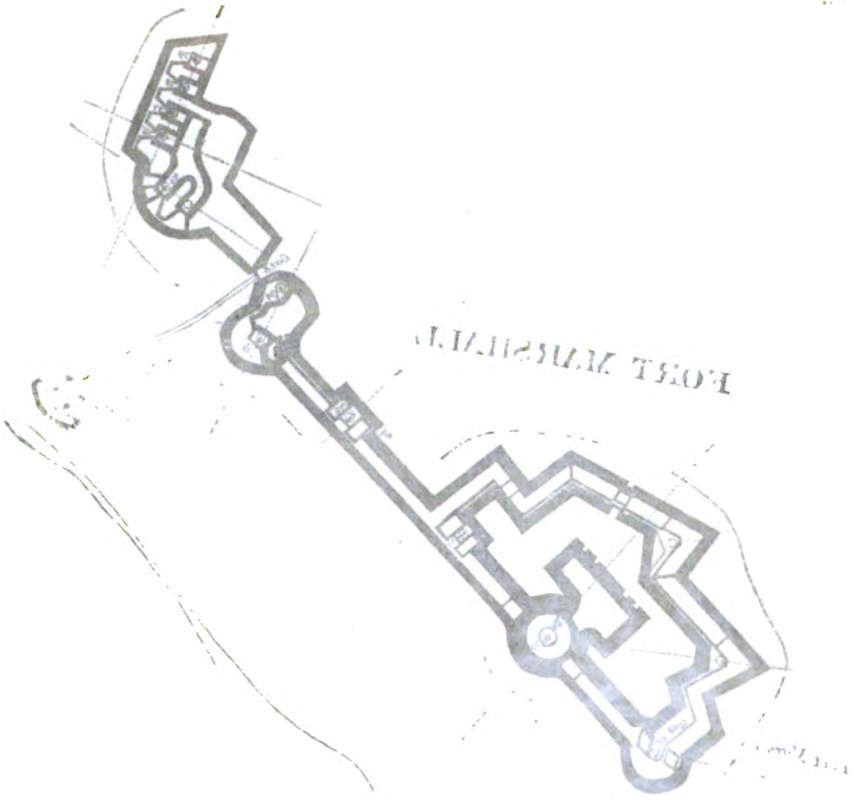

TO THE  
GENERAL ASSEMBLY

# REPORT OF THE

COMMISSIONERS OF THE  
LAND OFFICE



1880



18  
19  
20  
21  
22  
23  
24  
25  
26  
27  
28  
29  
30  
31  
32  
33  
34  
35  
36  
37  
38  
39  
40  
41  
42  
43  
44  
45  
46  
47  
48  
49  
50  
51  
52  
53  
54  
55  
56  
57  
58  
59  
60  
61  
62  
63  
64  
65  
66  
67  
68  
69  
70  
71  
72  
73  
74  
75  
76  
77  
78  
79  
80  
81  
82  
83  
84  
85  
86  
87  
88  
89  
90  
91  
92  
93  
94  
95  
96  
97  
98  
99  
100



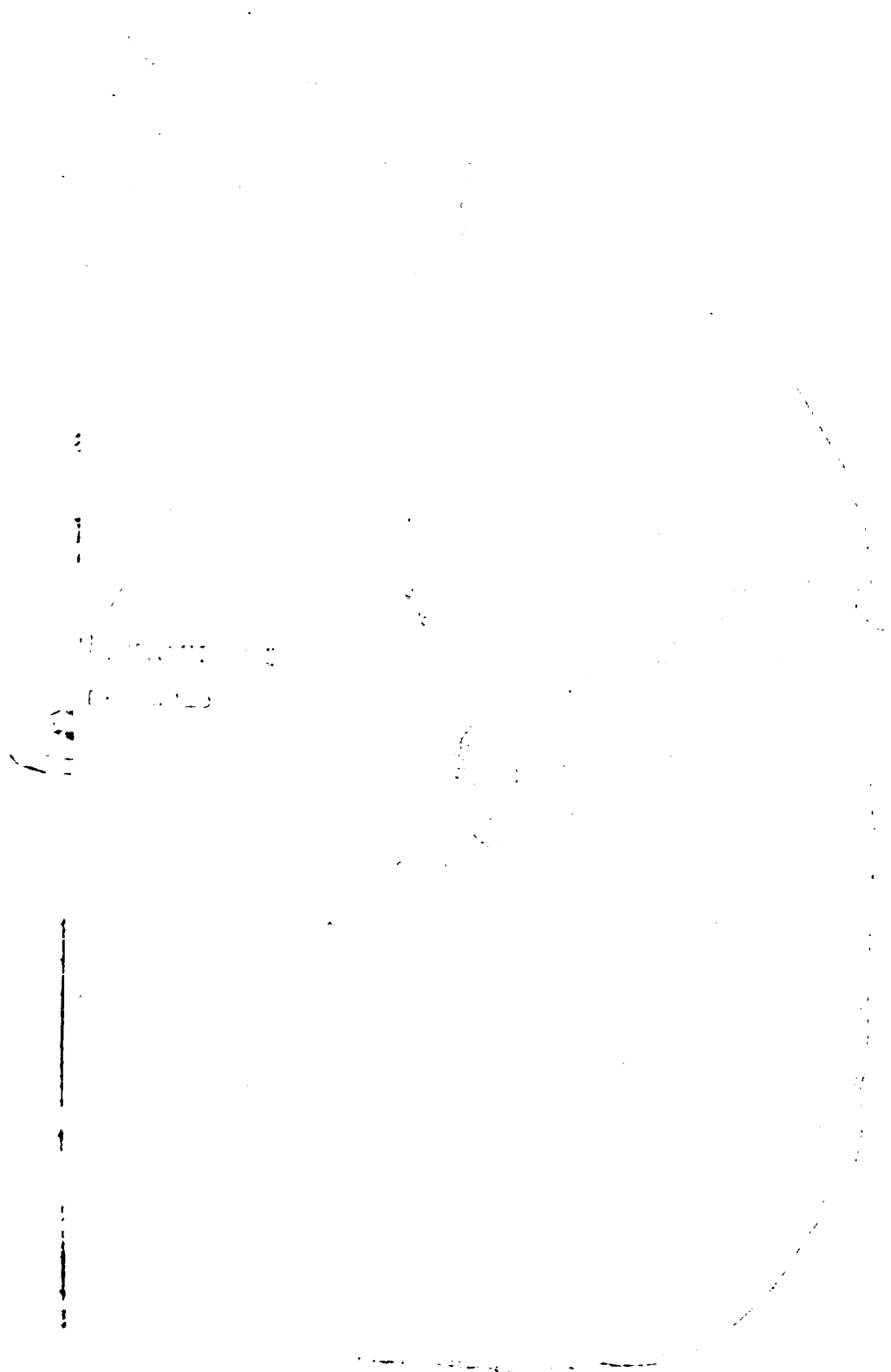

SECTION

FIG. 1

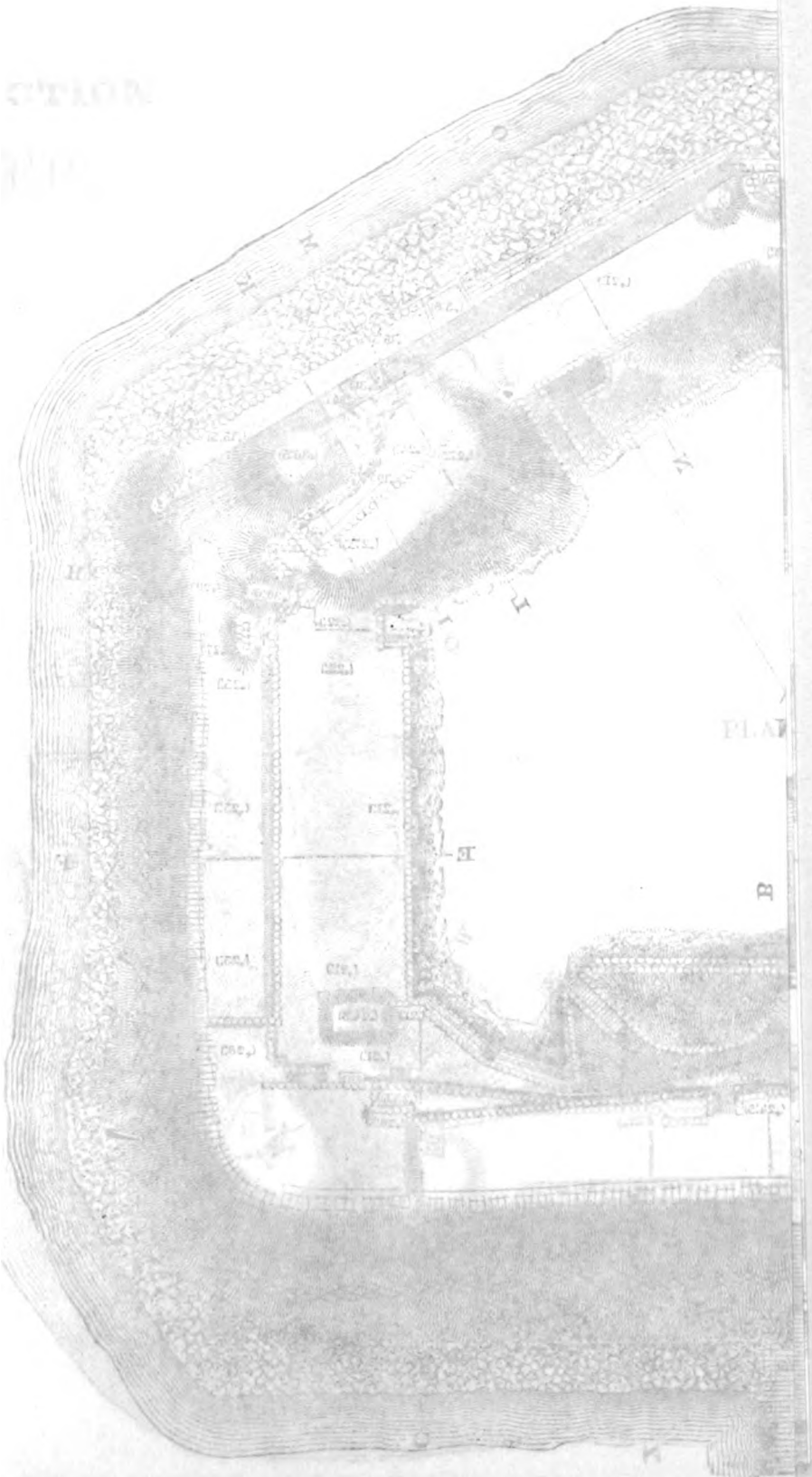

PLAN

B





5031 1900 15 1

1881



## INDEX.

- ADGER, Capt. J. E., *Ap.* cxx.
- Alston, Lt. J. J., 87; *Ap.* liii, xcix.
- Ammen, Com. D., 45, 60; *Ap.* xxiv.
- Anderson, Maj. R., 16, 23, 211; *Ap.* i, cxxxviii.
- Armored vessels, 9, 40, 43, 54, 55, 59, 171, 212, 261; *Ap.* cxliv.
- Artillery, First regt. S. C., 37, 38, 146, 191, 208, 216, 219, 221; *Ap.* liii, liv, lv.
- Ashepoo River, 35, 210; *Ap.* xvii.
- Ashley River, 16, 32; *Ap.* clxxii.
- Augusta Powder-works, 60, 61, 261, 269.
- BACHMAN, Capt. W. K., 239.
- Balch, Com. G. B., 96, 251; *Ap.* lxxxix, clii.
- Barnwell, Capt. R. H., 106; *Ap.* lxxxv.
- Basinger, Maj. W. S., *Introd.* 92, 94; *Ap.* lxxiii, lxxxvii.
- Beaufort, town of, 25, 26.
- Beauregard, Gen. G. T., assumes command at Charleston, *Ap.* i; receives surrender of Maj. Anderson in Fort Sumter, *Ap.* i; goes to Virginia, May, 1861; resumes command of Dept. S. C., Ga., and Fla., *Ap.* iv; strengthens Battery Wagner, 22; favors use of torpedoes, 30, 31; his staff, 35; hears of enemy on Folly Island, 45; directs recovery of Keokuk's guns, 65; plan of torpedo-attack, 74; opinion of naval attack on Sumter, 77; plan of using compressed moss, 79; remonstrates against reduction, 85; reinforced at Charleston, 97; orders work to be done in Sumter, 109, 110; visits Fort Sumter, 128; compliments garrison of, 146; directs evacuation of Morris Island, 151; his strategy, 153, 154; decides to hold Fort Sumter with infantry, 155; compliments Maj. Elliott on his repulse of the boat-assault, 167; commends telegraph-operator at Fort Sumter, 192; commends flag-raisers at Fort Sumter, 179, 180; visits the fort after explosion and fire, 194; transferred to the front of Petersburg, Va., 206; receives thanks of Confederate Congress for defense of Charleston, 207; new lines on James Island, 215; directs evacuation of Savannah, 240; then of Charleston, 246, 252, 270; *Ap.* D, *Ap.* E; *Ap.* liii, lxiii, cxxii; remarks on Confederate iron-clad rams, *Ap.* cxliv.
- Beauregard, Battery, 38, 49, 247; *Ap.* lx.
- Bee, Battery, 20, 49, 60, 71, 210; *Ap.* lx.
- Bee, Lt. John S., 87, 90; *Ap.* liii.
- Benham, B.-Gen. H. W., 25.
- Bennett, Mr. T. J., 112.
- Birney, B.-Gen. W., 210, 215, 220.
- Blake, Maj. J. A., 147; *Ap.* cviii, cxxxvii.
- Blanding, Maj. O., 38, 47, 128, 220; *Ap.* cii, civ.
- Blockade, 42, 72, 84; *Ap.* i.

- Blockading-squadron attacked, 28, 45.  
 Blum, Lt. R. A., 149.  
 Boag, Lt. T. G., 87, 94.  
 Boom, 29, 60.  
 Bowen, Lt. R. J., 156.  
 Boylston, Adj. S. C., 50, 64, 68, 131; *Ap.* liv.  
 Bradford, Lt. C. H., 163.  
 Breaching-batteries, 118, 119, 153.  
 Brooke, Lt. J. M., 41.  
 Brooks, Maj. T. B., 99; *Ap.* cv.  
 Brown, Lt.-Col. J. W., 248.  
 Brown, Lt. A. P., 185.  
 Bryan, Maj. H., 151; *Ap.* xevi.  
 Bryan, Capt. E. P., 35, 73.  
 Bull's Bay, 200, 247, 249, 250, 251, 252.  
 Burnet, Capt. B. S., 159; *Ap.* cxxix, cxxxiii.  
 "Burnet's," battery at, 247; *Ap.* xx.  
 Butler, Col. W., 36, 157, 158, 229; *Ap.* liii, cxxxiv.
- CADETS S. C. Mil. Academy, 218, 239; *Ap.* i, exliiii.  
 Calcium light, 150, 175, 176; *Ap.* cvi.  
 Campbell, Lt. James, 105; *Ap.* lxxxix.  
 Capers, Lt.-Col. E., *Ap.* iii.  
 Carlin, Capt. J., *Ap.* xxix, xciv.  
 Carson, Capt. J. M., 179, 201.  
 Castle Pinckney, 21, 32, 37.  
 Cathcart, W. R., 192; *Ap.* cxlvii.  
 Catskill, monitor, 45, 50, 122.  
 Champneys, Capt. J. T., 144, 147, 182; *Ap.* cxxxix.  
 Chapman, Lt. W. H., 26, 249.  
 Charles's battery, 200, 221; *Ap.* clvi.  
 Charleston, iron-clad, 34; *Ap.* xvi.  
 Charleston, city of, 16, 40; capture planned, *Ap.* 1; forces around, reduced, 85; fire upon, opened and continued, 128, 129, 132, 178, 215, 236, 239, 242, 245, 252; cannon rifled, 261; martial law declared, *Ap.* ii; suspended, iv; damage under fire, xcvi.  
 Charleston battalion, 102, 180, 198, 200, 221; *Ap.* lxxxv, lxxxviii, cxxxvii.  
 Charleston and Savannah R. R., 24, 26, 214.  
 Chatfield, Col. J. L., 90; *Ap.* lxxx.  
 Chichester, Capt. C. E., 87, 144; *Ap.* lxxiii, lxxxviii, c.  
 Claiborne, Lt. C. H., 212; *Ap.* xvii.  
 Clark, Capt. T. H., 221; *Ap.* clvi.  
 Clingman, B.-Gen. T. L., 36.  
 Colcock, Col. C. J., 26, 237, 238.  
 Colecock, Lt. W. F., Jr., *Ap.* lv.  
 Cole's Island, 21, 25, 41; disarmed, *Ap.* iii.  
 Colhoun, Com. E. R., 157; *Ap.* cxxvii.  
 Colquitt's brigade, 138; *Ap.* exliiii.  
 Columbia, iron-clad, 33, 34, 261.  
 Combahee River, 240, 247.  
 Cook, George S., photographer, 166.  
 Coosawhatchie, 237, 239, 240.  
 Cumming's Point, 16, 49, 73, 103, 149, 160, 175, 197, 267; *Ap.* lxii.
- DAHLGREN, R.-Admiral J. A., 86, 91, 102, 134, 140, 156, 159, 160, 209, 211, 222, 223, 228, 232, 236, 242, 246, 247, 250, 267; *Ap.* ch. vi., *Ap.* E.  
 Dai-Ching, gunboat, 247; *Ap.* xx.  
 Dantzler, Lt.-Col. O. M., 151; *Ap.* lxi.  
 David, torpedo-boat, 31; *Ap.* xiii, xxx.  
 Davidson, Lt. H., 30.  
 Davis, B.-Gen. W. W. H., 84, 159, 168, 170, 174, 199, 261.  
 DeLisle, C. G., 32; *Ap.* xix.  
 DeLorme, Lt. T. M., 215.  
 DeSaussure, Lt. D. B., 158; *Ap.* cxxxiv.  
 Devereux, Sergt. N. F., 212.  
 Dibble, Lt. S., *Ap.* vi.  
 Dixon, Lt. G. E., 200; *Ap.* xvi.  
 Downes, Com. J., 45, 53.  
 Dozier, Lt. W. G., 216, 219, 221, 223.  
 Drayton, B.-Gen. T. F., 24; *Ap.* ii.  
 Drayton, Capt. P., 45, 46, 52, 60.

- Dupont, R.-Ad. S. F., 24, 41, 43, 45, 55, 71, 86, 223, 265; *Ap.* 1, li, lv, lxx, lxxvi.
- EASON, J. M., 92, 261.
- Echols, Maj. W. H., 35, 49, 78; *Ap.* lvii.
- Edgerton, Lt. E. C., *Ap.* cxxix, cxlvi.
- Edisto, 44, 75, 88, 97, 215, 220, 247.
- Edwards, Lt.-Col. A. C., 238, 239; *Ap.* clvii.
- Elliott, Maj. S., 147, 155, 156, 161, 165, 168, 169, 172, 174, 190, 198, 206; *Ap.* cviii, cxxxvii, cxlv, cxlvii.
- Erwin, Lt. E. A., *Ap.* cxi, cxxxiii.
- Evening gun (Sumter), 204, 205.
- FEILDEN, Capt. H. W., *Introd.* 3, 5.
- Fickling, Lt. E. S., 131; *Ap.* xxx, liii, xciv.
- Fisher, Fort, 236, 274.
- Flag-raising (Fort Sumter), 123, 131, 178, 179, 180, 199, 212, 213, 214.
- Flag-raising (Battery Wagner), 106; *Ap.* lxxxv.
- Fleming, Capt. D. G., 131, 138; *Ap.* liii.
- Folly Island, 16, 41, 44, 83, 87.
- Foster, Maj.-Gen. J. G., 41, 211, 219, 222, 224, 226, 228, 232, 233, 234, 247, 248.
- Frost, Capt. E. D., 189; *Ap.* cxlviii.
- Frost, Lt. H. W., 87.
- GAILLARD, Lt.-Col. P. C., 37, 101, 103, 131, 147; *Ap.* lxxxv, lxxxviii.
- Gaillard, Capt. A. S., 191, 219.
- Gardner, Maj. J., 150; *Ap.* cxviii, cxxvii.
- Gilchrist, Lt. R. C., 87, 95, 152.
- Gillmore, Maj.-Gen. Q. A., 86, 97, 103, 104, 134, 148, 150, 151, 153, 160, 170, 199, 209, 248, 250, 265, 266; *Ap.* xc-xciv, cxl.
- Gilmer, Maj.-Gen. J., 137; *Ap.* cii, civ.
- Gist, B.-Gen. S. R., 36.
- Glassell, Lt. W. T., 31, 34, 74, 75; *Ap.* xxx, xxxi.
- Graham, Col. R. F., 37, 87, 90, 100; *Ap.* lxxi.
- Gregg, Battery, 22, 49, 81, 122, 149, 153; *Ap.* cxxvii.
- Gregorie, Capt. J. W., engineer at Wagner, 148.
- Gregorie's Point, skirmish at, 239.
- Grimball, Lt. W. H., 130; *Ap.* liii.
- Grimball's Causeway, action at, 248, 249.
- HAGOOD, B.-Gen. J., 25, 35, 75, 106; *Ap.* lxxviii.
- Haines, Capt. J. R., 149.
- Hall, Lt. F. M., 147, 184.
- Hardee, Lt.-Gen., 240, 244, 245, 249, 252.
- Harleston, Capt. F. H., 128, 137, 177, 178; *Ap.* liii, cii.
- Harris, Col. D. B., 35, 39, 64, 78, 103, 121, 131, 137, 151, 182, 194, 206, 270; *Ap.* D; *Ap.* lxxiv, lxxxvi, cii, civ, cx.
- Harrison, Col. G. P., 222, 256; *Ap.* cxlii, clvii.
- Hartwell, Col. A. S., 249.
- Haskell, Capt. C. T., 88, 90, 91; *Ap.* v, vi.
- Hatch, B.-Gen. J. P., 209, 215, 221, 237.
- Hatch, Col. L. M., 25; *Ap.* clxvii.
- Hayne, Capt. T. B., 221; *Ap.* cliv.
- Heine, Col. W., 215.
- Heyward, Lt. J. G., 87, 90.
- Honey Hill, action of, 237, 238.
- Hopkins, Capt. J. W., 147, 161; *Ap.* cxxxvii.
- Housatonic, sloop-of-war, 45, 200; *Ap.* lxxvi, cxlix.
- Houston, Lt. J. H., 173, 178, 204.
- Hoyt, Col. H. M., 216, 218, 219.
- Huger, Maj. C. K., *Ap.* lxi.
- Huger, F. K., 144, 161.
- Huguenin, Capt. T. A., 151, 229, 232,







SECTION

of the

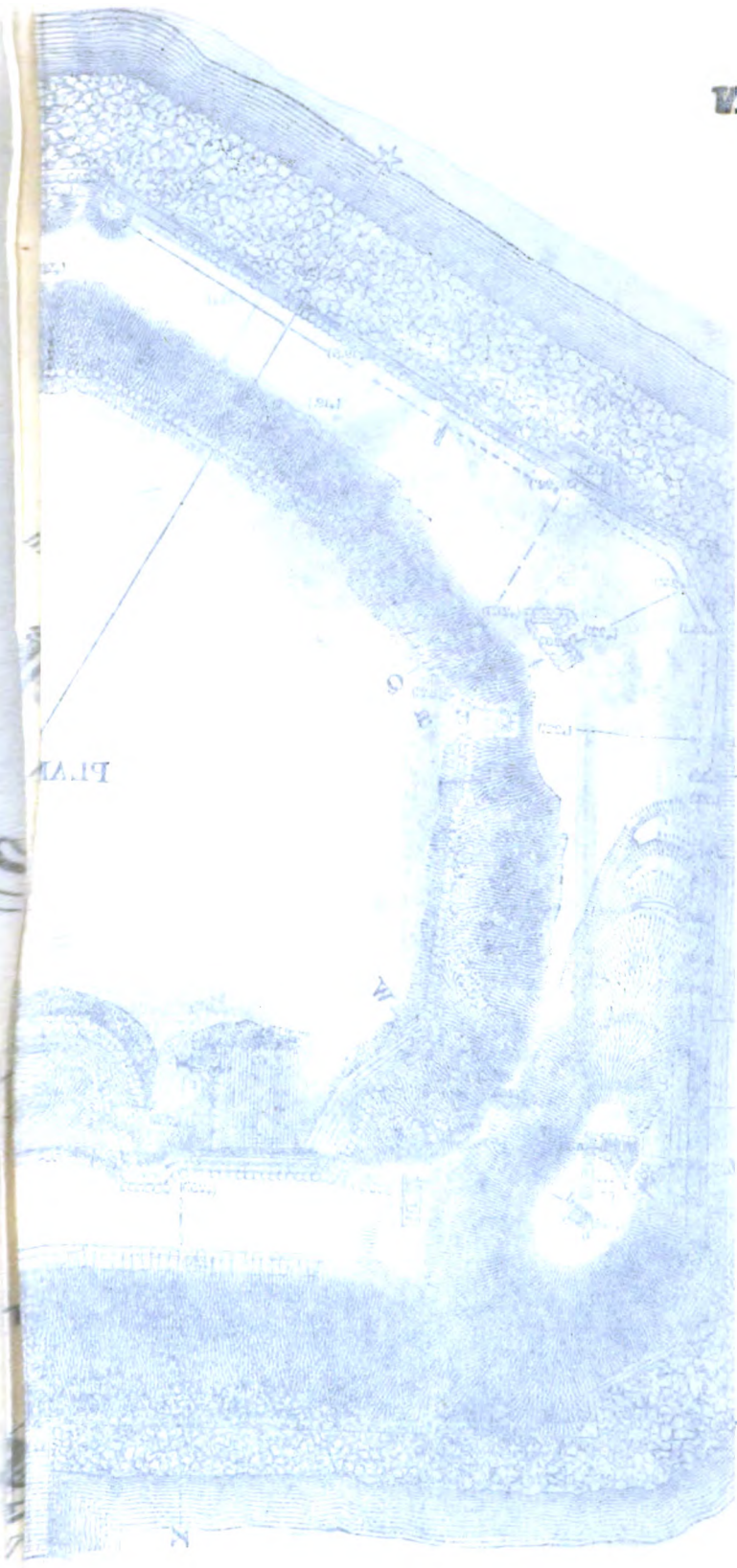

PLANT

1111

1111

1111

1111

- 254, 257, 259; "Journal at Battery Wagner," *Ap.* cx, cxliii.  
 Hunter, Maj.-Gen. D., 25, 41, 45, 86.
- INGLESBY, Lt. C., 51; *Ap.* liv.  
 Ingraham, Flag-officer D. N., 28, 34.  
 Inundation, line of, *Ap.* clxvii.  
 Ironsides, New, 42, 43, 49, 54; *Ap.* B; *Ap.* cxxx.
- JAMES ISLAND, 16, 21, 25, 38, 86, 87, 96, 104, 108, 150, 162, 216, 219, 220, 226, 248, 249, 259; *Ap.* cliii.  
 Jenkins, Maj. John, 200, 220, 222, 239; *Ap.* clvi.  
 John's Island, 16, 198, 199, 200, 215, 219, 220, 222; *Ap.* clvi.  
 Johnson, Capt. Joseph, 23.  
 Johnson, Lt. (Capt.) John, 109, 121, 128, 137, 147, 182, 187, 190, 225, 231; *Ap.* cii, cxlviii, clviii, clxxi.  
 Johnson, Fort, 21, 29, 211, 215, 216, 217, 218, 222, 223, 232, 267; *Ap.* xvii, cliii.  
 Jones, Maj.-Gen. S., 206, 219, 223, 239; *Ap.* cliii.  
 Jones, Lt. Iredell, 130, 140; *Ap.* liii.  
 Jordan, B.-Gen. T., 35, 39, 110, 146.  
 Juno, Confederate gunboat, 114.
- KANAPAUX's light battery, 237, 239.  
 Keitt, Col. L. M., 36, 149, 150, 151; *Ap.* lx, cxvi.  
 Kemper, Lt.-Col. Del, 97, 222.  
 Kemper, Lt. K., 66, 71; *Ap.* liii.  
 Keokuk, iron-clad, 43, 45, 52, 53, 54, 60, 62, 67, 80, 261.  
 Key, Lt. J. R., *Introd.* 187.  
 King's Creek, skirmish at, 220.  
 King, Capt. J. G., *Ap.* liii.  
 King, Adj. M., *Ap.* lxi, cxxx.
- LACOSTE, A. W., 65, 67, 69, 71; *Ap.* liv.  
 Lamar, Col. T. G., 25.  
 Lamar, Fort (Battery), 21, 25, 27.  
 Lee, Maj.-Gen. R. E., 39; *Ap.* i, ii.  
 Lee, Capt. F. D., 22, 30, 31, 74; *Ap.* lxiv, cxlv, clix.  
 Legaré's, S., skirmish at, *Ap.* iii.  
 Legaréville, *Ap.* cl.  
 Lehigh, monitor, 158, 179, 228; *Ap.* cxlvi.  
 Lesesne, Capt. H. R., 87, 149; *Ap.* cxxvii.  
 Little, Maj. E. H., 216.  
 Long Island, 17, 170.  
 Lord, Capt. S., 147, 161; *Ap.* cxxxvii.  
 Lowndes, Lt. Edward, 218.  
 Lowndes, T. Pinckney, 73, 74; *Ap.* liv.  
 Lucas, Maj. J. J., 36, 220; *Ap.* cliv.
- MACBETH, Capt. J. R., 87, 90; *Ap.* liii.  
 Macbeth, Lt. E. W., 150.  
 Magazines, 18, 51, 103, 188, 189, 190, 191, 194, 225, 263; *Ap.* cxlvii.  
 Manigault, Maj. E., 215, 248, 249; *Ap.* liv.  
 Marblehead, gunboat, 96, 198; *Ap.* cl.  
 Marsh Battery, 128, 132.  
 Marshall, Battery, 21; *Ap.* xix.  
 Mathewes, J. Fraser, 113, 139; *Ap.* cxxi.  
 Mathewes, Capt. J. R., 87, 94, 140; *Ap.* lxii.  
 Mazyek, Lt. E., *Ap.* cxvii, cxix, cxxiv, cxxvi.  
 McAllister, Fort, 42, 272.  
 Melver, Maj. G. W., 87; *Ap.* lxxi.  
 McLaws, Maj.-Gen. L., 240, 252.  
 McNelty, Capt. W. T., 68, 184.  
 Meade, Lt.-Com. R. W., *Ap.* cli.  
 Middleton, H. B., 199; *Ap.* xv.  
 Middleton, Williams, 111, 112.  
 Miles, Capt. F. T., 147, 156, 161, 198; *Ap.* c.  
 Mills, Lt. T. S., 23.  
 Mitchel, Capt. John C., 83, 87, 90, 94, 206, 208, 209, 223, 225, 226, 227, 228; *Ap.* liii, clviii.  
 Montauk, monitor, 43, 45, 102, 141, 158.

- Morris Island**, 16, 22, 38, 68, 77, 81, 84, 85, 87, 88; descent on, 90, 98, 101, 118, 119, 120, 127, 135, 151, 168, 209, 223, 227, 235, 266, 269; strategic value of, *Ap. E.*
- Moultrie, Fort**, 20, 23, 29, 38, 44, 46, 48, 59, 102, 130, 140; attacked by fleet, 157-159, 178, 229; *Ap. Ix, cxlvi.* (For plan of, see plates after Appendix.)
- Mulvaney, Capt. J. M.**, 147, 161; *Ap. cxxxvii.*
- Murrell's Inlet**, *Ap. xiii, xv.*
- NAHANT**, monitor, 45, 52, 60, 129, 158.
- Nance, Capt. W. F.**, *Ap. lii, lxi, lxxiii, lxxxviii, clviii.*
- Nantucket**, monitor, 45, 50, 52.
- Naval brigade, Confederate**, 219, 220.
- Naval brigade, Union**, 236, 237.
- Nelson's battalion**, 91, 100; *Ap. lxxii, lxxiii.*
- New Ironsides**, frigate, 43, 44, 45, 49, 54, 56, 72, 102, 125, 127, 129, 130, 149, 157, 158, 211; *Ap. B, lxxvii.*
- OBSTRUCTIONS**, harbor, 29, 30, 60, 77, 173, 178, 225, 262; *Ap. lxii, lxiii, lxxv, clxxi.*
- Odenheimer, Lt. W. H.**, 151; *Ap. cxv.*
- Ogier, Lt. W. G.**, 221, 257; *Ap. cliv.*
- Olmstead, Col. C. H.**, 92, 94, 95; *Ap. lxxiii, lxxxvii, cxliii.*
- Opposing land-forces**, *Ap. cxl, clxxvi.*
- Oyster Point (Morris Island)**, 84.
- PALMER**, Maj. F. G., *Ap. ii.*
- Palmetto State**, Confederate gunboat, 28, 32, 34, 48, 140, 261; *Ap. cxliv.*
- Parker, Lt. W. H.**, 74, 75.
- Parker, Capt. E. L.**, 97, 200, 220, 221, 251, 252; *Ap. xx, clvi.*
- Passaic**, monitor, 43, 45, 46, 48, 51, 52, 129, 141, 158.
- Patapsco**, monitor, 43, 45, 51, 112, 129, 141, 158, 179, 246; *Ap. clxiv.*
- Pawnee**, sloop-of-war, 96, 198, 247; *Ap. lxvi.*
- Payne, Capt. L. S.**, 113.
- Payne's Dock**, *Ap. clv.*
- Pemberton, Fort**, 21, 29, 215. (See map of defenses.)
- Pemberton, Maj.-Gen. J. C.**, 22, 82; *Ap. ii, iv.*
- Peronneau, Capt. W. H.**, 64; *Ap. liii.*
- Pinckney, Capt. C. C., Jr.**, *Ap. cx xv.*
- Pinckney, Castle**, 21, 32, 37.
- Planter**, steamer, abduction of, *Ap. iii.*
- Pocotaligo**, 25, 26; *Ap. iii, iv.*
- Porcher, Lt. Phil.**, 114; *Ap. ix.*
- Port Royal**, 24, 41, 237, 268, 271.
- Porter, Lt. B. H.**, 163.
- Potter, B.-Gen. E. E.**, 250, 252.
- Powder-raft**, 232, 233, 234.
- Powder-works**, 60, 61, 261.
- Powe, Lt. J. H.**, *Ap. lxxxvii.*
- Powhatan**, sloop-of-war, *Ap. clx.*
- Preble, Com. G. H.**, 237.
- Pressley, Lt.-Col. J. G.**, 151; *Ap. cxvii, cxxiv.*
- Preston, Lt. S. W.**, 160, 163.
- Pringle, Battery (Fort)**, 215, 220, 221; *Ap. cliii.*
- Pringle, Capt. R.**, 129; *Ap. xcix, c.*
- Pringle, Maj. M. A.**, 184; *Ap. cxix.*
- Pulaski, Fort**, 271.
- Putnam, Col. H. S.**, 104, 105.
- RAINS**, B.-Gen. G. J., 30.
- Rains, Col. Geo. W.**, 61, 269.
- Ramsay, Maj. D.**, 103, 106, 107; *Ap. lxxxv, lxxxviii.*
- Ravenel, Capt. S. P.**, *Ap. liv.*
- Ravenel, St. J.**, *Ap. xxx, clxiv.*
- Ravenel, Surg. W. C.**, *Ap. cxx.*
- Reddick, Lt. W. E.**, 106; *Ap. lxxxv.*
- Remey, Lt. G. C.**, 162, 163.
- Rhett, Col. A.**, 37, 47, 64, 73, 121, 128, 131, 142; *Ap. lii, lxiii, cii, civ.*
- Rhett, Lt. J. M.**, 66, 68, 121, 139, 221; *Ap. liii, cliv.*
- Rhind, Com. A. C.**, 45, 53; *Ap. lv.*

- Rion, Maj. J. H., 91, 93, 100, 101; *Ap.* lxxvii, lxxxiii.
- Ripley, B.-Gen. R. S., repairs Fort Sumter, 18; commands First Mil. District, 35, 36, 64, 73, 81, 82, 83, 86, 120, 124, 128, 169; change of command in harbor, 172, 207, 270; *Ap.* lxii, lxxv; his paper on defenses of Charleston, *Ap.* clxv.
- Ripley, Fort, 21, 29, 37, 93.
- Rivers's Causeway, skirmish at, 215; *Ap.* xvii.
- Rivers's Bridge, action at, *Ap.* xx.
- Robertson, B.-Gen. B. H., 221, 239.
- Rodgers, Com. G. W., 122.
- Rodgers, Fleet-Capt. C. R. P., 54.
- Rodgers, Capt. John, 45, 46, 63, 242; *Ap.* clii.
- Rodman, Lt.-Col. D. C., 90, 94, 95; *Ap.* lxix, lxx.
- Rowan, Capt. S. C., 158; *Ap.* xxviii, xxxiii.
- Rutledge, Lt.-Com. J., 28, 34, 68.
- Ryan, Capt. W. H., 106, 107.
- SAVANNAH, 240, 243; *Ap.* ii, xix, xx.
- Schimmelfennig, B.-Gen. A., 209, 216, 249; *Ap.* xvii.
- Schulz's battery, 97.
- Secessionville, 21, 25; *Ap.* iii, iv, clxvii.
- Sellers, Capt. M. H., 113, 192.
- Sewee Bay, 250, 251.
- Seymour, B.-Gen. T., 88, 104, 105; *Ap.* lxxix.
- Shaw, Col. R., 104, 106; *Ap.* lxxx, lxxxii.
- Sherman, Maj.-Gen. W. T., 236, 240, 242, 245, 247, 250, 254.
- Signals intercepted, 72, 74.
- Simkins Battery, 214, 216, 217, 222; *Ap.* cv, cxxxiii.
- Simkins, Lt.-Col. J. C., 101, 107; *Ap.* lx.
- Simons, Capt. T. Y., 147, 161.
- Simonton, Col. C. H., 36, 96.
- Smith, Maj.-Gen. G. W., 78, 237.
- Smith, B.-Gen. W. D., *Ap.* iii.
- Smith, Capt. R. P., 159; *Ap.* cxxviii.
- Smith, Adj. W. M., *Ap.* cix, cxxxviii.
- Smith, Isaac, gunboat, 26, 28.
- South Carolina, State of, 35, 46, 77, 236, 240, 242, 245, 254, 260.
- Stanly, Com. F., 250, 251.
- Stevens, Com. T. H., 160, 162; *Ap.* cxxxv, cxxxvi.
- Stevens, Maj. P. F., *Ap.* i, ii.
- Stevens, Col. C. H., *Ap.* xxxvi.
- Stone fleet, *Ap.* ii.
- Stoney, T. D., *Ap.* xxx, clxix.
- Stoney, Capt. W. E., *Ap.* lxxii, lxxxvii.
- Stono Inlet, 16, 22, 41, 44, 86.
- Stono River, 21, 26, 29, 86, 88.
- Strong, B.-Gen. G. C., 87, 93, 104; *Ap.* lxxviii, lxx, lxxi, lxxx, cxi.
- Stuart, Capt. H. M., 239.
- Stuart, Lt. H. M., 140, 221.
- Sullivan's Island, situation, 16; armament, 38, 72; fortifications, 77, 87, 104; naval attack, 158, 159, 162, 175, 210, 219, 226, 229, 247, 250, 259; *Ap.* cxxviii, cxxx, cxxxiii.
- Sumter, Fort, plan, site, and construction, 17, 18, 19; taken by Confederates, 23; armament and garrison, 38; engages the iron-clad squadron, 44-53; damages, 56, 57, 59; mounts one of the Keokuk's guns, 71; preparations, 78-80; opens on Morris Island in protection of Wagner, 92-108; armament reduced, 108, 109; gorge-rooms filled, 109, 110; new wharf constructed, 111; preliminary firing from Morris Island, 115; the first great bombardment begins, 119; stability of the gorge demonstrated, 125; first breach in north wall, 126; Gen. Gillmore demands surrender, 128; night-attack by squadron, 129; fires last gun in action, 130; its demolition effected, 134; a popular mistake corrected, 134; fire slackened, 135; the 300-pounder Parrott rifle most destructive, 136; council

- of defense, 137; removal of powder, 137; severe night-attack by the iron-clad squadron, 141; the fort silenced, 142; the close of the first great bombardment, 143; Col. Rhett's artillerists withdrawn; Maj. Elliott comd'g, 147; R.-Ad. Dahlgren demands its surrender, 156; fired on by Weehawken, 157; the assault by night from small boats, 160-166; views taken in September, 166; a season of quiet, 169; mounts three heavy guns in casemate, 170; second great bombardment opens, 170; sharpshooters, 173; scouts land on the fort at night—alarms, 174, 175; calcium light, 176; interior defenses, 177; replacing the flags, 178-180; results of bombardment, 180, 181; views taken in December, 187, 188; magazine explodes and sets fire to quarters, 189-191; repairs 195; mining the long gallery, 196; a Christmas dinner, 198; Washington's birthday, 201; bell ringing for alarms, 202; palmetto shield for east battery, 203; general improvements, 204, 205; last fire upon fort by iron-clad squadron, 210; third great bombardment opens, 223, and is continued sixty days: the commander, Capt. Mitchel, mortally wounded on the fourteenth day, 228; Capt. Huguenin succeeds to command, 230; Gen. Foster's powder-rafts a failure, 232, 233; his assaulting-arks devised, 234; end of third great bombardment, 235; a period of quiet, 254; preparations for evacuation, and the order given, 256, 257, 258, 259; summary of bombardments, casualties, etc., 265, 272; *Ap.* c, cii; details of naval assault, cxxxiv, cxl, cxlvii; condition at time of evacuation, clxxxiii. (For illustration, see plans and sections at end of volume.)
- Swinton, Lt. T. L., 184, 257, 258.  
Swinton, W., historian, 61, 268.
- TALIAFERRO, B.-Gen. W. B., 73, 100, 103, 219, 220, 239; *Ap.* lxxxiii, cliii, cliv.
- Tatom, Capt. W. T., 101, 107; *Ap.* lx, lxxxiv.
- Thompson, Lt. G. W., 107.
- Torpedoes, 30, 31, 32, 148, 159, 200, 246, 262; *Ap.* clix, clxiv, clxvii, clxxi.
- Torpedo-rafts, 46, 63.
- Torpedo-ram, 31; *Ap.* lxiv, xciv.
- Trapier, B.-Gen. J. H., 30; *Ap.* lix.
- Trenholm, G. H., 31; *Ap.* clxvi.
- Tucker, Capt. J. R., 28, 34, 68, 74, 156, 223.
- Tupper, Priv. James, 180, 199.
- Turner, B.-Gen. J. W., 167.
- Tynes Battery, *Ap.* cliv. (See map of defenses of Charleston harbor.)
- VALENTINE, Capt. J., *Ap.* cxxx, cxlvi.
- Vincent's Creek, 113, 150, 160, 267.
- Voris, Col. A. C., 104, 106; *Ap.* lxxx, cxli.
- WAGNER, Battery (Fort), name, site, construction, 22, 47, 49, 81, 82, 92; first assault, 93, 94; first bombardment, 101; second assault, 104-107; opens on breaching-batteries, 121; ridge attacked, 129; carried, 147, 148; difficulties of siege increase, 148; last heavy bombardment, 149, 150; evacuated, 151; hardships of siege, 152, 153, 154, 259, 266, 269, 276; *Ap.* Chapters V., VI., VII., VIII.
- Walker (Col.), B.-Gen. W. S., 25, 26, 35; *Ap.* iii, iv.
- Walker, Capt. G. E., 20; *Ap.* clxviii.
- Walter, Capt. G. H., 97, 221.
- Wampler, Capt. J. M., 122; *Ap.* ci.
- Wappoo Cut, 21, 28, 75.
- Waring, Capt. P. H., *Ap.* lxxxvii.

- Warley, Lt. A. F., 113.  
 Washington Artillery, *Ap.* clvii.  
 Washington Light Infantry, 172, 179,  
 201.  
 Waterloo Place, John's Island, 220,  
 221.  
 Waties, Lt. T. D., 102, 219; *Ap.* cliv.  
 Wayne, Maj. R. A., 220, 221, *Ap.*  
 clvii.  
 Webb, Capt. B. C., 249.  
 Webb, Lt. W. A., 74, 75.  
 Weehawken, monitor, 43, 45, 46, 49,  
 50, 51, 55, 63, 129, 141, 157, 186;  
*Ap.* cxx, cxlvii.  
 Welles, G., Secretary U. S. N., 40, 43,  
 71; *Ap.* l, li.  
 White, Lt. E. J., 78, 124, 231, 257,  
 258; *Ap.* lviii.  
 White, Maj. J. B., 239.  
 Williams, Lt. E. P., 162, 163.  
 Wise, B.-Gen. H. A., 200; *Ap.* cl.  
 YATES, Lt.-Col. J. A., 20, 28, 47, 138,  
 216, 218, 219; *Ap.* liv, lxxiii.  
 YOUNG, Lt. W. G., 184.  
 ZEALY, Lt. C., 237.

THE END.













